

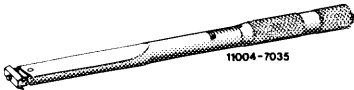





18–210 Removal and installation of oil pump

Tightening torques		Nm
Oil drain plug to oil pan		35–45
Oil pan upper half to cylinder crankcase	M 6	9–11
	M 8	20–25
Oil pan lower half to upper half		9–11
Engine carrier to engine mount front		70
Oil pump	to crankcase	20–25
	to flange member	9–11
Sprocket on oil pump		30–35
Special tools		
Torque wrench handle 20–100 Nm		001 589 35 21 00
Torque wrench handle 50–200 Nm		001 589 44 21 00
Changeover ratchet for torque wrench		001 589 42 09 00
Allen wrench 5 mm, 300 mm long		116 589 02 07 00
Knock-out mandrel 9 mm dia.		110 589 02 15 00
Socket 27 mm, 1/2" square for rotating engine		001 589 65 09 00
Knock-in tool for oil dipstick guide tube		117 589 00 31 00
Conventional tool		
Engine hoist (Motordirigent) size 1.5	e.g. made by Bäcker, D–5630 Remscheid Order No. 3178	

Note

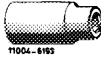
Since a connecting link might wipe against timing chain or oil pan, do not open double roller chain during repairs and connect again by means of a connecting link.

To renew double roller chain and tensioning unit, completely remove oil pan (01-310) and front cylinder housing cover (01-107).

Removal

- 1 Completely remove oil pan (01-310).
- 2 Unscrew fastening screw (56) of sprocket.
- 3 Remove torsion spring (47) from clamp (45) in rearward direction.
- 4 Turn clamp in upward direction.

45 Clamp
47 Torsion spring

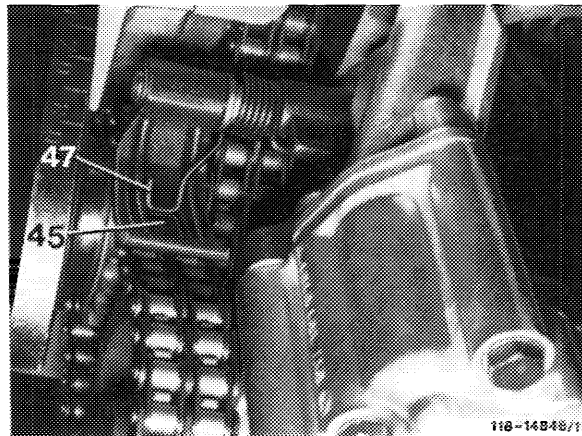

- 5 Remove sprocket by means of two screwdrivers.
- 6 Unscrew hex. screws (arrows) on oil pump and remove oil pump.
- 7 Remove sprocket.
- 8 Pull flange member (43) out of cylinder crankcase.

43 Flange member
56 Fastening screw

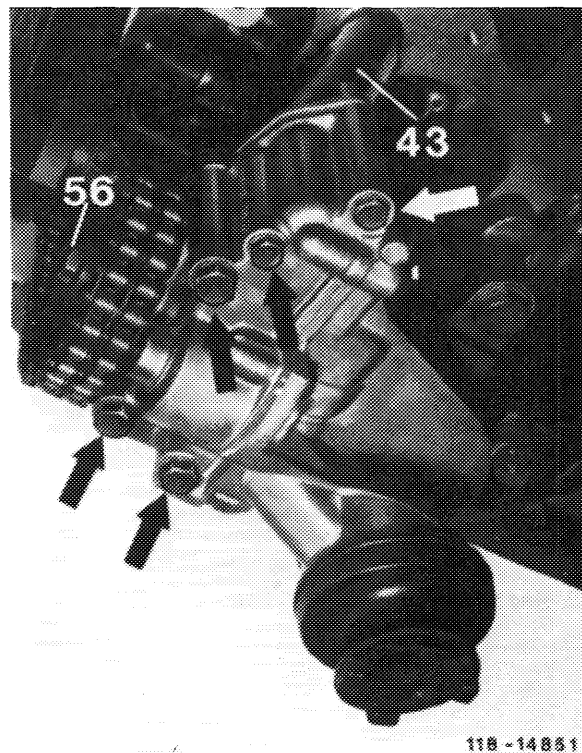

Installation

- 9 Renew O-ring (42) on flange member, if damaged.
- 10 Insert flange member.
- 11 Place sprocket into double roller chain.
- 12 Install oil pump and tighten fastening screws to 20–25 Nm on crankcase or 9–11 Nm on flange member.

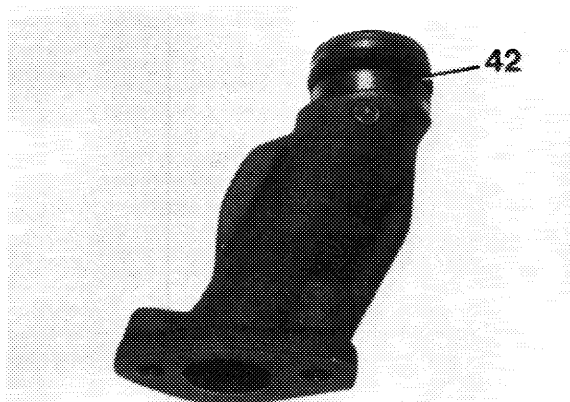

42 O-ring

118-14776

- 13 Place sprocket on drive shaft and tighten fastening screw (56) to 30–35 Nm.
- 14 Set clamp on double roller chain and place torsion spring on clamp.
- 15 Completely install oil pan (01–310).

Layout of oil pump

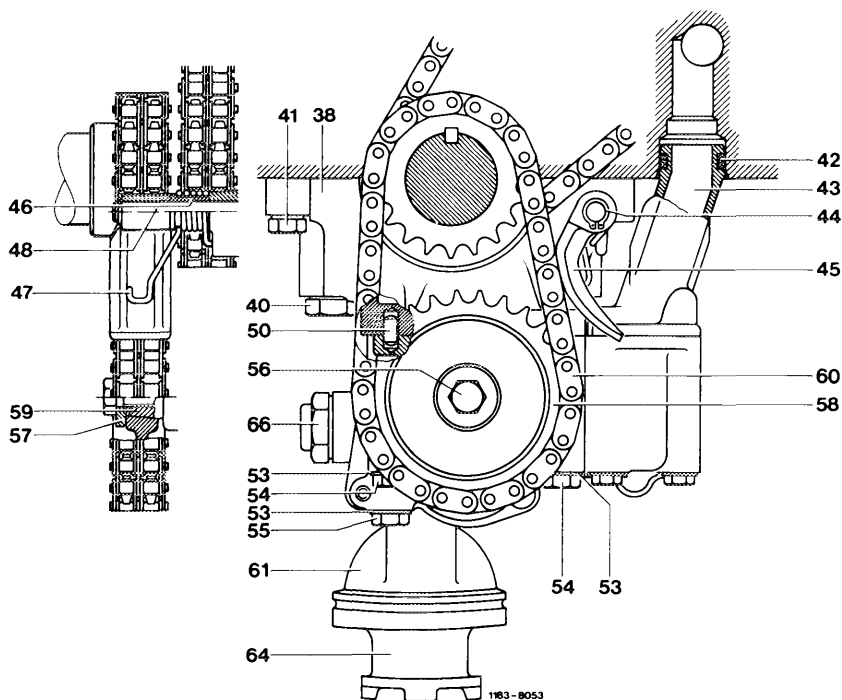

- | | | |
|-----------------------------|-------------------|---|
| 38 Crankshaft bearing cover | 47 Torsion spring | 58 Drive sprocket |
| 40 Hex. screw | 48 Bolt | 59 Drive shaft |
| 41 Hex. screw | 50 Fitted pin | 60 Double roller chain |
| 42 O-ring | 53 Spring washer | 61 Strainer |
| 43 Flange member | 54 Hex. screw | 64 Adapter |
| 44 Locking ring | 55 Hex. screw | 66 Closing plug oil pressure relief valve |
| 45 Clamp | 56 Hex. screw | |
| 46 Bushing | 57 Washer | |