

## 32–110 Removal and installation of rear shock absorber

### Upper shock absorber suspension

	Part no.	Height	OD	Rubber hardness °Shore
Rubber ring	upper	115 326 16 68	19	60 ± 5
	lower	115 326 17 68	25	
Initial tension of rubber rings	approx. 11.5 mm (limited by threads on piston rod or housing)			

### Tightening torque

Nm

Hex. screws or nuts on lower shock absorber suspension

45

Hex. nuts on upper shock absorber suspension

tighten up to end of thread

### Special tools

Hexagon ratchet wrench 17 mm

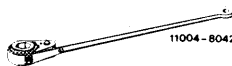

000 589 32 16 00

Retaining wrench 5 mm



116 589 04 09 00

### Note

The rear shock absorbers simultaneously serve as a deflection stop for the rear wheels. For this reason, loosen shock absorber suspension only when the vehicle rests on its wheels or when the semitrailing arm is supported.

If the shock absorber must be removed because of rumbling noises or premature leaking of piston rod seal, the alignment of the suspension points inside vehicle must be checked and if necessary corrected.

In the event of repairs and independent of make, the shock absorbers can be **individually** exchanged. Shock absorber versions identified by color code, e.g. 1 lengthwise line whiter or 1 crosswise line white, must be in agreement.

### Attention!

When removing gas pressure shock absorbers with separating piston or with piston mounted at top, with vehicle jacked up and axle half relieved, make sure that the piston rod is not turning along when loosening upper suspension. Since in this condition the resilience stop in shock absorber rests against operating piston, the attachment of operating piston to piston rod may become loose. The gas pressure would then suddenly extend piston rod and the oil in shock absorber would flow out (risk of an accident).

## Removal – Upper suspension

### Model 107.02

- 1 Remove rear seat and backrest.
- 2 Remove cover plate.

38a Cover plate for spring strut connection  
38b Cover plate for shock absorber suspension

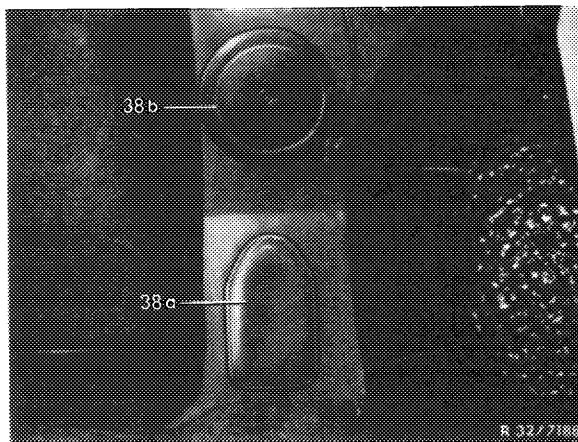

- 3 Unscrew hex. nuts on upper suspension (5) and remove rubber ring.

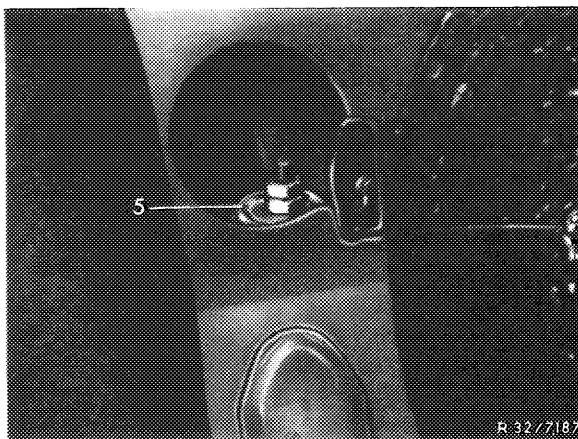

### Model 107.04

- 4 On vehicles with coupe top, remove top and open cover flap.
- 5 Remove rear seat, unscrew backrest and remove.
- 6 Remove cover flap locking lever (30) and unscrew lining (refer to arrow).

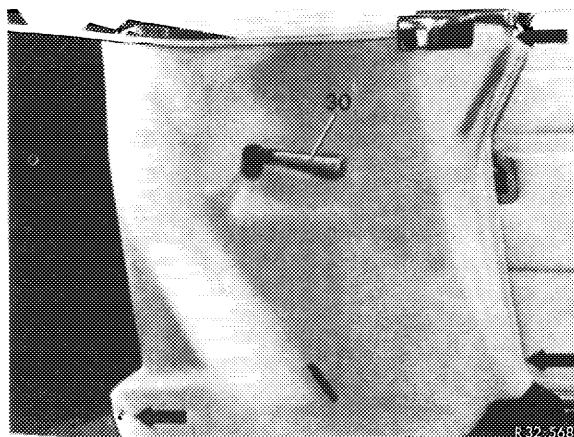

- 7 Unscrew hex. nuts on upper suspension (5) and remove rubber ring.

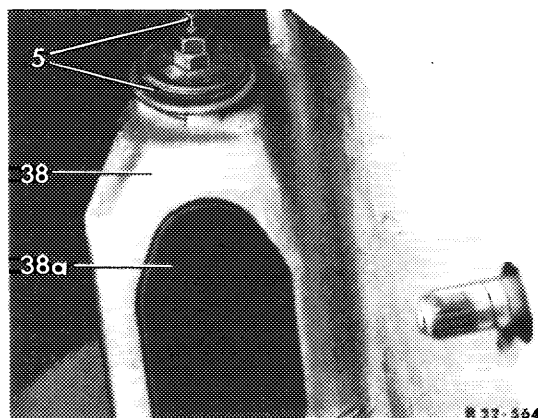

## Model 114, 115

8 Unscrew hex. nuts on upper suspension from direction of trunk, remove disk and rubber ring.

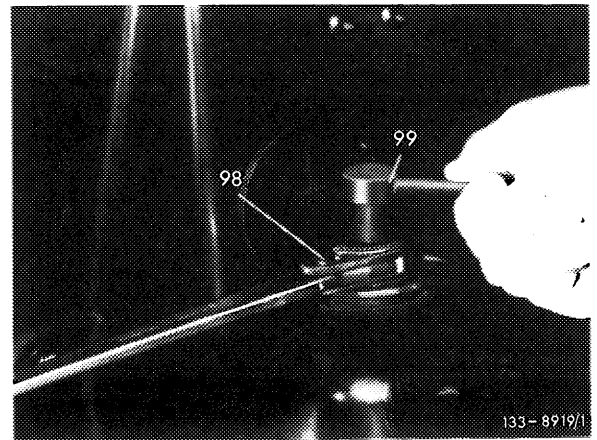
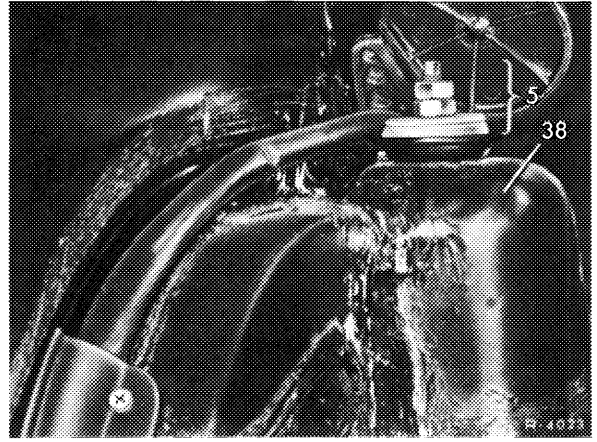

98 Hex ratchet wrench      99 Retaining wrench

## Removal — Lower suspension

9 Unscrew hex. screws or nuts (vehicles with diagonal swing axles and starting torque compensation) of lower suspension on semitrailing arm and remove shock absorber in downward direction.

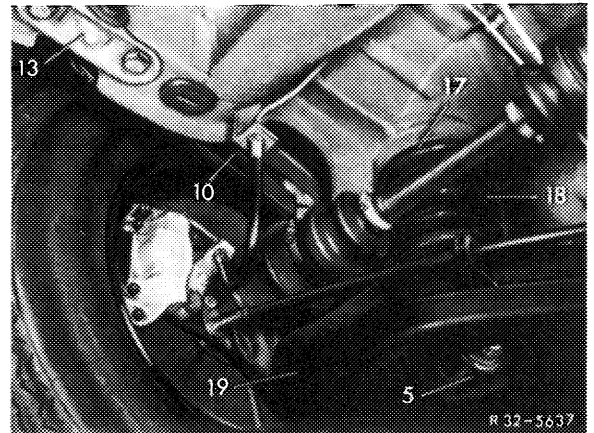

## Installation

10 Check suspension members. Fastening clip of lower shock absorber suspension should be firmly seated in rubber mount, rubber mount should not be rotatable in suspension eye.

11 Insert shock absorber and mount upper suspension, making sure that the parts are correctly seated. Tighten the lower of the two hex. nuts to end of thread, then counterlock with the upper nut.

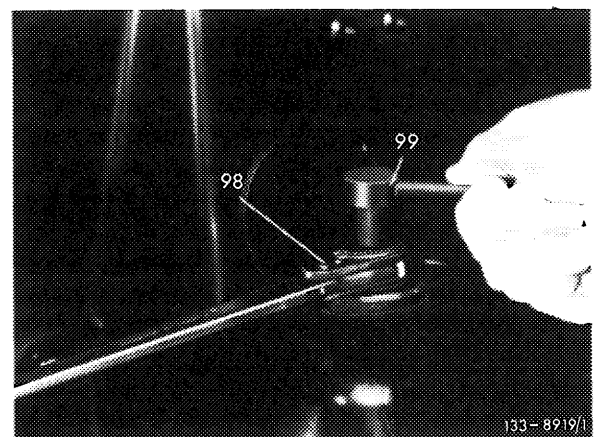

**Note:** The dust protection (5f) is installed only on vehicles for countries with poor road conditions.

Bilstein  
shock absorber  
starting November 1980 F & S

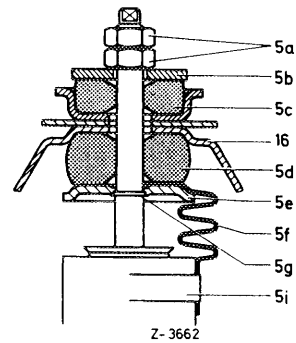

Upper suspension  
F & S shock absorber  
(version up to 1974)

- |                      |                        |
|----------------------|------------------------|
| 5a Hex nut           | 5f Dust protection     |
| 5b Washer            | 5g Locking ring        |
| 5c Upper rubber ring | 5i Clamping strap      |
| 5d Lower rubber ring | 16 Dome on frame floor |
| 5e Cup               |                        |

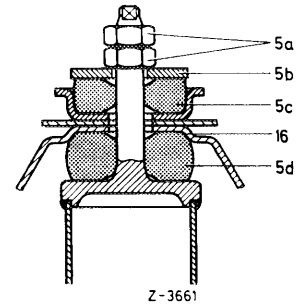

Upper suspension  
F & S  
Boge shock absorber  
(version starting 1975 up to October 1981)

- |                       |                        |
|-----------------------|------------------------|
| 75a Hex nuts          | 75e Cup                |
| 75b Washer            | 76 Dome on frame floor |
| 75c Upper rubber ring |                        |
| 75d Lower rubber ring |                        |

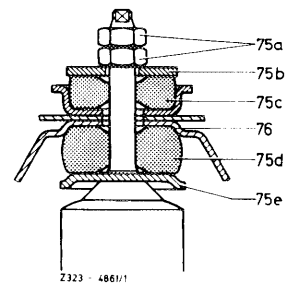

12 Mount lower suspension to semitrailing arm. If vehicle is resting on its own wheels, jack vehicle up at the rear until semitrailing arm is at level of fastening bracket on shock absorber.

13 On vehicles of 107 model series install linings, backrest and rear seat, as well as coupe top, if applicable.

**Note:** On lower shock absorber suspension, two hex bolts are screwed into semitrailing control arm of the diagonal swing axle.

On diagonal swing axle with starting torque compensation, two special bolts are inserted into the semitrailing control arm from above and retained by a pressed-on retaining disc.

If required: Renew special bolts on lower shock absorber suspension in semitrailing control arm. With shock absorber removed, knock bolts out from below using a suitable punch.

Lower suspension on diagonal swing axle

- 5f Dust protection
- 5k Suspension eye
- 5l Rubber mount
- 5m Fastening bracket
- 19 Semitrailing arm

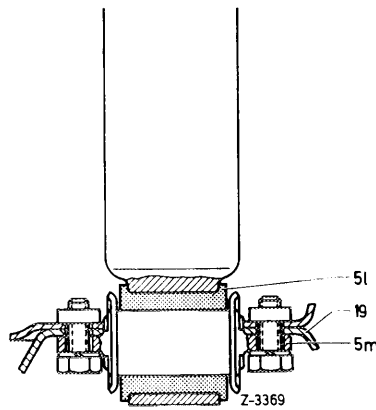

Bilstein shock absorber starting November 1980  
F & S

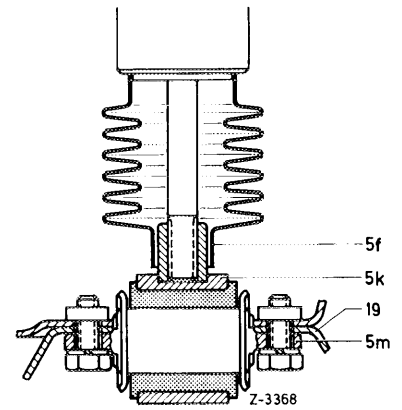

F & S shock absorber Boge shock absorber up to October 1980

Lower suspension on diagonal swing axle **with** starting torque compensation

- 5f Dust protection
- 5k Suspension eye
- 5l Rubber mount
- 5m Fastening bracket
- 19 Semitrailing control arm
- 19a Special bolt
- 19b Retaining disc

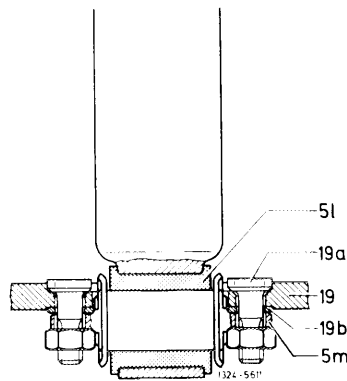

Bilstein shock absorber starting November 1980  
F & S

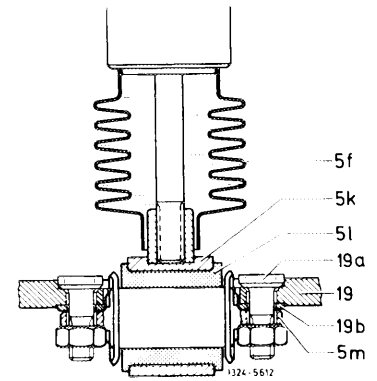

F & S shock absorber Boge shock absorber up to October 1980

After inserting new special bolts into bores in semitrailing control arm, press retaining discs on shank of special bolts. Add approx. 5 washers with an ID of 10.5 mm to the retaining disc and press the retaining disc down on to the shank of the special bolt.

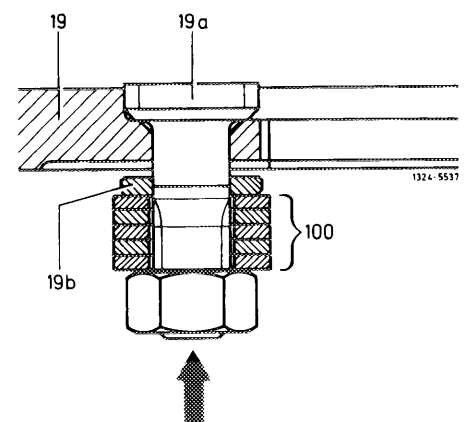

- 19 Semitrailing control arm
- 19a Special bolt
- 19b Retaining disc.
- 100 Washers ID 10.5