

33–300 Adjustment of wheel bearing end play

Data

Wheel bearing end play	0.01–0.02 mm
------------------------	--------------

Lubricant

Quantity	Into wheel cap: Grease quantity approx. 20 g (about up to edge of bead)
Series fillup: up to October 1982	Anti-friction bearing grease (refer to Specifications for service products page 265)
Series fillup: starting November 1982 and repair fillup	High-temperature anti-friction bearing grease (refer to Specifications for service products page 265.1) ¹⁾

¹⁾ Available in 150 gr. screw cans, part no. 000 989 49 51.

Tightening torque	Nm
--------------------------	----

Hex. socket screw of clamping nut	20
-----------------------------------	----

Special tools

Remover and installer for wheel cap		116 589 22 33 00
-------------------------------------	--	------------------

Holder for dial gauge to adjust wheel bearing end play		363 589 02 21 00
--	---	------------------

Conventional tool

Dial gauge A 1 DIN 878	e.g. made by Mahr, D-7300 Esslingen order No. 810
------------------------	--

Note

In the event of repairs, from now on use exclusively high-temperature anti-friction bearing grease for front wheel hubs. Generally renew complete grease charge of front wheel hub, since a mixture of anti-friction bearing grease or multi-grade grease must be absolutely prevented. If, in exceptional cases, high-temperature anti-friction bearing grease is not available, multi-grade grease (refer to Operating instructions page 267) may be used.

- 1 Jack up vehicle, remove front wheel.
- 2 Pull off wheel cap (8f) with tool (89).

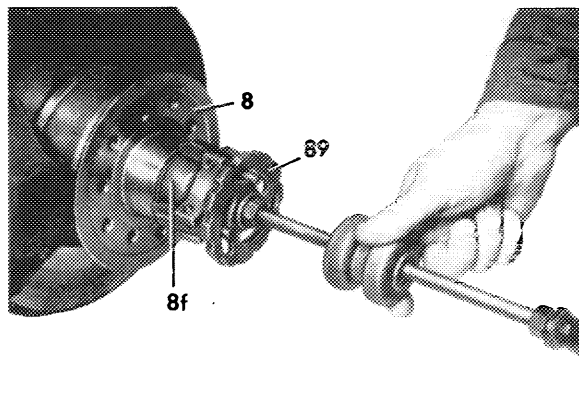

R 33-5797

- 3 Remove contact spring (arrow) for radio suppressor.
- 4 Push brake pads away from brake disc (42-160).

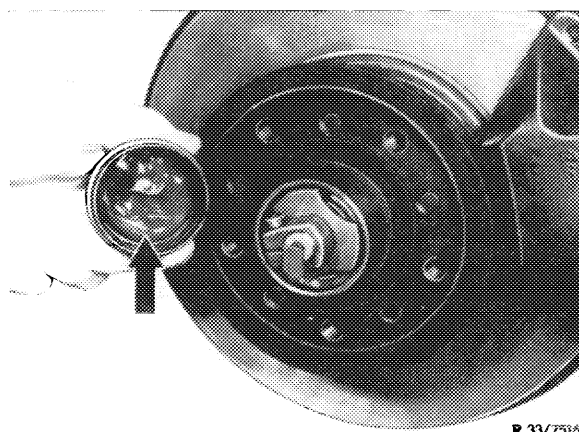

R 33/7316

- 5 Loosen hex. socket screw of clamping nut (8e), then tighten clamping nut while simultaneously rotating hub (8) so that the hub can be rotated with an effort, only. Then screw clamping nut back again for approx. 1/3 turn and loosen tension by a blow against kingpin (5a) with a plastic hammer.

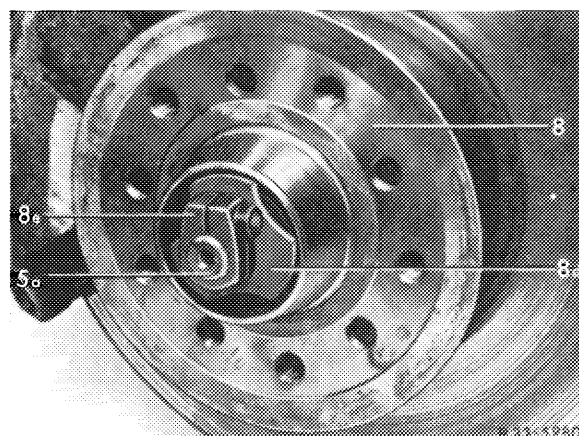

R 33-19804

- 6 Place tester (015) on front wheel hub and set dial gauge (022) to approx. 2 mm preload.

Note: For measuring wheel bearing play, the formerly valid tester (015), part no. 116 589 12 21 00 may also be used.

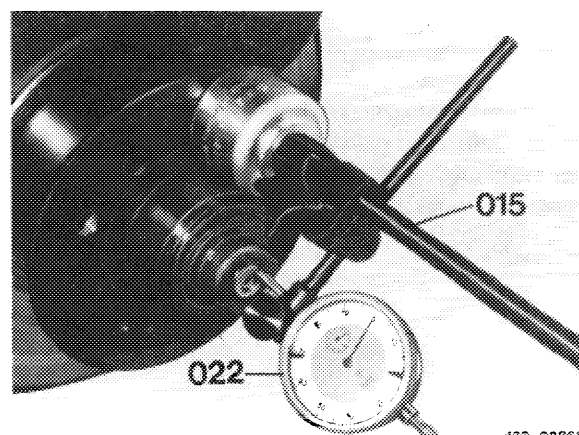

133-22860

7 Check end play of wheel hub by pulling and pushing energetically on flange.

Rotate wheel hub several times each time prior to measuring.

Attention!

Do not rotate wheel hub while measuring.

Each rotary movement of wheel hub is indicated on dial gauge, so that accurate reading of actual end play would be impossible.

Front wheel hub without ABS

- | | | | |
|----|--------------------------------|----|---------------|
| 5 | Steering knuckle | 8e | Clamping nut |
| 8 | Wheel hub | 8f | Wheel cap |
| 8a | Radial sealing ring | 9 | Brake disc |
| 8b | Tapered roller bearing inside | 17 | Brake hose |
| 8c | Tapered roller bearing outside | 18 | Fixed caliper |
| 8d | Washer | 32 | Cover plate |

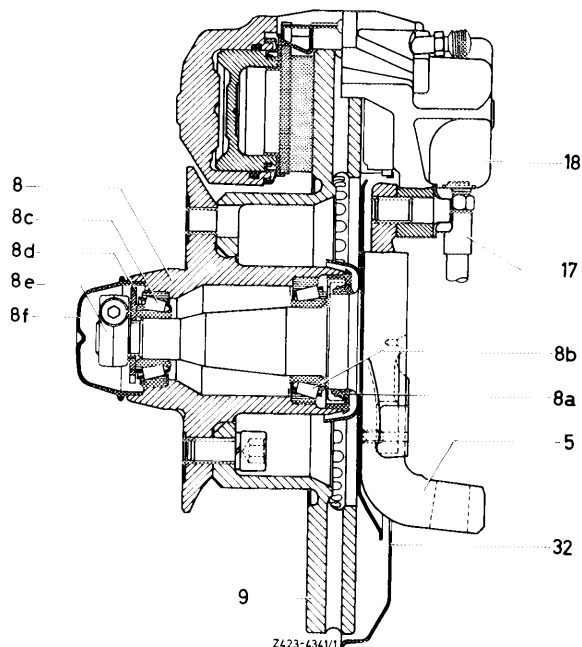

Front wheel hub with ABS

- | | | | |
|----|--------------------------------|-----|-----------------|
| 5 | Steering knuckle | 8f | Wheel cap |
| 8 | Wheel hub | 8h | Pull-off plate |
| 8a | Radial sealing ring | 9 | Brake disc |
| 8b | Tapered roller bearing inside | 32 | Cover plate |
| 8c | Tapered roller bearing outside | 42 | Rpm sensor |
| 8d | Washer | 42a | Fastening screw |
| 8e | Clamping nut | | |

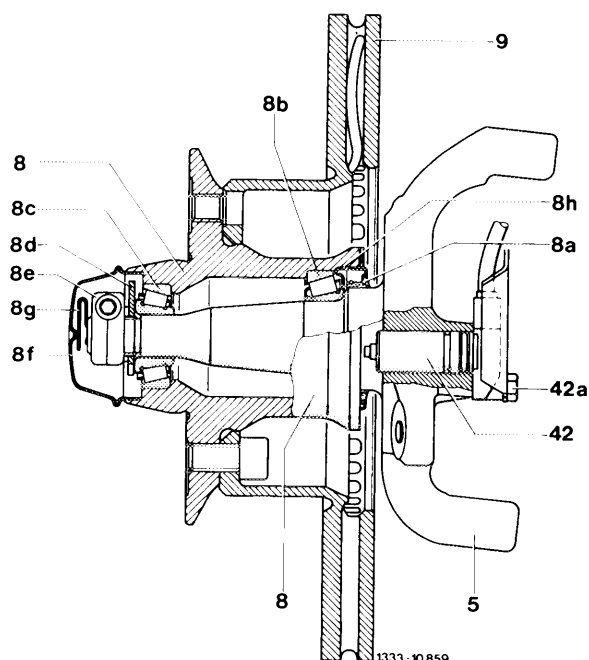

8 Tighten hex. socket screw of clamping nut and check end play once again.

Note: With wheel bearing end play correctly adjusted, the washer located between the outer tapered roller bearing and the clamping nut should just barely permit turning by means of finger. Always adjust wheel bearing end play with dial gauge.

9 Complete additional checkup by turning washer between inner race of outer tapered roller bearing and clamping nut.

10 Insert contact spring for radio suppressor.

11 Fill wheel hub with specified grease up to approx. edge of bead.

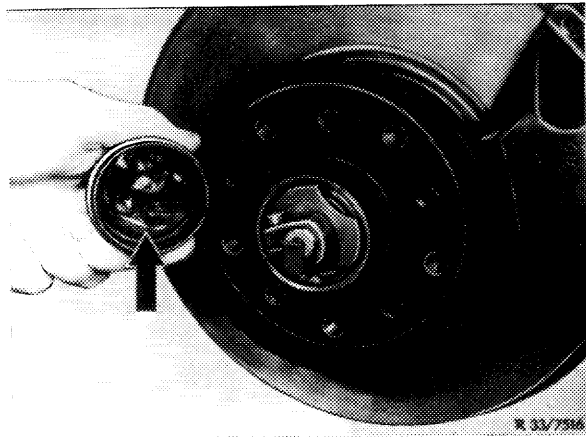

12 Press-on wheel cap with installer (89).

13 Mount front wheel, lower vehicle.

