

33–600 Checking the front axle carrier

Special tools

Set of measuring components for front axle carrier	115 589 16 23 00
Set of measuring rods for measuring distortion and bends	115 589 17 23 00
Inspection device for axle carrier	115 589 04 23 00
Beam compass, measuring length 1500 mm	000 589 35 19 00

Commercially available tools

Height measuring device size III	e.g. Messrs. Stiefelmayer, D-7300 Esslingen Order No. 5
----------------------------------	--

Note

The set of measuring components permits checking the front axle carrier either on inspection device for axle carriers or on measuring table.

To check the front axle carrier for distortion on receiving points of front axle suspension the measuring components can also be placed on Celette frame straightening bench.

Preparations for Measuring

- 1 Place measuring components into provided holes of inspection device for axle carriers or on a normal measuring table.
- 2 Knock rubber bearings for suspension of front axle to frame floor from cups in front axle carrier.
- 3 Introduce measuring rods (65a) for lower control arm bearing brackets into bearing brackets up to stop.

64a, b Receiving points for rear bearing; distance 760 mm
64c, d Receiving points for front bearing; distance 684 mm
70 Inspection device for axle carrier

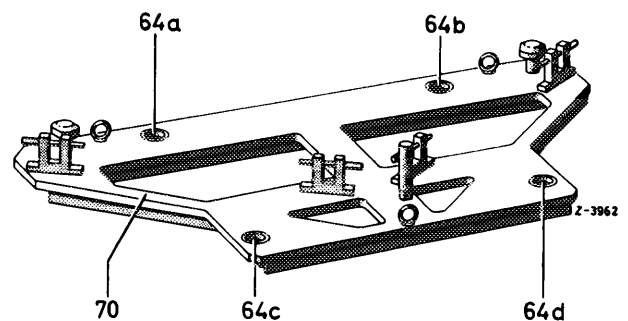

- A Receiving point for checkup on measuring table
- B Receiving point for checkup on inspection device for axle carriers
- C Upper receiving point
- h Reference height of measuring component in inspection device for axle carriers
- H Reference height of measuring component on measuring table
- 64a, Measuring component (rigid) for rear bearing
b h = 146 mm, H = 198 mm
- 64c Measuring component (rigid) for front bearing
h = 150 mm, H = 202 mm
- 64d Measuring component (adjustable) for front bearing

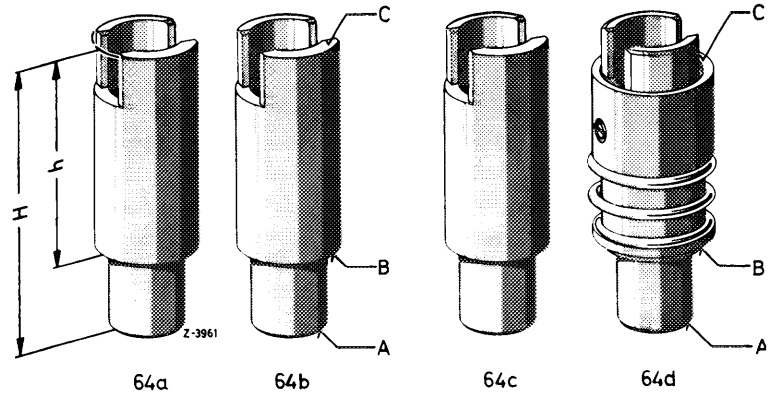

4 Place front axle carrier on measuring components with the bottom up.

Note: The measuring components carry the designations "front" („vorn“) and "rear" („hinten“).

- 1 Front axle carrier
- 64a, b Measuring components for rear bearing
- 64c Measuring component for front bearing
- 64d Measuring component for front bearing (adjustable)
- 65a Measuring rods for lower control arm bearing
- 70 Inspection device for axle carrier

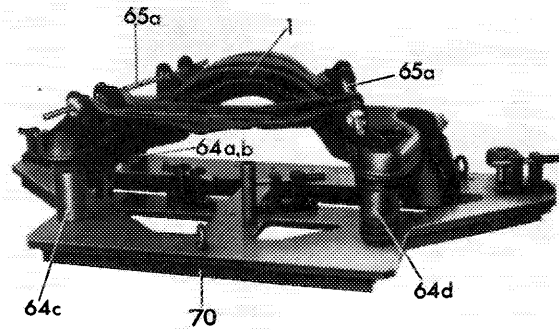

R33-5027

Note: The measuring rods are provided with one fixed locating ring each. The measuring rods (65a) for the lower control arm bearing brackets are additionally provided with one movable locating ring each.

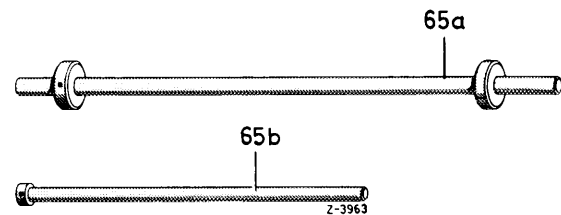

- 65a Measuring rod for lower control arm bearing bracket
- 65b Measuring rod for upper control arm bearing bracket

Checkup for Distortion

5 The inspection points to check for distortion are the cups for the rubber bearings of the front axle carrier suspension on frame floor. The permissible dimension is included in the adjusting possibilities of the measuring component (64d) starting from the nominal dimension in upward or downward direction.

Note: During the checkup for distortion the front axle carrier should rest against the rigid components (64a, b and c) at the top, while the sleeve of the adjustable component (64d) is placed against the bottom edge of the cup. The nominal dimension is attained when the pin is laterally in the bolt in the center of the hole in sleeve.

6 A checkup of the height between the inspection device or measuring table and the bearing brackets for the lower control arms serves as an additional checkup for distortion.

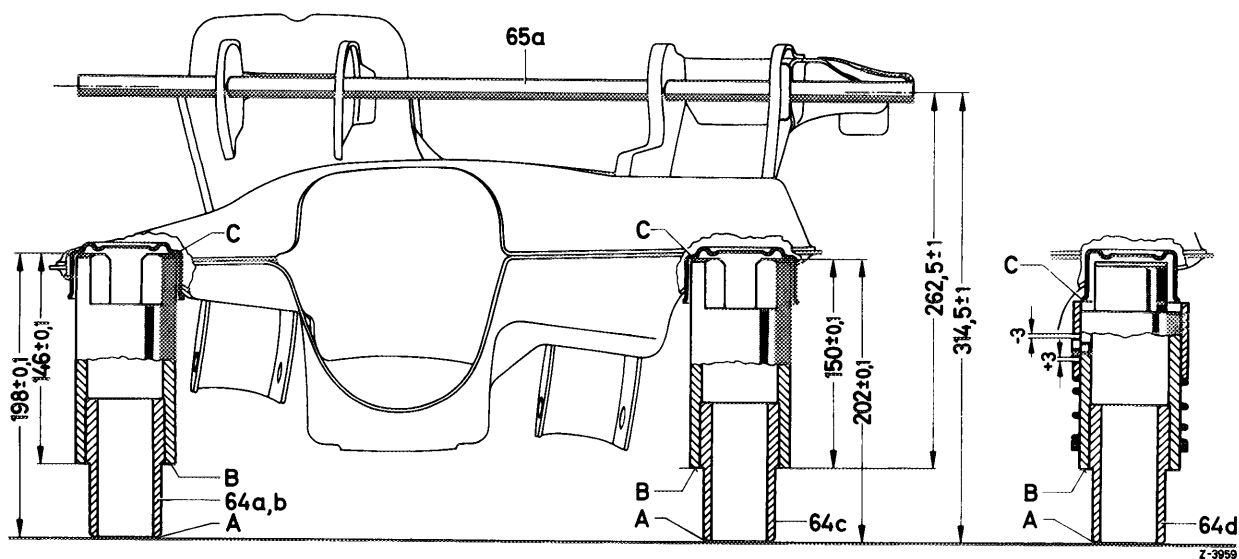

A Receiving point for checkup on measuring table
 B Receiving point for checkup on inspection device for axle carrier
 C Upper receiving point
 64a, b Measuring component (rigid) for rear bearing reference height 198 or 146 mm

64c Measuring component (rigid) for front bearing reference height 202 or 150 mm
 64d Measuring component (adjustable) for front bearing
 65a Measuring rod for lower control arm bearing brackets

Measurements are made in each case by means of a vertical tracer up to center of measuring rod. During these measurements the front and rear bearing cup on the side of the front axle carrier to be measured should rest against the measuring component.

1 Front axle carrier
 64a, b Measuring components for rear bearing
 64c Measuring components for front bearing (rigid)
 64 Measuring components for front bearing (adjustable)
 64e Locating sleeve
 65a Measuring rods lower control arm bearing
 70 Inspection device for axle carrier
 71 Vertical tracer

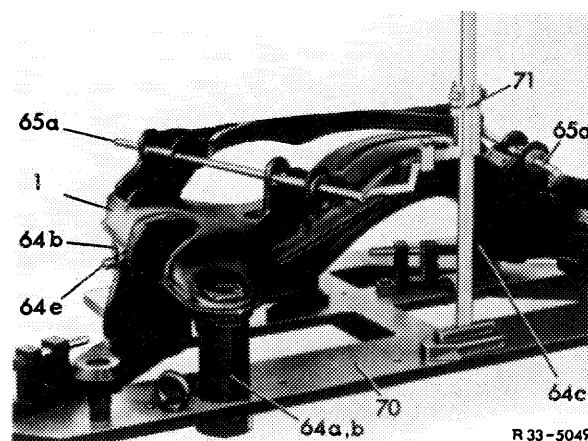

Note: The adjustable measuring component (64d) is fixed at the nominal height by means of the locating sleeve (64e). The locating sleeve must be selfmade according to dimensions in the figure.

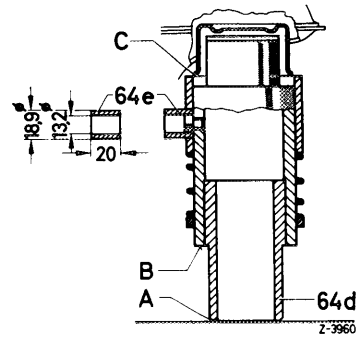

64d Adjustable measuring component
64e Locating sleeve

Checkup of Bends

7 Bends are checked in transverse direction with reference to the distances of the upper and lower control arm bearing brackets by means of the measuring rods (65a and b).

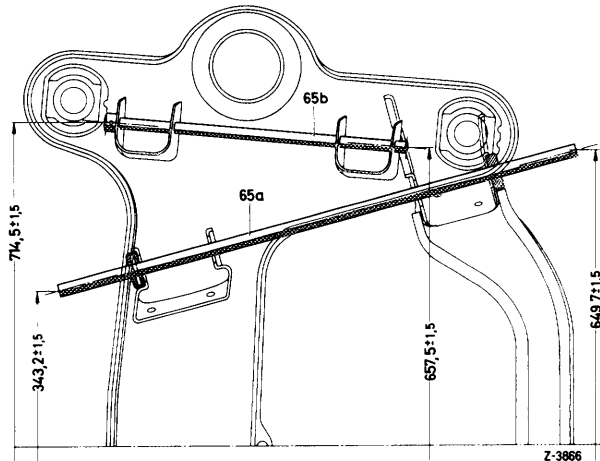

65a Measuring rods for lower control arm bearing brackets
65b Measuring rods for upper control arm bearing brackets

8 The measurements are made with a suitable beam compass. The center bores of the measuring rods serve as measuring points.

Note: The beam compass (72) shown in the figure is a conventional compass of 1,500 mm measuring length, fine adjustment with vernier and round measuring tips.

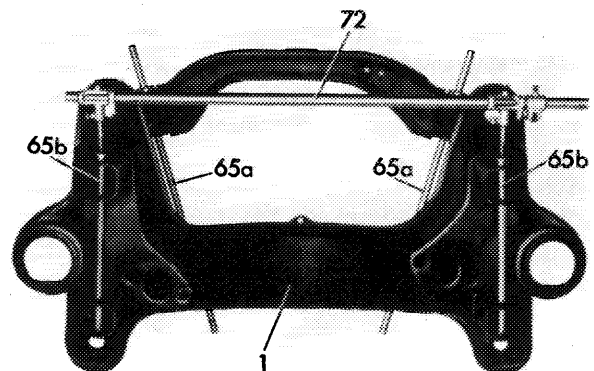
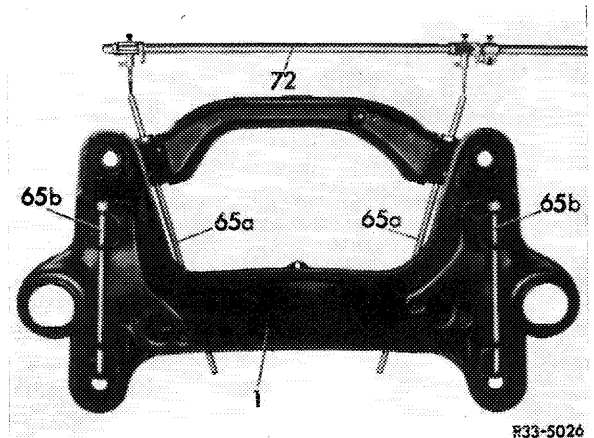

1 Front axle carrier
65a Measuring rods for lower control arm bearing
65b Measuring rods for upper control arm bearing
72 Beam compass

R33-5025