

## 35–530 Replacement of radial sealing ring on drive pinion





Rear axle center piece installed.

### Tightening torques

Nm

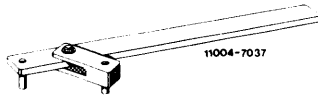
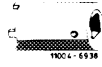
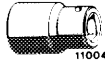
Lock nut of propeller shaft	2-piece		30–40
	3-piece	front	30–40
		rear	200

### Special tools

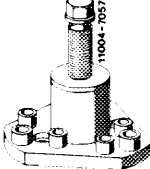
Holding wrench for universal flange 	11004-7037	116 589 10 07 00
Socket 3/4" square for slot nut on universal flange 	11004-6938	115 589 01 07 00
Socket 30 mm double hex. 3/4" square for double hex. collar nut on universal flange 	11004-10696	126 589 02 09 00
Thrust piece for radial seal (component of remover and installer for drive pinion) 	11004-10980	116 589 12 61 03
Torque measuring tool for friction torque of rear axle drive 30–600 Ncm 	11004-7074	001 589 49 21 00
Connection 3/4" square head to 1/2" square socket 	11004-6362	100 589 02 59 00
Puller for universal flange 	11004-7057	116 589 19 33 00

## Removal

### Models 107, 116, 126

- 1 Remove exhaust system (49–100).
- 2 Unscrew shielding plate.

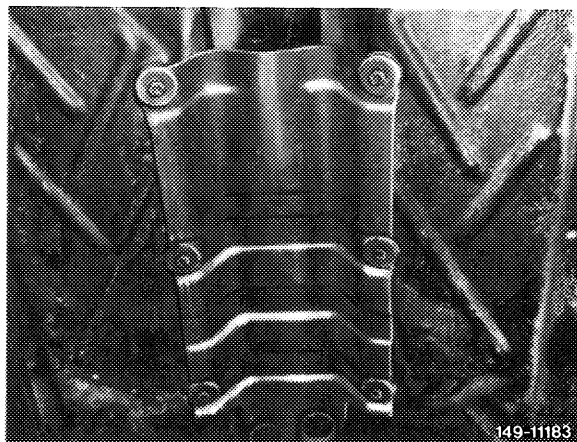

### All models

- 3 Loosen clamping nut and unscrew propeller shaft intermediate bearing on frame floor.

**Note:** On 3-piece propeller shaft loosen front lock nut only.

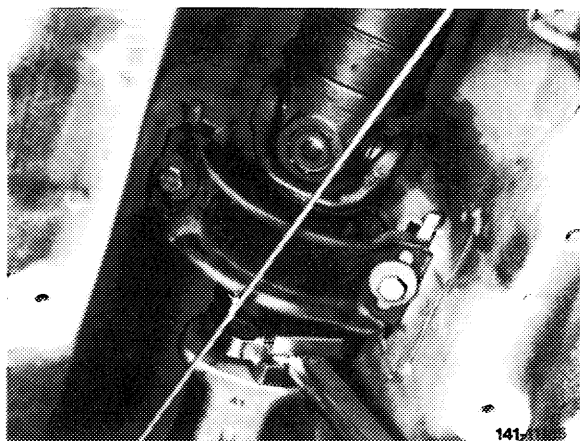

- 4 Unflange propeller shaft from rear axle and push forward out of concentric alignment.
- 5 Measure friction torque of complete rear axle drive and write down.

### Attention!

When measuring friction torque, make sure that the rear axle shafts are approximately horizontal and that neither the brake pads on brake discs nor the brake shoes of the parking brake are wiping against drum.

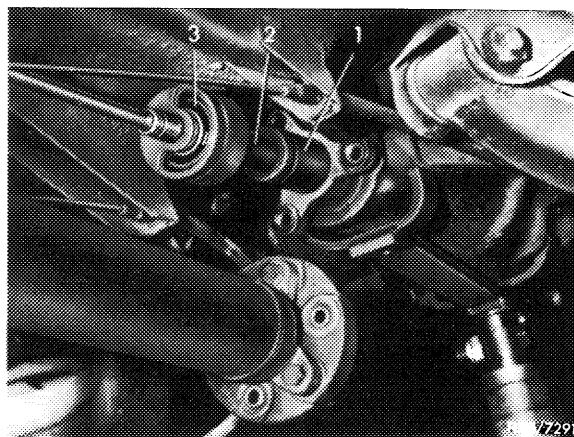

- 6 Plug holding wrench on universal flange and loosen slot nut or double hex. collar nut with slot nut socket or double hex. socket.

**Note:** Do not unlock on slot nut or double hex. collar nut with crush nut (since January 1974 or November 1981), but simply turn loose.

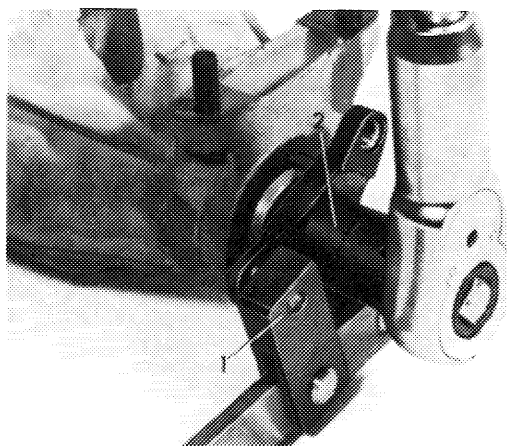

7 Pull universal flange from drive pinion, using puller, if required.

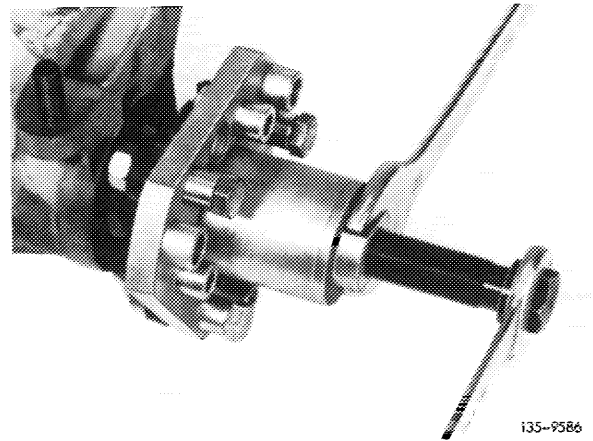

8 Force radial sealing ring out of rear axle housing by means of a screwdriver.

9 Check running surface for radial sealing ring on universal flange. Replace universal flange, if running surface is worn.

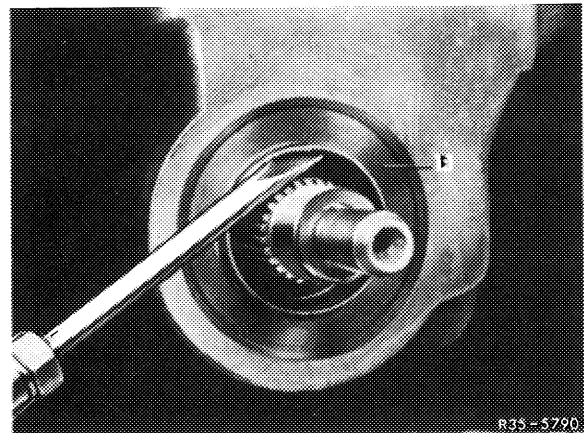

**Note:** Starting November 1979, only radial sealing rings with oil return feed thread and rubber-coated sheet-metal jacket will be available (B, arrows). This change eliminates the ground thread on universal flange.

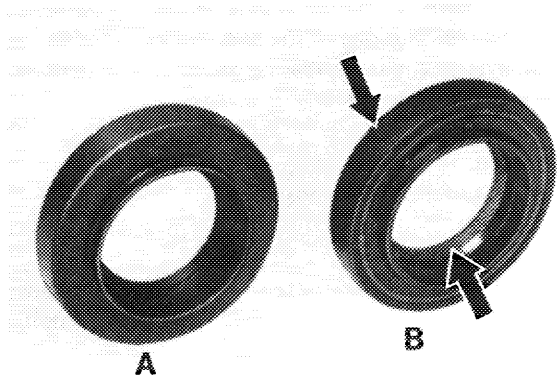

- A Radial sealing ring without ground thread (1st version)
- B Radial sealing ring with righthand thread and rubber-coated sheet-metal jacket (2nd version)

### Installation

10 Coat radial sealing ring with rubber-coated sheet-metal jacket on OD with rubber sliding compound "naphthalene H or hypoid gear oil" and knock-in up to stop in rear axle housing by means of thrust piece (1).

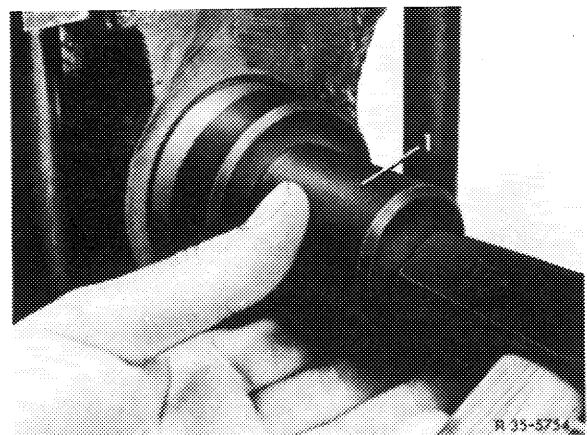

11 Plug-on joint flange and carefully tighten with a new slot nut until measured or recorded friction torque has been attained. Tightening torque of slot nut should amount to at least 180 Nm. If this minimum tightening torque is not attained, replace elastic spacing sleeve.

**Attention!**

On drive pinion of 1st version without groove on threads (A) mount self-locking slot nut (polystop slot nut, a) only.

On drive pinion of 2nd version with groove (B) optionally use a crush slot nut (b) with a groove on circumference, or a double hex. collar nut (c). Other installation combinations are not permitted.

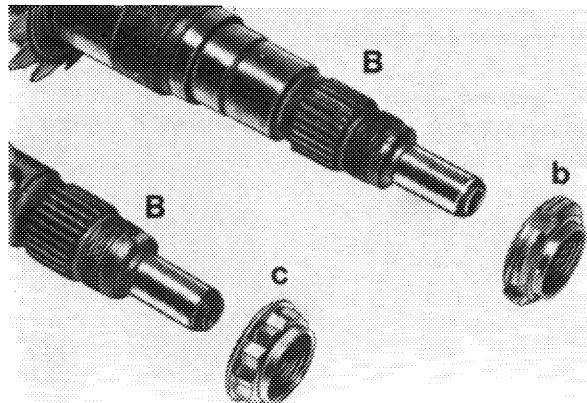
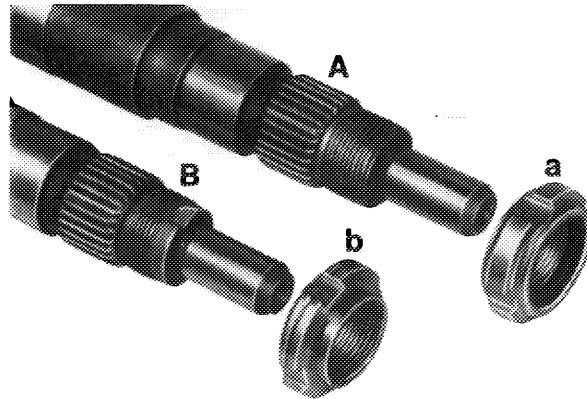

12 Peen crush slot nut or double hex. collar nut with a peening tool into one of the two grooves of drive pinion in such a manner that no gap shows up between groove and locking tab.

**Attention!**

Blows should not be too heavy.

Dimensions for peening tool: "a" = approx. 8 mm  
"b" = approx. 4 mm

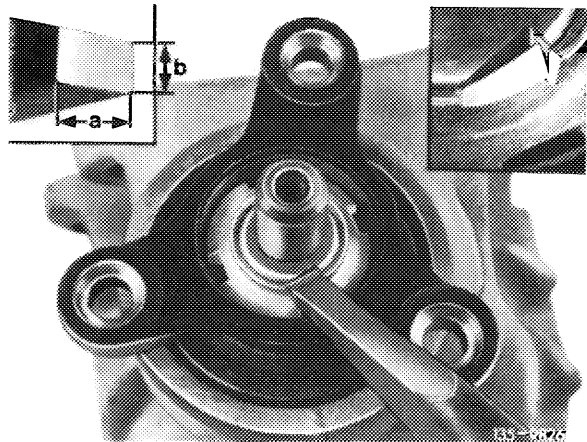

Crush slot nut

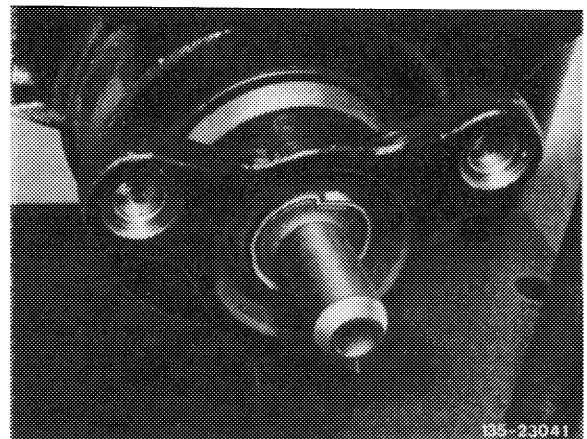

Double hex. collar nut

13 Attach propeller shaft to flange.

14 Attach propeller shaft intermediate bearing but do not yet tighten.

15 Fill rear axle housing with oil up to level of filler hole.

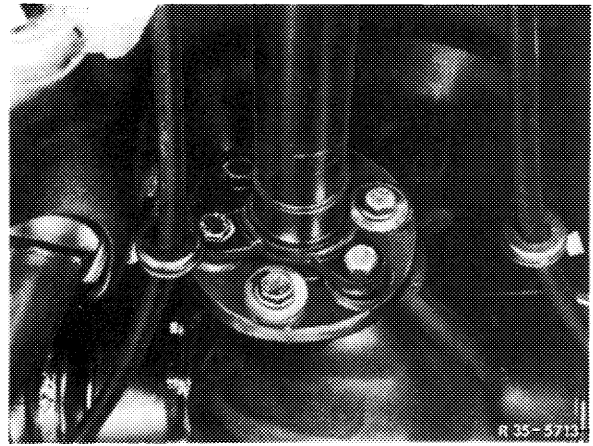

16 Tighten lock nut on propeller shaft to 30–40 Nm.

17 Tighten propeller shaft intermediate bearing.

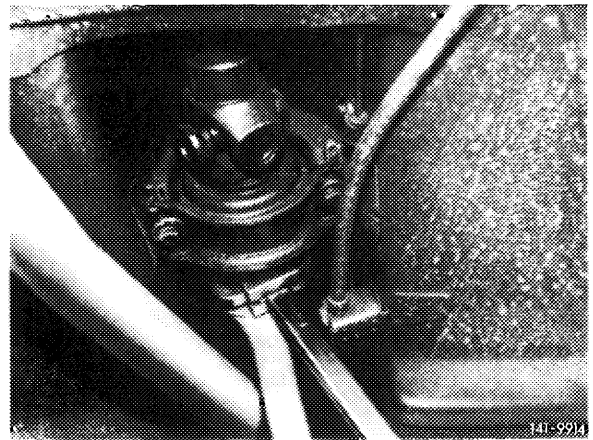

**Models 107, 116, 126**

18 Mount shielding plate.

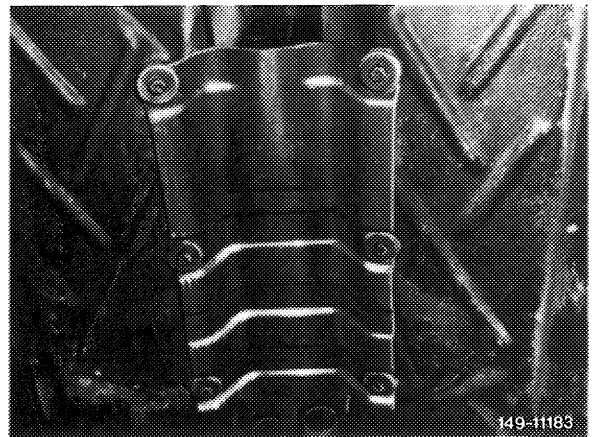

19 Install exhaust system (49–100).

