

## 42-100 Removal and installation of fixed caliper on front axle

### Data

Fixed caliper make	Teves S 2-56	Teves	Bendix	Teves <sup>1)</sup> M 4 - 40
Fixed caliper piston dia.	57	60		40
Shaft width for brake pads	77 + 0.15	90 + 0.15		
Disk contact width „a“	approx. 25			

<sup>1)</sup> 4-piston fixed caliper starting September 1985

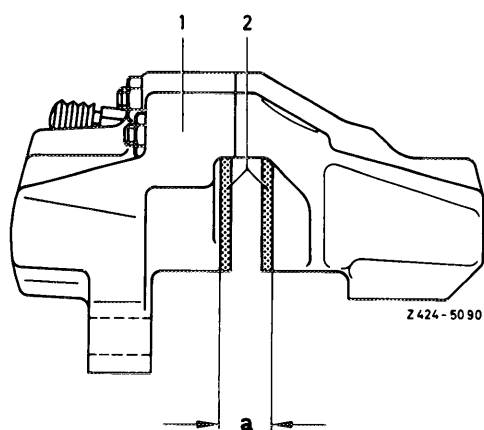

a Disc contact width  
1 Fixed caliper  
2 Brake pad

### Tightening torque

Nm

Fitted hex bolt for attaching fixed caliper to steering knuckle

115

### Conventional tool

Open double box wrench 9 x 11 mm

e.g. made by Hazet, D-5630 Remscheid  
order no. 612

### Note

For loosening and tightening brake lines use conventional double box wrench only.

### Removal

1 Pump brake fluid out of front brake circuit through an open bleeder plug.

2 Loosen brake hose (7) on brake line (4), then close brake hose and brake line immediately with rubber plug.

3 On vehicles with brake lining wear indicator, pull cables of clip sensor out of plug connection on fixed caliper.

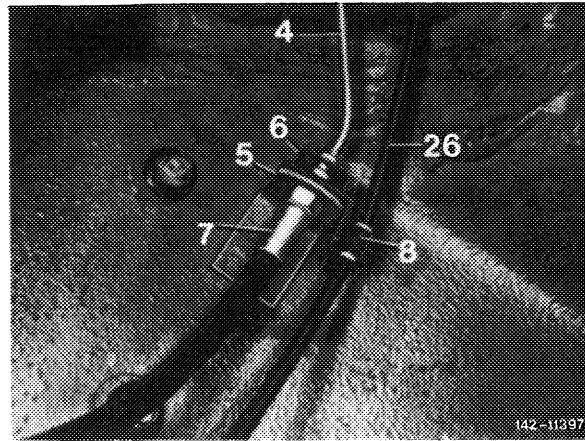

4 Loosen plug connection of brake lining wear indicator and brake hose (22) from fixed caliper (2). Close connection on brake hose and on fixed caliper with rubber plug.

5 Unbend locking plate (4), if installed, and unscrew hex. head fitted screw (3). Then remove fixed caliper from steering knuckle (6).

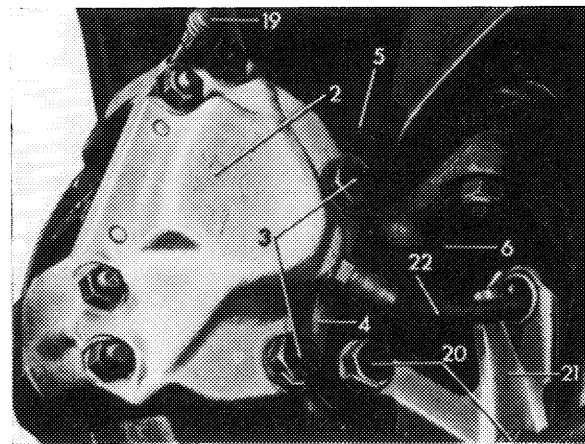

#### Installation

**Attention!** When installing a new fixed caliper proceed as follows:

The **piston dia.** of the fixed calipers of an axle **should be the same.** Up to August 1985 only the fixed calipers made by one and the same manufacturer may be installed on one axle.

Starting March 1980, modified fixed calipers with linings 17.5 mm thick and modified vented brake disks, which are identified by a groove at their circumference, are installed.

4-piston fixed calipers are installed since September 1985. The piston dia. is 40 mm.

Teves fixed caliper with 57 mm piston dia. and code No. 22

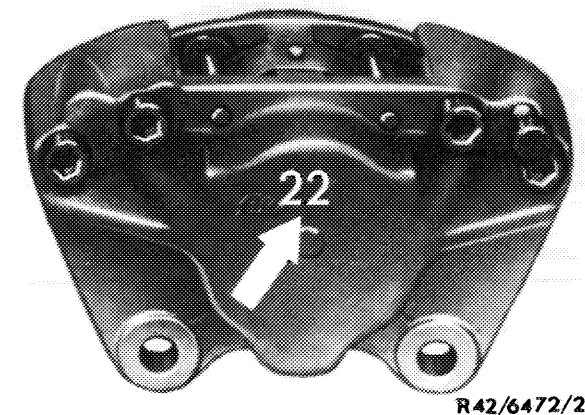

R42/6472/2

Teves fixed caliper with 60 mm piston dia. and code No. 60

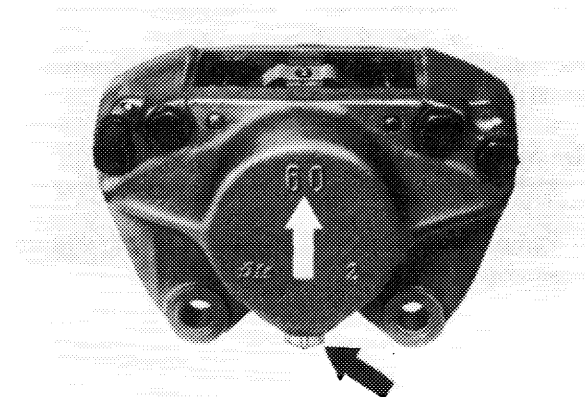

R42/7318

Bendix fixed caliper with 60 mm piston dia. and code No. 60

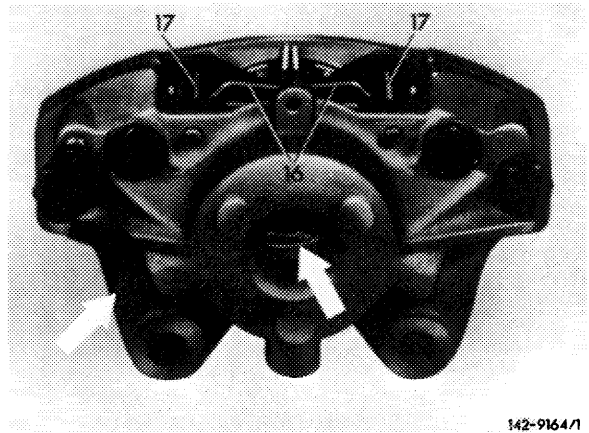

Teves 4-piston fixed caliper with 40 mm piston dia.

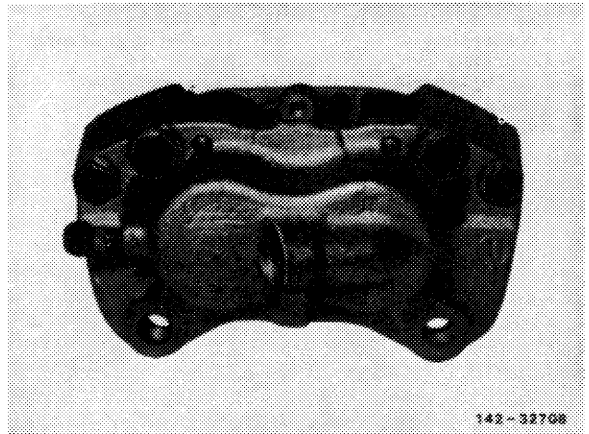

6 Attach fixed caliper to steering knuckle (6) using a new locking plate (4) with fitted hex. screws (3) or self-locking fitted hex. screws (3) and tighten to 115 Nm. Secure with locking washer, if required.

**Note:** Self-locking fitted hex. screws are installed since end of 1976. Fitted hex. screws may be used only once.

If the screw-in torque of the new self-locking hex. screws is very high, clean threads in steering knuckle from residual glue of micro-encapsulated screws by means of a tap M 12 x 1.5.

During reconditioning jobs (if the fixed caliper is not replaced), the original fastening method:

- a) screws with locking plate or
- b) self-locking screws should be maintained.

When renewing fixed calipers, use a locking plate also with self-locking screws for safety reasons.

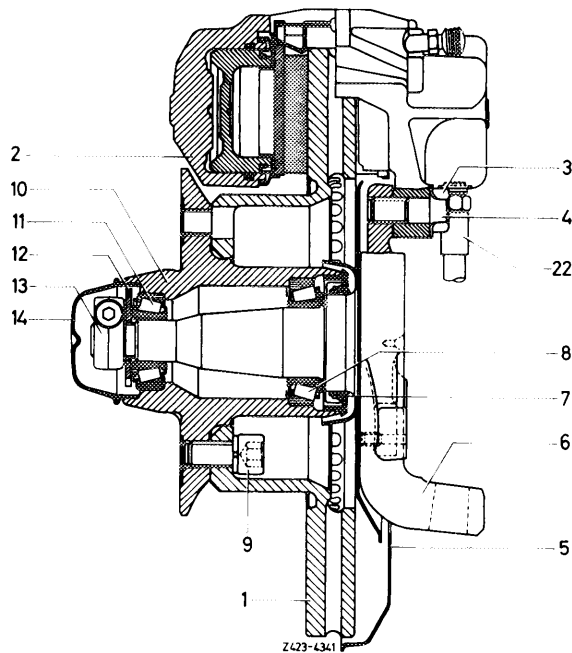

- |                          |                                    |
|--------------------------|------------------------------------|
| 1 Brake disc             | 9 Hex. socket screw with snap ring |
| 2 Fixed caliper          | 10 Front wheel hub                 |
| 3 Hex. head fitted screw | 11 Tapered roller bearing          |
| 4 Locking plate          | 12 Washer                          |
| 5 Cover plate            | 13 Clamping nut                    |
| 6 Steering knuckle       | 14 Hub cap                         |
| 7 Sealing ring           | 22 Brake hose                      |
| 8 Tapered roller bearing |                                    |

7 Introduce brake hose (22) through bracket (21), making sure that the guide grommet of the bracket is not damaged. Then attach brake hose to fixed caliper.

8 On vehicles with brake lining wear indicator, attach plug connection to fixed caliper. Insert cable of clip sensors into plug connection.

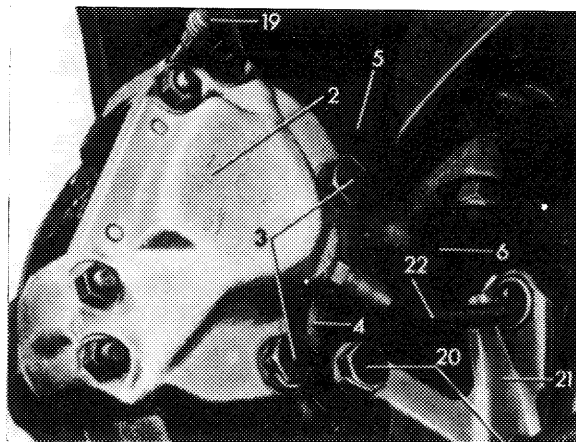

9 Connect brake line (4) to brake hose (7), making sure that the brake hose is not twisted.

**Attention!**

Holder (5) is provided with a double hexagon safety plate (8). Insert brake hose (7) into safety plate in such a manner that it will not wipe anywhere at left and right at full steering lock.

- |                          |
|--------------------------|
| 4 Brake line             |
| 5 Bracket on frame floor |
| 6 Brake hose holder      |
| 7 Brake hose             |
| 8 Locking plate          |
| 9 Cap screw              |

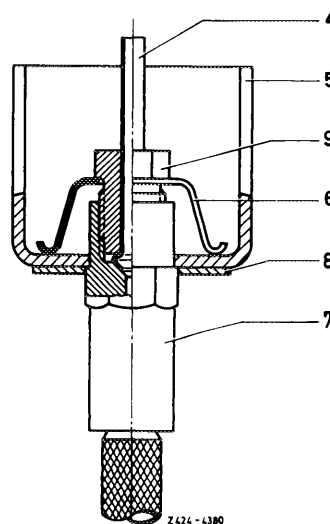

10 Bleed front wheel brake circuit (42–010).

**Attention!**

**Checking brake system for leaks!**

Upon bleeding, actuate brake pedal energetically several times to establish the correct play between brake disc and brake pad. Then, with the engine running, complete leak test by actuating brake pedal at approx. 200–300 N. The established pressure should hold up for some time, while brake pedal cannot be floored any further. Check all connections for leaks. If required, top up brake fluid in expansion tank of tandem main cylinder.