

## 42–155 Replacement of piston seal on rear axle fixed caliper

### Data

Fixed caliper make	Teves	Bendix	Girling
Housing dia.	37.99 38.03		38.17 38.22
Shaft width for brake pads	62 + 0.15		

### Lubricant

ATE brake cylinder paste

### Special tools

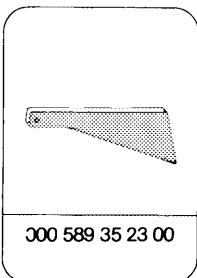
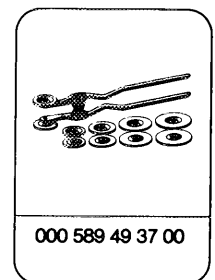
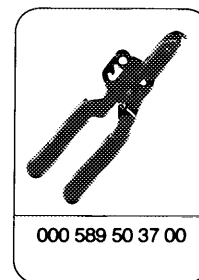
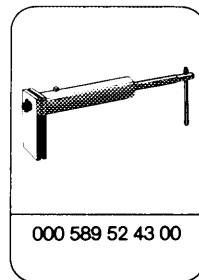
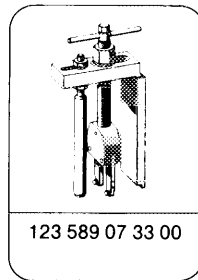
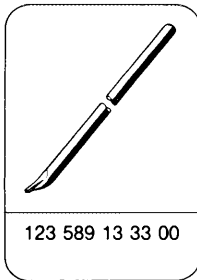

### Conventional tool

Open double box wrench 9 x 11 mm

e.g. made by Hazet, D-5630 Remscheid  
order no. 612

## Note

Do not separate the two halves of the fixed caliper since the fastening bolts are tightened to a definite torque by the manufacturer.

When renewing piston seal in Bendix fixed caliper, make sure that during removal of dust cap, the pressed-on ring is not pushed off (refer to arrow). The ring is not available as a spare part. If the ring is corroded, experience has shown that the cylinder bore is also damaged. In such a case, exchange complete fixed caliper.

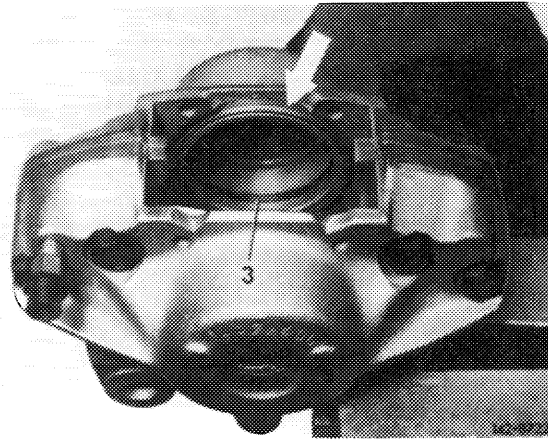

## Removal

- 1 Remove brake pads (42–160).
- 2 Force dust cap (9) from housing by means of a screwdriver.

Teves version

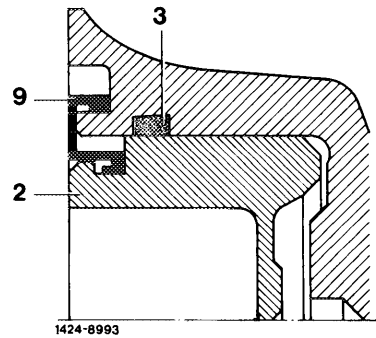

Bendix version

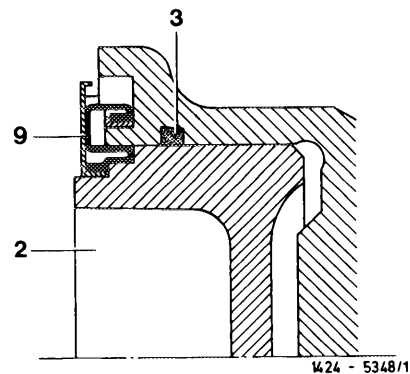

Girling version

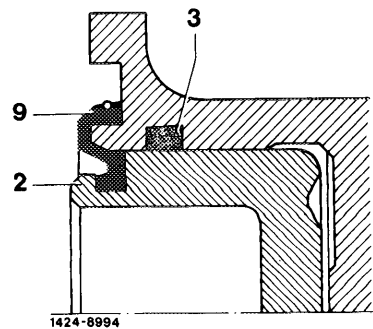

3 Hold one piston (2) in fixed caliper in place by means of resetting device (031). Then carefully press out opposite piston by means of compressed air.

**Note:** If the pistons are rusted down, install new fixed caliper.

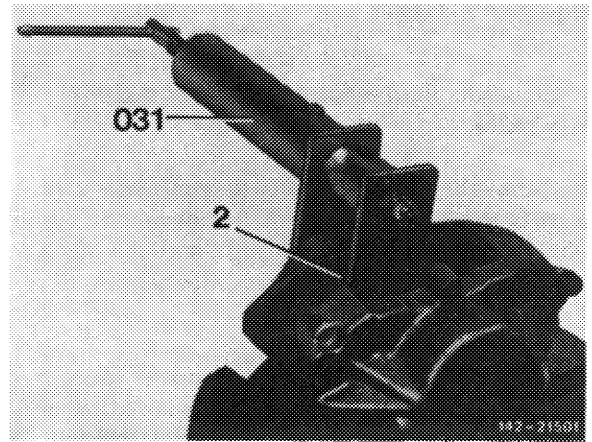

4 Remove piston seal (3) from groove of cylinder bore.

Teves version

- 1 Fixed caliper
- 2 Piston
- 3 Piston seal
- 4 Brake pad
- 5 Holding pin
- 6 Brake disc
- 9 Dust cap
- 10 Cross spring

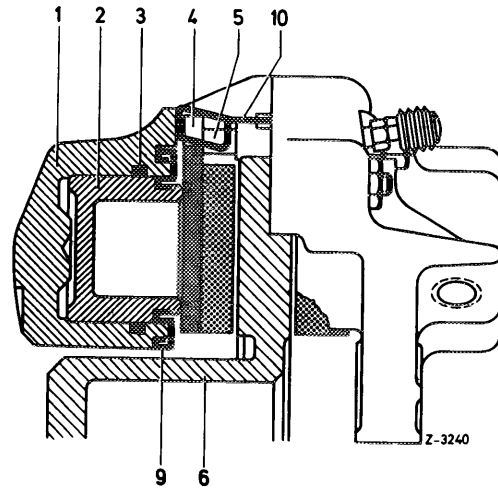

Bendix version

- 1 Fixed caliper
- 2 Piston
- 3 Piston seal
- 4 Brake pad
- 5 Holding pin
- 6 Brake disc
- 9 Dust cap
- 10 Holding spring for lining

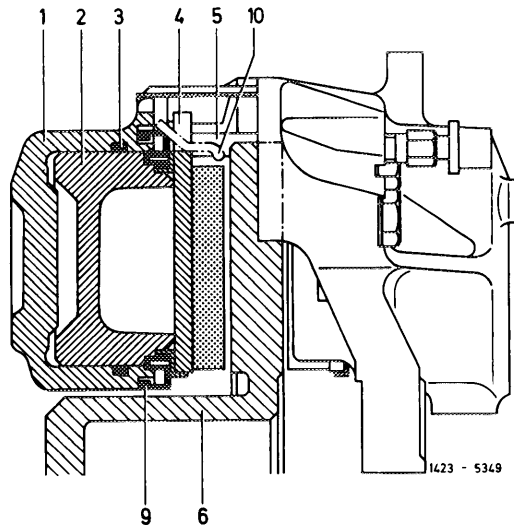

Girling version

- 1 Fixed caliper
- 2 Piston
- 3 Piston seal
- 4 Brake pad
- 5 Holding pin
- 6 Brake disc
- 9 Dust cap
- 10 Holding spring for lining

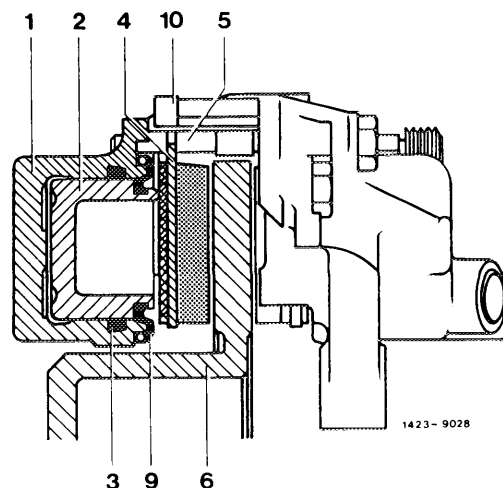

## Inspection and repair

---

- 5 On Bendix fixed caliper, remove heat shield (7) from piston.
- 6 Remove deposits on piston with a soft brass wire brush or a rough cleaning cloth. Do **not** wipe on piston with polishing cloth or emery cloth, since this might damage the chrome-plated surface. Replace piston if chrome surface is damaged.
- 7 Check cylinder bores of fixed caliper for wear. Replace complete fixed caliper if bores are scored or rusted. Remove small, minor rust spots in bore with polishing cloth, heavier rust spots in front of piston seal groove with fine emery paper (380 to 500 grain).

## Installation

---

- 8 Coat new piston seal (3) slightly with ATE brake cylinder paste and insert into groove of cylinder bore.

**Note:** When reconditioning Bendix fixed caliper, make sure of a tight and perfect seat of pressed-on ring (refer to arrow).

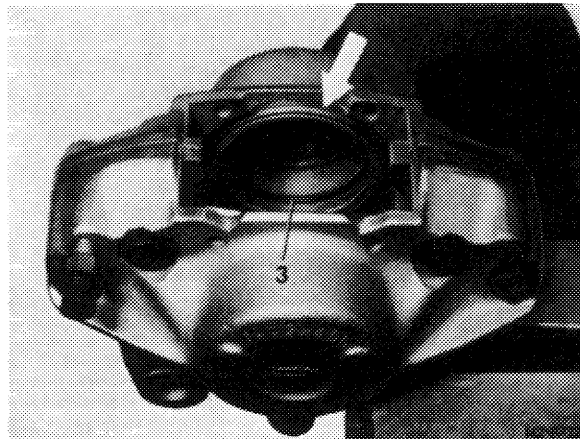

- 9 Insert piston (2) into bore of fixed caliper. Check position of piston in fixed caliper with piston gauge (019).

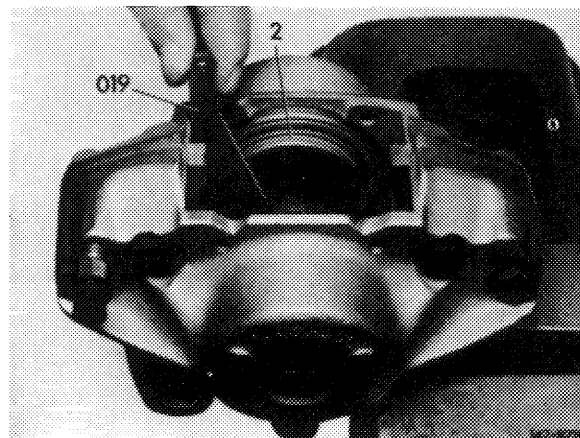

**Note:** When installing pistons, watch out for different piston versions.

Teves version

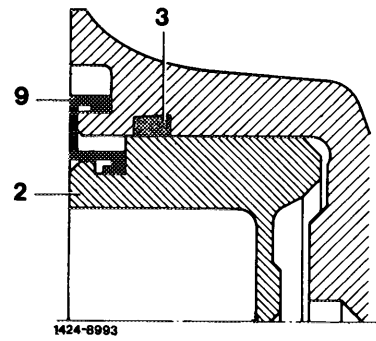

Bendix version

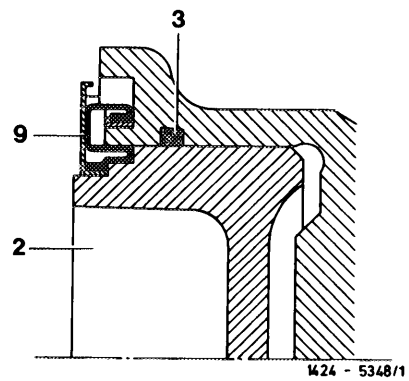

Girling version

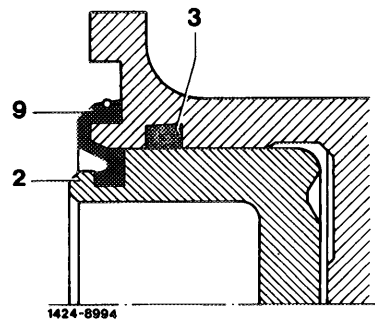

10 If required, move piston into correct position by means of piston rotating pliers (020).

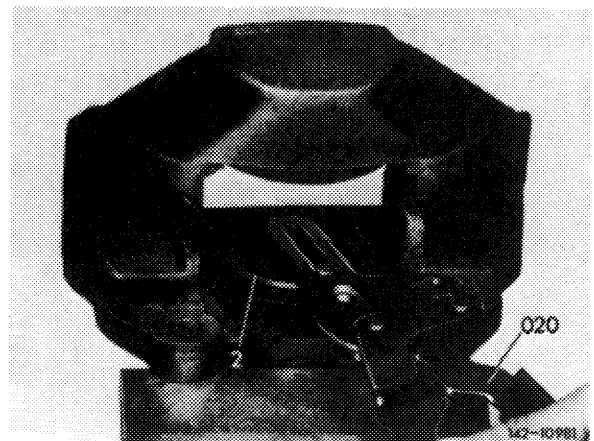

**Attention!**

Install piston in such a manner that with fixed caliper installed the elevation (marked black) on piston is pointing upwards. While braking, this elevation will cause a one-sided contact of brake pads. This in turn will reduce a trend towards squealing.

Piston position diagonal swing axle

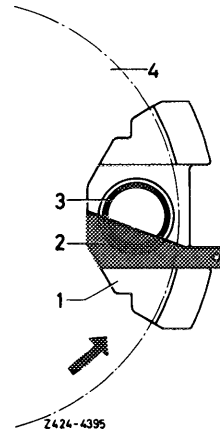

On fixed caliper for diagonal swing axle with starting torque compensation, the elevation on piston must be at bottom.

Piston position diagonal swing axle with starting torque compensation

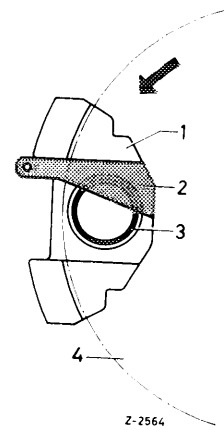

11 On Teves fixed caliper, mount dust cap (9) on piston (2) and position against collar of fixed caliper.

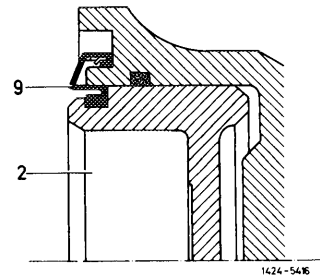

12 Press dust cap (9) on collar of fixed caliper by means of pliers (026) and pertinent discs (027).

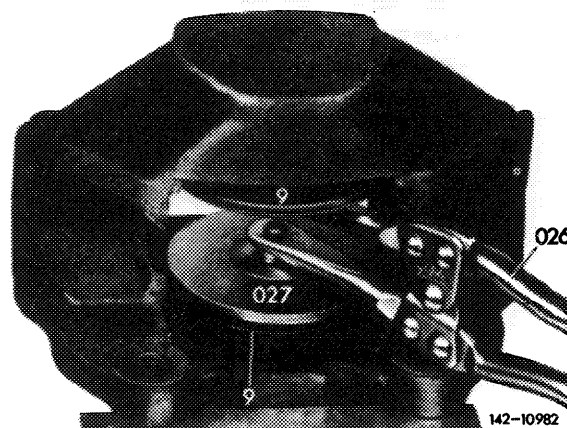

13 On Bendix fixed caliper, press heat shield (7) on piston in accordance with piston position.

**Attention!**

The elevation on piston should project at least 0.1 mm beyond heat shield.

**Note:** The rear wheel fixed caliper made by Teves has no heat shield.

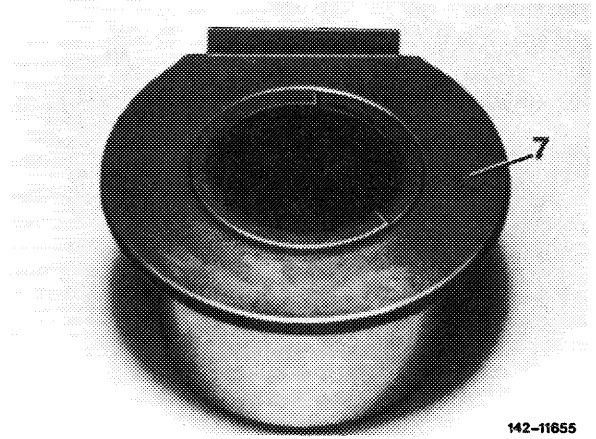

142-11655

14 Place dust cap (9) on piston (2).

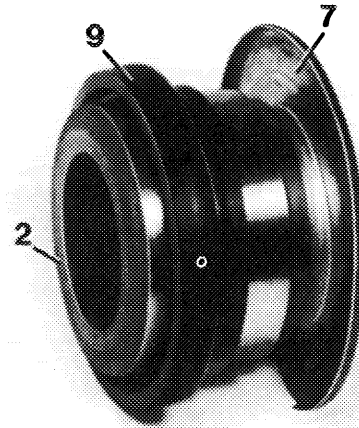

142-11654

15 Mount dust cap (9) on collar of fixed caliper with a blunt assembly needle. Then push piston completely back until dust cap (9) is perfectly seated on piston collar.

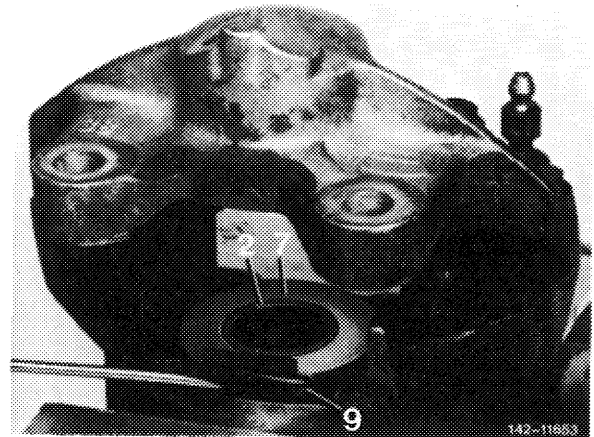

142-11653

16 On Girling fixed caliper, mount dust cap (9) on piston (2).

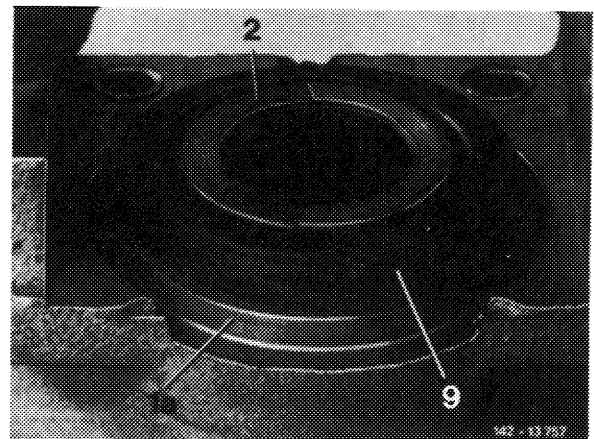

142-13787

17 Push dust cap (9) over web (1a) of fixed caliper and attach with clamping ring (10).

18 Install brake pads into fixed caliper (42–160).

