

43–350 Removal and installation of brake unit

Data

Brake unit		Teves T 51/1802 Teves T 52/225 T	Girling LSC 115 T Teves T 52/4 A 225-210
Diameter	Inch	9	8/9
	mm	228.6	203/228.6
Boosting factor		approx. 4.5	approx. 5.6
Tightening torques			Nm
Hex. nuts for mounting brake unit to front end			15
Coupling nut of vacuum line on brake unit			30

Attention!

If externally no brake fluid loss can be observed, check whether brake fluid has entered the brake unit through a leaking secondary seal in tandem main cylinder. If so, proceed as follows:

1. Do **not** remove brake unit.
2. Draw off brake fluid.
3. If more than 100 cc brake fluid are in brake unit, the brake unit has also to be exchanged.

Note: The flexible diaphragm is resistant to brake fluid, but not the reaction disk and the plate valve in control member. The brake fluid may therefore only be drawn off with the brake unit installed. Up to 100 cc no brake fluid can come to the reaction disk or the plate valve with installed brake unit.

Removal

- 1 Take connecting hose (7) off of master cylinder for models with a manual transmission.
- 2 Remove tandem master cylinder (42-310).
- 3 Detach vacuum line (8) at brake unit (6).

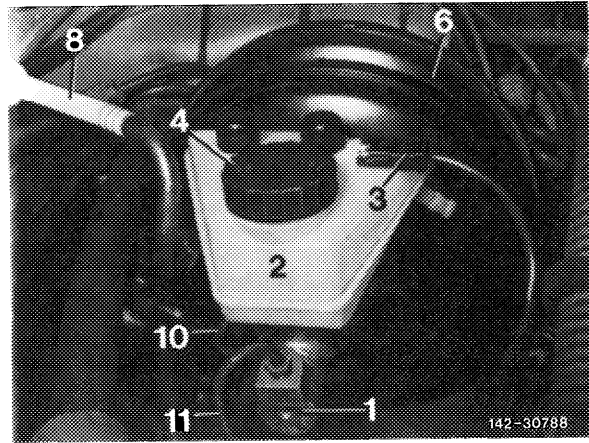

- 4 Remove rubber cover (18) at front end.

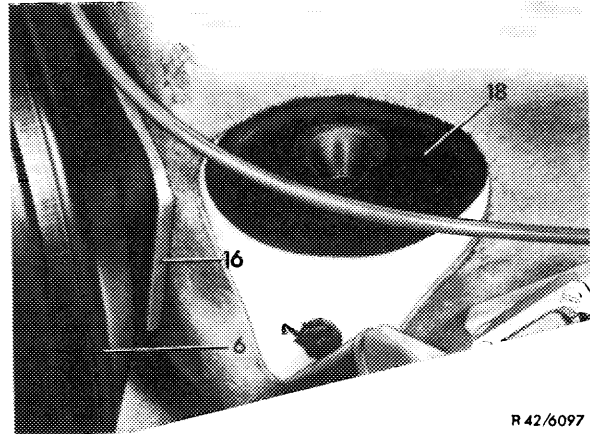

- 5 Unscrew hex. nut (9).

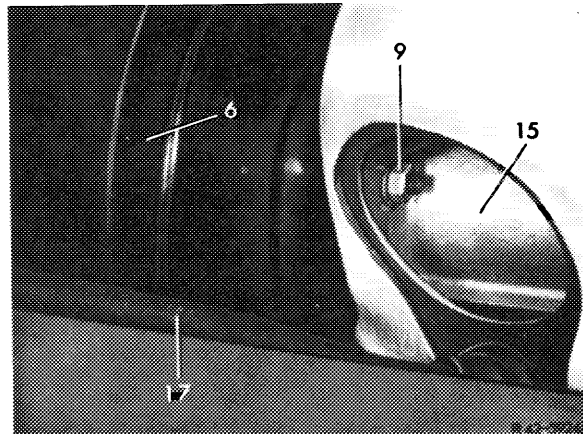

- 6 Unscrew cover below instrument panel in leg room (3) and pull downwards.

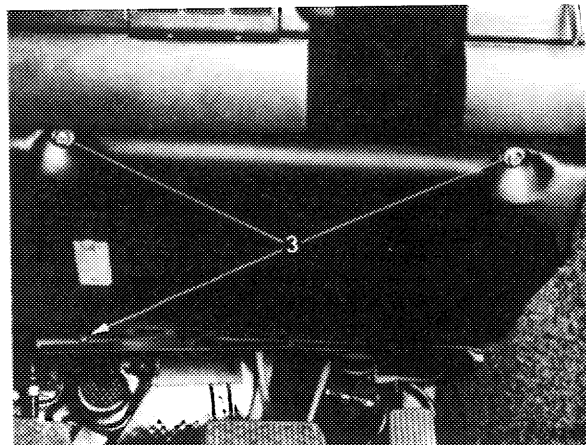

7 Push out leg room lamp (4), remove plug and pull cable out of cover.

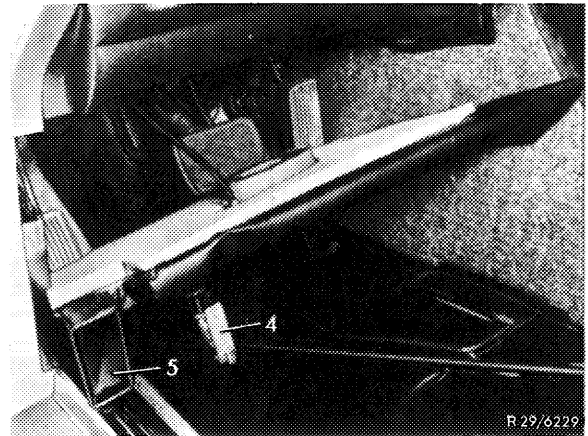

8 On 1st version, unscrew hex. screw (3) and remove bushing out of brake pedal (1), on 2nd version, remove lock (8) and pull out flange pin (7), so that push rod of brake unit on brake pedal is released.

9 Unscrew hex. nut for fastening brake unit to front end.

10 Remove brake unit.

Attention!

The control housing of brake unit is made of plastic and would break if not handled with care.

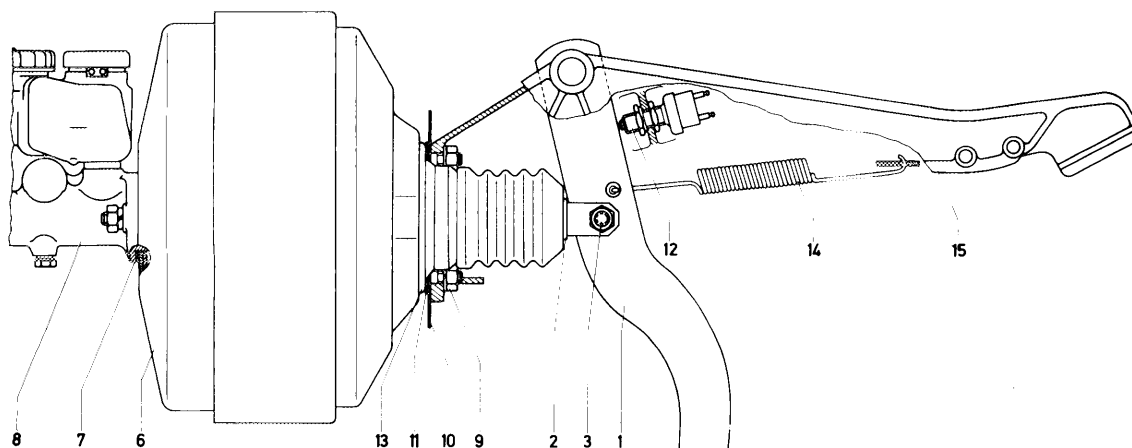

- 1 Brake pedal
- 2 Brake unit pressure rod
- 3 Hexagon head bolt with nut and lock washer
- 6 Brake unit
- 7 O-ring
- 8 Tandem master cylinder
- 9 Hexagon nut
- 9 Front end
- 11 Gasket
- 12 Stop light switch
- 13 Intermediate flange
- 14 Return spring
- 15 Carrier

Note: When installing brake unit make sure that rubber cup (7) is fastened correctly on pressure rod (2) and intermediate flange (13), and do not forget gasket (11).

Also check whether separate check valve is good. If in doubt, replace valve along with plastic lines (42-023).

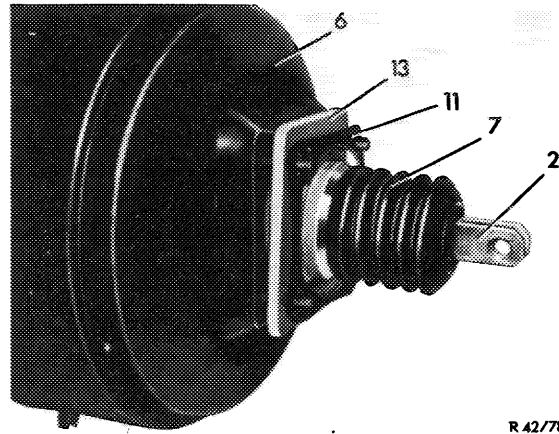

R 42/7889

Installation

11 Attach brake unit to front end. The lefthand upper hex. nut (9) is screwed in through an opening in front end from direction of engine compartment. Tighten hex. nuts to 15 Nm (1.5 kpm). Insert rubber cover after tightening hex. nut (9).

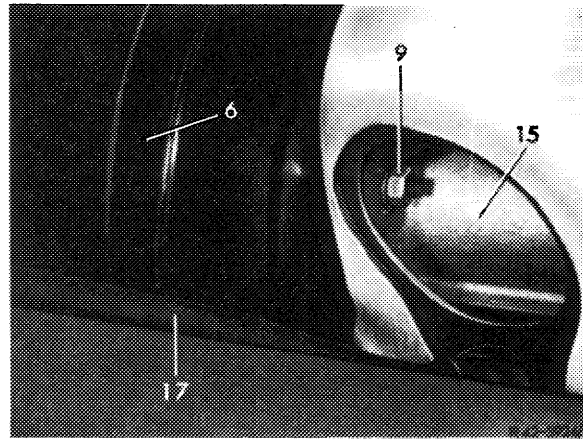

Note: Starting September 1979 the fork head of pushrod on brake unit and the brake pedal are modified. Instead of the hex bolt and the flange bushing used up to now, a flange bolt of 8 mm dia. together with a lock is now installed.

12 On first version, fasten pushrod (2) of brake unit to brake pedal (1) by means of bushing (4) and hex bolt (3).

1st version

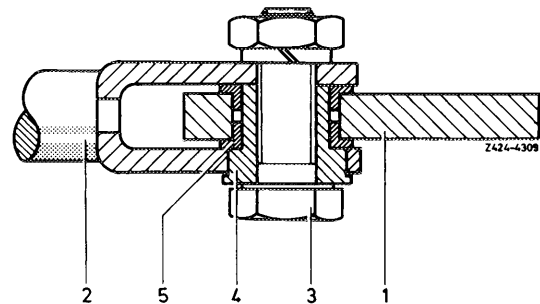

13 On second version starting September 1979 fasten pushrod (2) of brake unit to brake pedal (1) by means of flange bolt (7) and lock (8).

2nd version

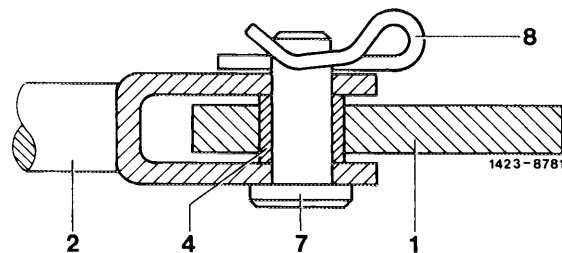

Attention!

When installing a brake unit with a new fork head and an old brake pedal install bushing (4), part no. 123 292 01 50, additionally into lever (1). Hex bolt (3) with snap ring and nut may be used again.

Fork head new, brake pedal old

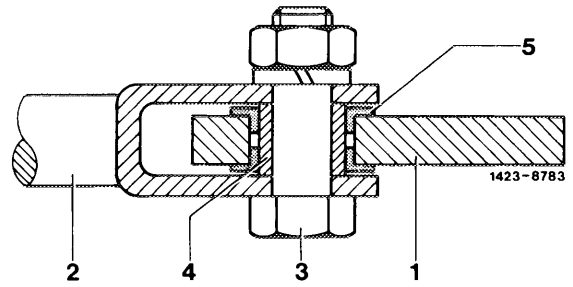

When installing a new brake pedal and a brake unit with an old fork head, install flange bolt (6), part no. 126 292 01 74, together with lock (8).

Brake pedal new, fork head old

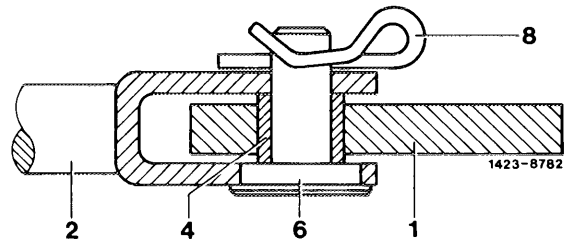

14 Pull cable for leg room lamp through cover. Attach plug and push leg room lamp (4) into cover.

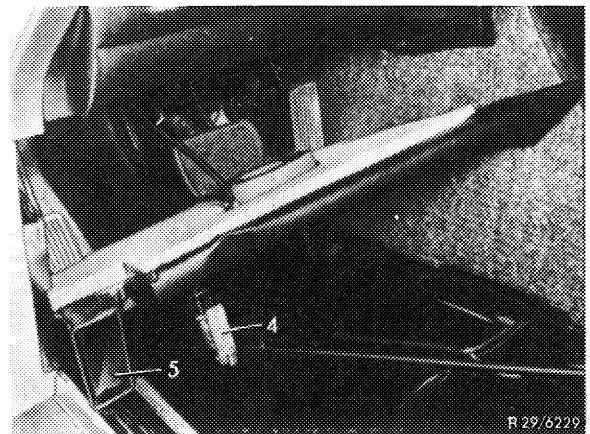

15 Introduce leg room cover and screw down.

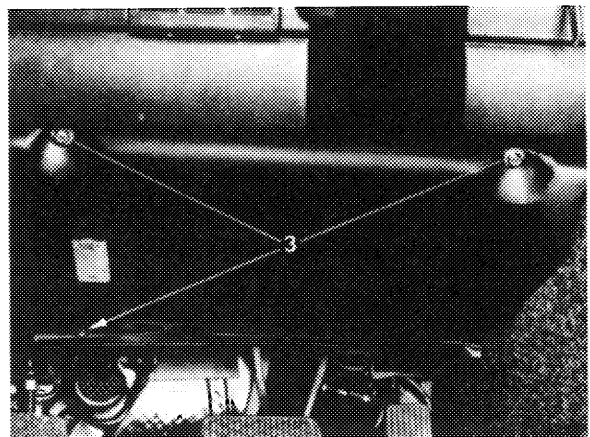

16 Connect vacuum line to brake unit, tighten coupling nut to 30 Nm.

17 Install tandem main cylinder (42-310).

18 On vehicles with manual transmission, attach connecting hose (7) to master cylinder on expansion tank.

