

Note

Steering couplings starting June 1973 are riveted and cannot be reconditioned.

Disassembly

1 Remove clip lock (1) from both bolts (8), remove washers (2 and 3) and plastic washers (4). Then pull lower flange (5) from upper flange (7) and remove both bushings (6).

- 1 Clip lock
- 2 Steel washer
- 3 Spring washer
- 4 Plastic washer
- 5 Lower flange
- 6 Bushing
- 7 Upper flange
- 8 Bolt

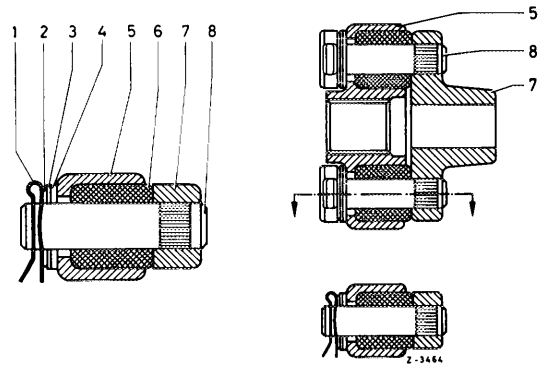

Assembly

2 Push new bushings (6) into lower flange. Slightly grease bolt (8) of upper flange, then slightly press upper flange into lower flange in a vise.

Mount plastic washers (4), spring washer (3) and steel washer (2) and insert clip lock (1).

Attention! Make sure that the clip locks are perfectly seated in bolt.

Top and bottom of both steering coupling versions are supported in plastic bushings. **Brake fluid and antifreeze will decompose these plastic bushings.**

When handling such fluids in engine compartment, proceed carefully and/or cover steering coupling.

To keep lubricant in place, do not spray directly on steering coupling with a steam jet sprayer.

Note: In the event of noise in steering coupling, apply thin oil, e.g. gear oil, in range of plastic bushings, while turning the steering several times to the left and to the right. Do not use "Caramba".