

## 46-412 Removal and installation of power steering

### Data

Steering	Part No.	Steering version	Type	Reaction piston dia. 1)	Pitch ball circ.	Ratio in center position i =	Total ratio in center pos. i =	Remarks
	107 460 13 01	LL	107.022					
	107 460 14 01	RL	107.023					
			107.024	11				
			107.042					
			107.043					
			107.044					
			1st version					
	114 460 17 01	LL	107.022					
	114 460 18 01	RL	107.023					
			107.024					
			107.042					
			107.043					
			107.044					
			2nd version	10				
	116 460 08 01	LL	107.022					
	116 460 09 01	RL	107.023					
			107.024					
			107.042					
			107.043					
			107.044					
			3rd version					
765.701					10,5	13,92	15,69	
	114 460 21 01	LL	107.022					
	114 460 22 01	RL	107.023					
			107.024	11				
			107.042					
			107.043					
			107.044					
			4th version					
	107 460 17 01	LL	107.022					
	107 460 18 01	RL	107.023					
			107.024					
			107.042					
			107.043					
			107.044					
			5th version	11,5				
	107 460 19 01	LL	107.022					
			107.023					
			107.024					
			107.042					
			107.043					
			107.044					
			6th version					
			107.025					
			107.026					
			107.045					
			107.046					

<sup>1)</sup> This steering is identified on steering case with code number "1" adjacent to closing cover for control valve (Reaction piston 11 mm dia. or 11.5 mm dia).

## Oil grade/filling capacity and oil level checkup

ATF refer to Specifications for service products page 236.2  
 or gear oil refer to Specifications for service products page 237

Filling capacity approx. 1.5 liter

Oil level checkup: With oil at operating temperature (approx. 80°C) the oil level in supply tank should reach up to punched-in or cast-in mark (approx. 20 mm below edge of tank). With cold oil and at ambient temperature, oil level 6–8 mm below mark. Use only perfectly clean oil for re-filling, since even minimum particles of dirt may lead to trouble in hydraulic system.

Tightening torques	Nm	(kpm)
Locking screws for attaching steering to side member of frame floor	70–80	(7–8)
Self-locking hex. nut to pitman shaft	160–200	(16–20)
Hex. socket screws to steering coupling	25	(2.5)
Castle nut to track rod and drag link	35	(3.5)
High-pressure expanding hose to steering	25–30	(2.5–3)
Return line to steering	35–40	(3.5–4)

## Special tools

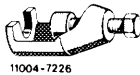
Puller for ball joints of track rod on pitman arm, intermediate steering arm and steering knuckle arm  186 589 10 33 00

Puller for ball joints of drag link on pitman arm and steering intermediate arm  111 589 08 33 00

Puller for ball joints of drag link on pitman arm and steering intermediate arm  123 589 09 33 00

Puller for pitman arm  100 589 04 33 00

Check screw for center position of steering  116 589 06 21 00

## Self-made tool

Assembly pin refer to illustration item 23

## Removal

1 Draw oil out of supply tank (2) of power steering pump by means of a syringe.

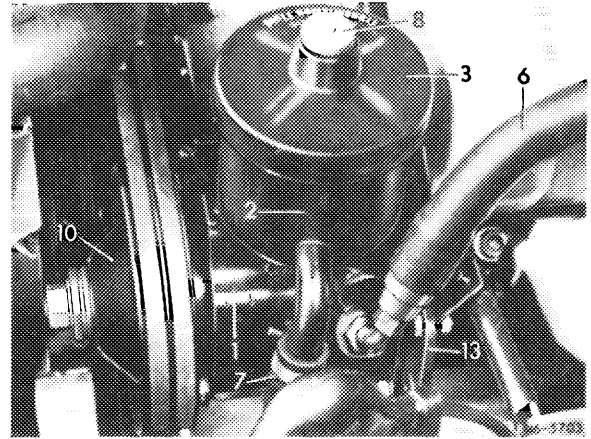

2 Loosen high-pressure expanding hose (10) and connecting pipe for return flow hose (11) on steering, while applying counterhold to connections on steering.

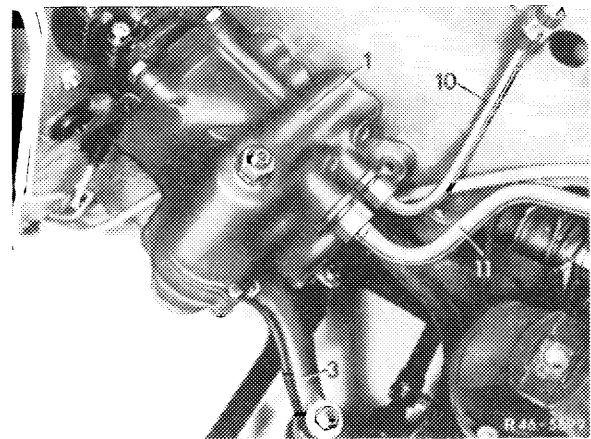

3 Close oil hoses and connecting points on steering with blind plugs.

4 Unscrew lower hex. socket screw (13) from steering coupling (12).

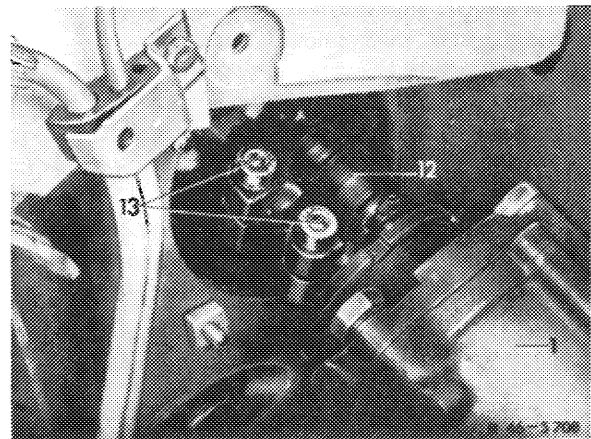

5 Uncotter castle nut of drag link and track rod and unscrew castle nut.

**Note:** If the steering has been exchanged and the pitman arm is not replaced, the drag link and the track rod on steering arm need not be released.

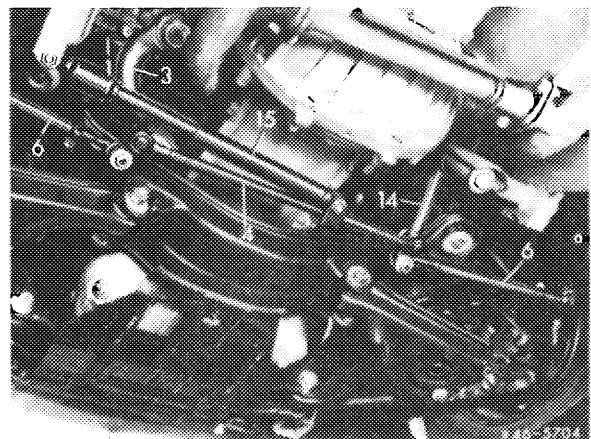

6 Push ball joint of track rod from pitman arm by means of puller.

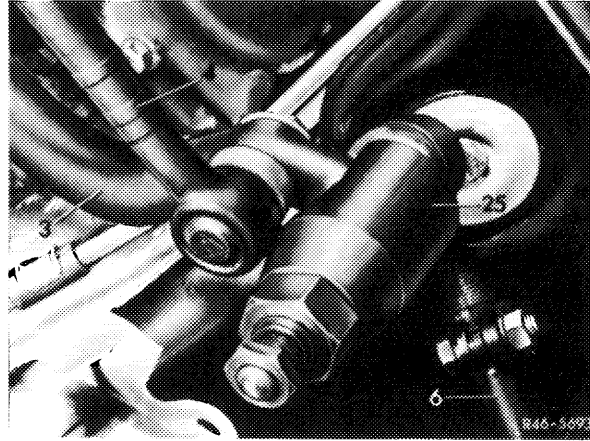

7 Push ball joint of drag link from pitman arm by means of puller.

**Note:** The drag link can also be pushed off with puller 123 589 09 33 00. To avoid damaging rubber sleeve on drag link of 2nd version, use puller 123 489 00 33 00 only if the bell head of puller has been refinished.

8 Unscrew self-locking hex. nut (9) from pitman shaft.

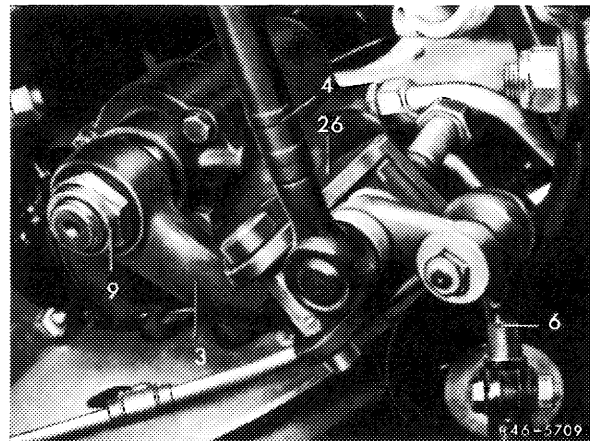

9 On vehicles with 8-cylinder engine remove rear exhaust system, then remove lefthand exhaust pipe on manifold.

10 Remove pitman arm(2) from pitman shaft (25) with puller (50).

11 Remove steering shaft (46-630, item 2-5). However, pull steering shaft upwards only to the extent that the steering coupling is no longer entering steering worm.

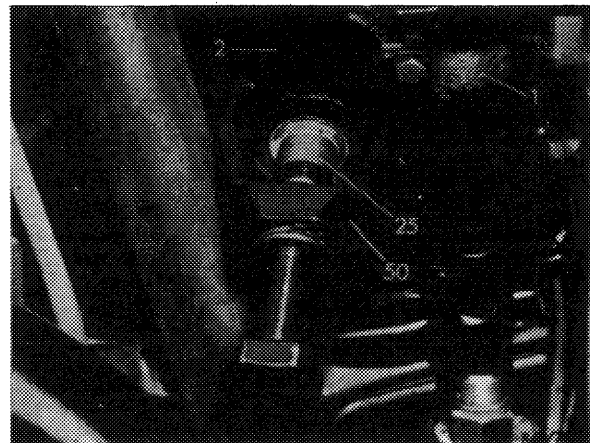

12 Unscrew locking screw (4) for attaching steering to side member of frame floor. Then remove steering in downward direction.

13 Upon removal of steering, drain oil from steering housing by turning steering worm completely to the left and to the right.

14 Remove steering coupling from steering shaft.

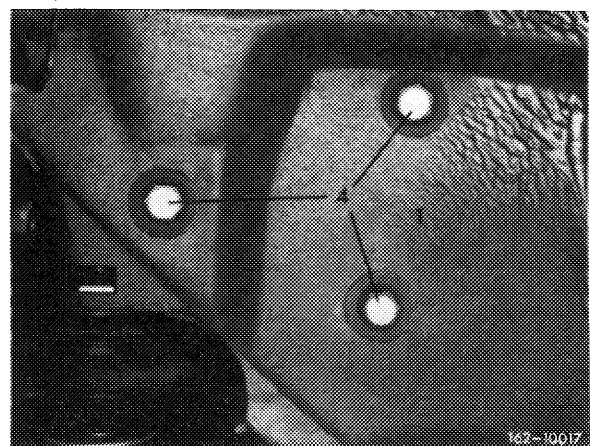

## Installation

**Note:** When the steering is renewed, make sure that only the type of steering may be installed which is marked with the code number "1" on closing cover for control valve.

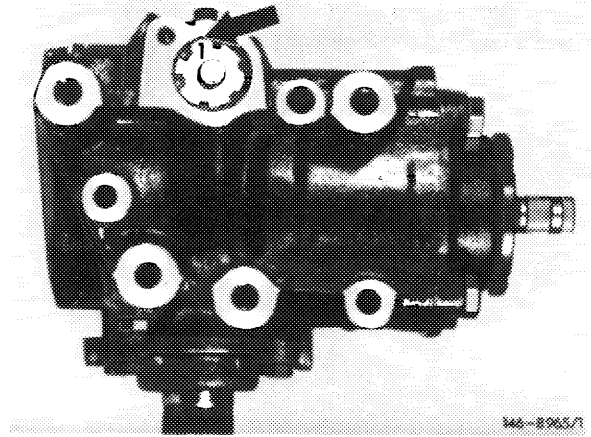

Install only steering identified with an "S" into model 107.026. This steering is provided with an additional stop to prevent pitman arm from resting against exhaust pipe when in steering lock position.

This steering is installed in all lefthand steering models starting spring 1979.

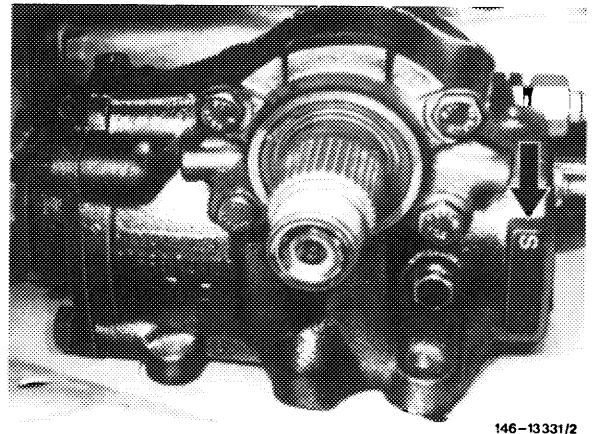

Upon repairs following an accident, when one of the side members or the front end have been straightened or replaced, or when the jacket tube has been removed, check alignment between steering shaft and steering worm. For this purpose, install steering and complete jacket tube **without steering coupling**. A vertical and lateral offset between steering shaft and steering worm of 2 mm is permitted. Alignment can be corrected by displacing jacket tube on cross member or cover plate on front end. Pay attention to perfect location of steering lock cap in cutout of instrument panel.

15 Prior to installation, check steering coupling for wear and recondition or renew, then attach steering coupling to steering shaft.

16 Turn steering to center position. For this purpose, unscrew closing plug from steering housing. Turn steering worm (3) until the center point in power piston (5) is accurately under threaded bore.

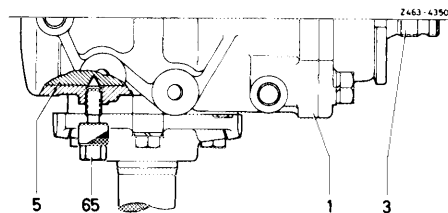

17 Screw center-position check screw (060) into steering housing and locate power piston.

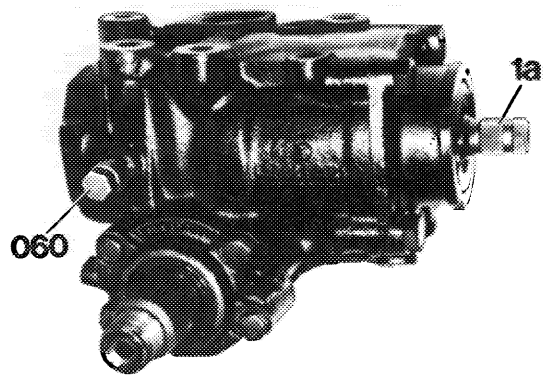

146-11347

18 Attach steering with **three new** locking screws (4) to side member of frame floor. Tightening torque 70–80 Nm (7–8 kpm).

**Attention!**

Always renew locking screws on principle.

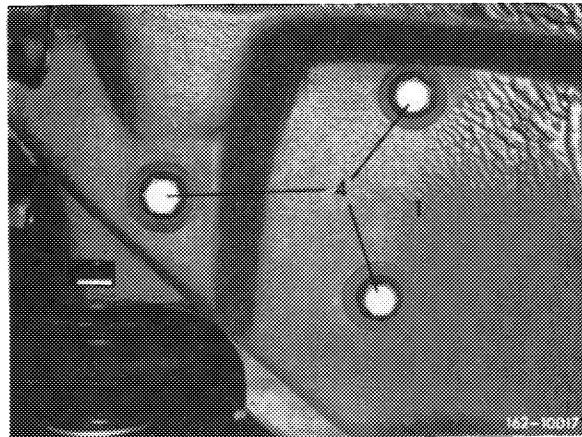

146-10017

19 Turn steering shaft until resetting cam for combination switch is in center of cutout in jacket tube and marking (2a) is pointing upwards. Then introduce steering coupling into splining of steering worm.

**Note:** The steering shaft should not move axially when steering coupling is inserted into steering worm.

20 Attach bearing body (12) to jacket tube. Install combination switch (10).

21 Install steering wheel (46–610).

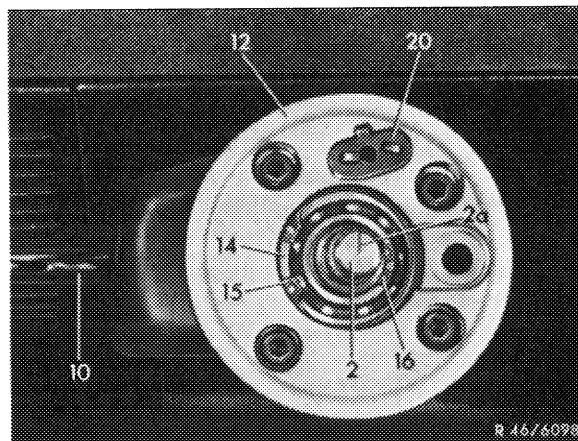

R 46/6098

**Note:** On vehicles with jacket tube 1st version the longitudinal adjustment of the steering shaft can be checked through bore in jacket tube. For this purpose, insert assembly pin (25) into check bore of steering shaft.

In jacket tube 2nd version installed starting end of 1977 the control bore in steering shaft is no longer in place.

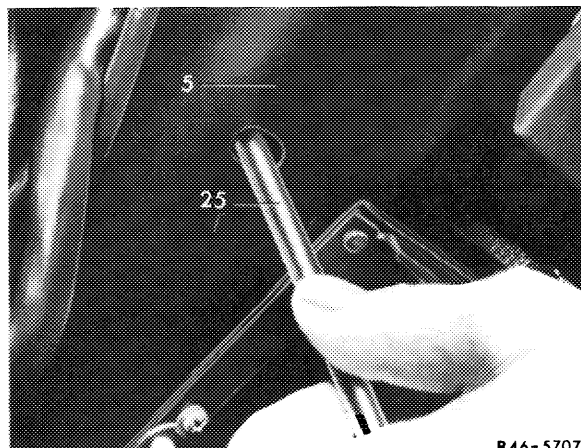

R 46-5707

**Note:** The assembly pin is self-made according to specified dimensions.

22 Unscrew center-position check screw, screw closing plug into steering housing together with a new copper sealing ring. Remove assembly pin from steering shaft.

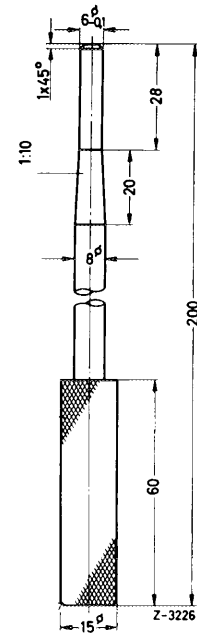

23 Screw hex. socket screw (13) into lower flange of steering coupling (12) and tighten. Tightening torque 25 Nm (2.5 kpm) – reference value.

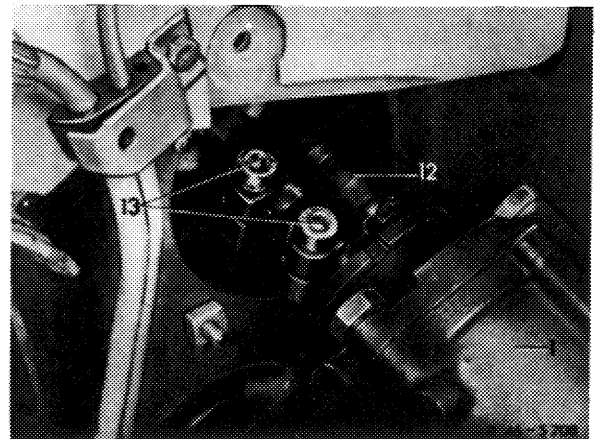

24 Slip pitman arm on splining of pitman shaft, while paying attention to code number and markings (arrow) on lever and on pitman shaft.

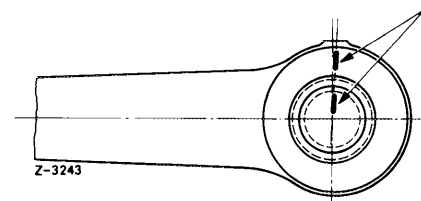

**Note:** On model 107.026 install only the sickle-shaped pitman arm(3) part no. 107 463 16 01 (code number 0716). This arm replaces simultaneously the pitman arms, part. no. 107 463 10 01 (code number 0710) and 107 463 12 01 (code number 0712) valid for the other lefthand steering models.  
The pitman arm 107 463 13 01 (code number 0713) is valid for all righthand steering models.

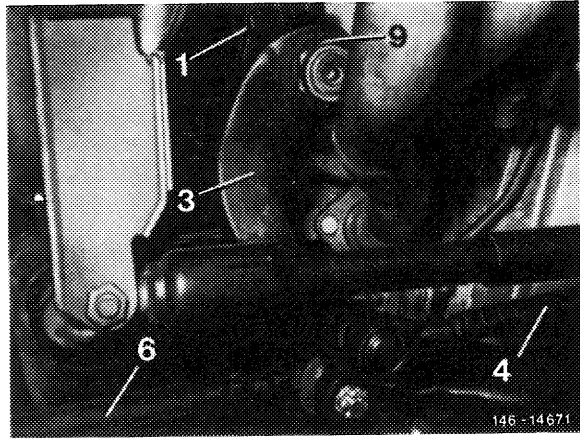

25 Attach pitman arm (24) with a new self-locking hex. nut. Tighten hex. nut to 160–200 Nm (16–20 kpm).

**Attention!**  
Be sure to renew self-locking hex. nut on principle.

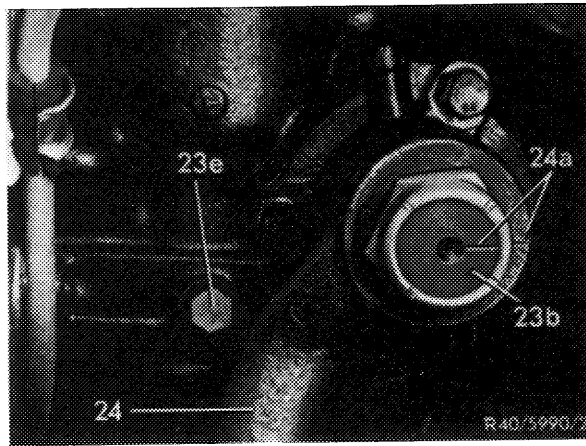

26 Check rubber sleeve (2) on joint of track rod (11). If the sleeve is damaged, check joint for wear and replace, if required (46–540).

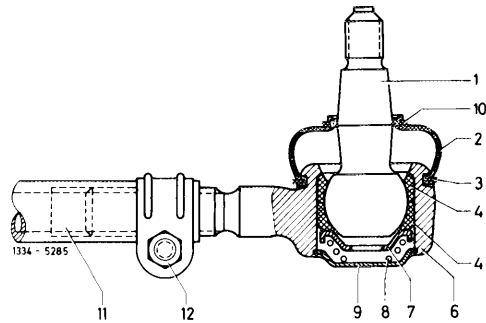

27 On drag link 1st version, check joint of drag link for wear and replace drag link, if required.

Place sealing ring (3) and plastic cover (1) on ball joint.

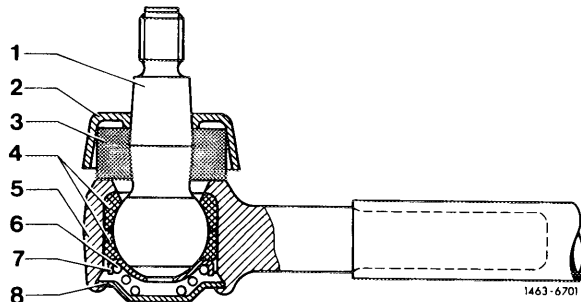



28 On drag link 2nd version, check rubber sleeve (2) on joint. If sleeve is damaged, check joint for wear and replace drag link, if required (46–550).

29 Attach track rod and drag link to pitman arm, insert cotter pins into castle nuts. Tightening torque 35 Nm (3.5 kpm) – reference value.

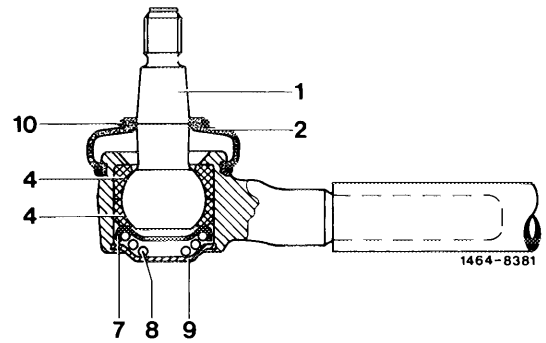

30 Remove blind plug. Connect high-pressure expanding hose and connecting pipe for return flow hose.

**Attention!**

Pay attention to perfect installation of hose. Even minor chafing marks may result in early oil losses and consequently in a loss of hydraulic support.

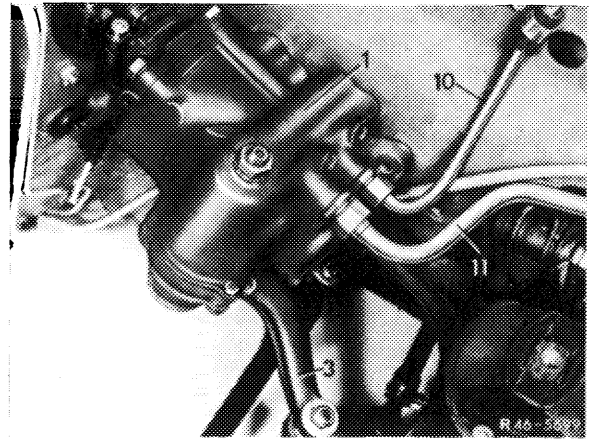

**Note:** On vehicles with 8-cylinder engine the return line (11) has been moved to frame side member for reasons of available space.

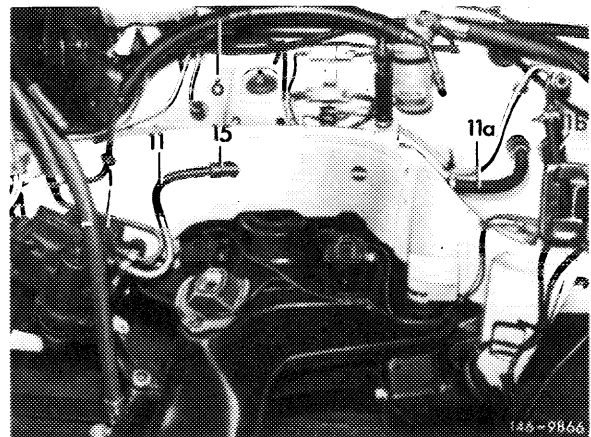

On vehicle engines 110 with increased output (production starting April 1978) the high-pressure expanding hose including rubber grommet is attached in holder (31).

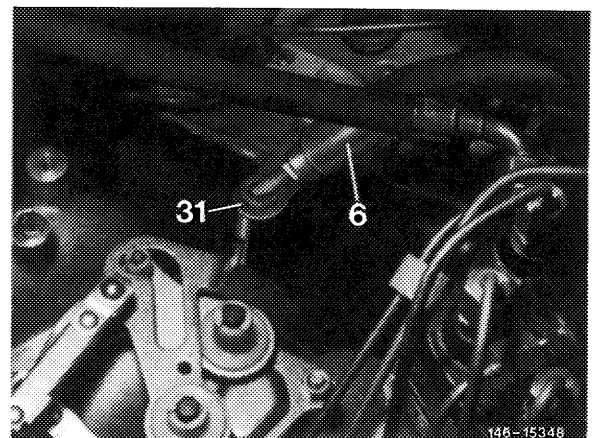

31 Install exhaust system on vehicles with 8-cylinder engine.

32 Fill supply tank of power steering pump with specified oil grade (refer to specifications for service products).

33 Run engine and turn steering several times to the left and to the right while adding oil.

**Note:** Steering is self-venting.

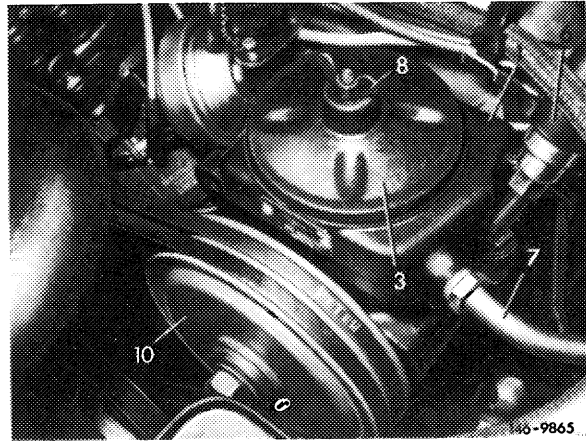

34 Turn steering completely to the left and to the right while checking whether steering knuckle arm (8) rests each time against stop (16) of lower control arm.

35 Check wheel adjusting values on front axle (40–320).

