

## 46–620 Removal and installation of jacket tube

### Data

Length of jacket tube "a"

604–1

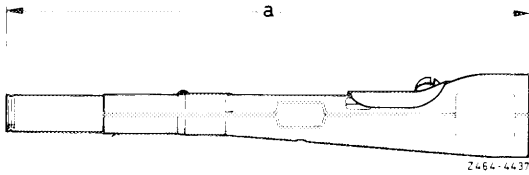

### Tightening torques

		Nm	(kpm)
Hex. nut or countersunk screw for fastening steering wheel	M 14 x 1.5	50	(5)
	M 16 x 1.5, M 18 x 1.5	80	(8)
Hex. socket screw to steering coupling		25	(2.5)
Hex. screws to cross member		25	(2.5)

### Self-made tool

Assembly pin for steering shaft

refer to illustration item 11, note

### Removal

- 1 Disconnect cable on battery.
- 2 Remove steering wheel (46–610).
- 3 Unscrew hex. socket screw (13) from steering coupling (12) and remove instrument cluster (54–310).
- 4 Remove steering lock (46–640).
- 5 Remove cover from under instrument panel and air duct.
- 6 Loosen plug connection for cable harness of combination switch.
- 7 Unscrew hex. screws for fastening cover plate to front end.

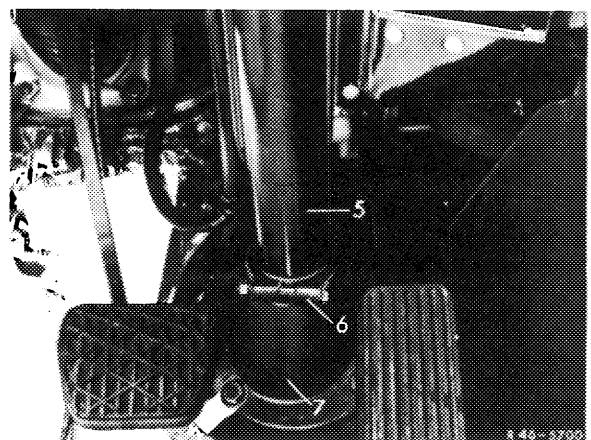
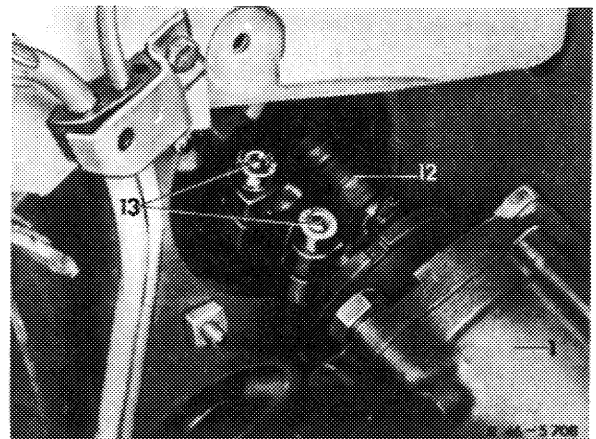

8 Unscrew both hex. bolts (2) for attaching jacket tube to cross member (1).

9 Remove jacket tube.

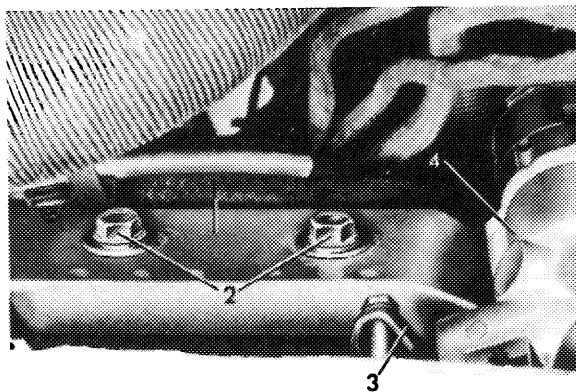

R46-5642

### Installation

If the jacket tube **has been crushed by an accident**, **replace tube**, since it can no longer be returned to its specified position.

10 Loosen clamping screw on fastening clamp (6).

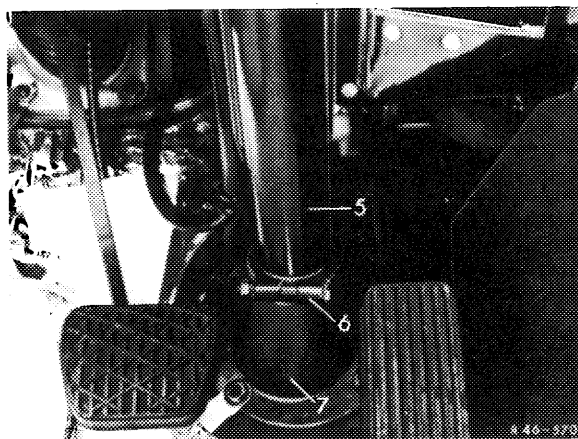

R46-5720

11 Locate steering spindle with assembly pin (25) through bore in jacket tube (5).

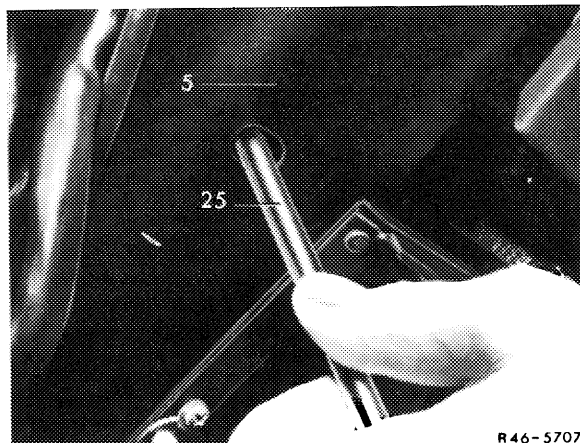

R46-5707

**Note:** Be sure to locate steering spindle to prevent displacement of spindle during installation of jacket tube.

The assembly pin is self-made according to specified dimensions.

The steering shaft 2nd version (for steering wheel with larger hub dia.) has no check bore.

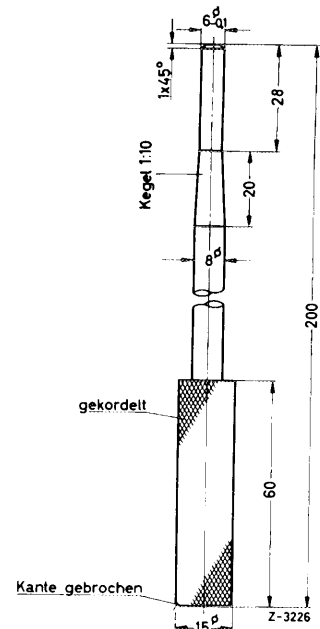

12 Check whether rubber sleeve (8) for sealing steering shaft (2) is correctly located in jacket tube (5).

13 Insert jacket tube (5) into front end and cross member, making sure that the gasket (9) is correctly seated on cover plate (7) and is inserted into steering coupling (12) together with steering shaft (2).

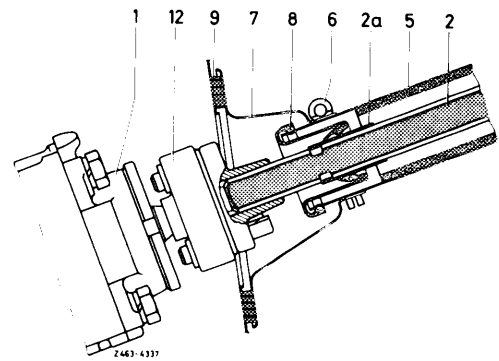

- |                   |                      |
|-------------------|----------------------|
| 1 Steering        | 7 Cover plate        |
| 2 Steering shaft  | 8 Rubber sleeve      |
| 2a Sealing ring   | 9 Gasket             |
| 5 Jacket tube     | 12 Steering coupling |
| 6 Fastening clamp |                      |

14 Screw jacket tube (5) to cross member (1) with the two hex. screws (2), but do not yet tighten screws.

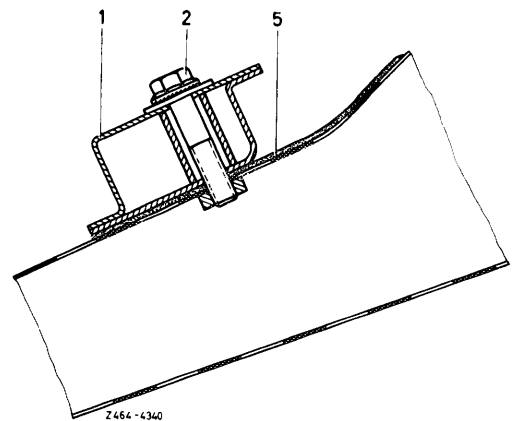

15 Attach cover plate to front end, then tighten hex. screws on cross member and clamping screw on fastening clamp.

16 Connect plug connection of cable harness to each other.

17 Install steering lock (46-640) and check for function.

18 Install instrument cluster (54-310).

19 Screw upper hex. socket screw into steering coupling and tighten. Tightening torque 25 Nm (2.5 kpm) – reference value.

20 Install steering wheel (46–610).

21 During test drive, check position of steering wheel in straight-ahead position of wheels. If steering wheel position while driving straight-ahead is not in alignment with front wheels, check toe-in and correct, if required. If steering wheel position then still requires a correction, the steering wheel can be displaced in splining to the left or right (max. 2 teeth).