

77—180 Removal and installation of holder with motor and gear unit

If the Drive Cable Control Can be Removed

Removal

- 1 Remove drive cable control (77—140).
- 2 Separate outlet pipe (35) from gear unit.
- 3 Loosen fastening screws (40) of holder (39).
- 4 Disconnect electric connection.
- 5 Separate holder with motor and gear unit from drive cable tube and remove.

Installation

- 6 For installation proceed vice versa.

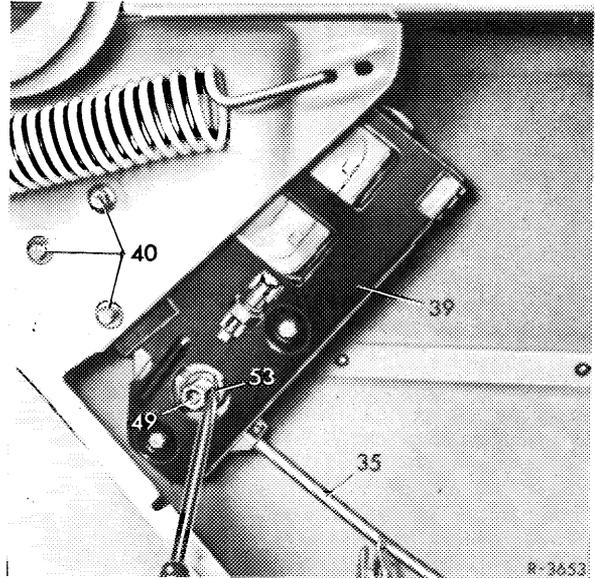

(shown on Model 114/115)

If the Drive Cable Control Cannot be Removed

Removal

Note: First try to remove drive cable control as described in Job No. 77—140. If this is impossible, disassemble drive gear.

- 1 Loosen lock (53) of counter nut (49) on gear unit and unscrew counter nut.
- 2 Remove holder (39).
- 3 Screw fastening screws (43) out of gear unit cover (42).

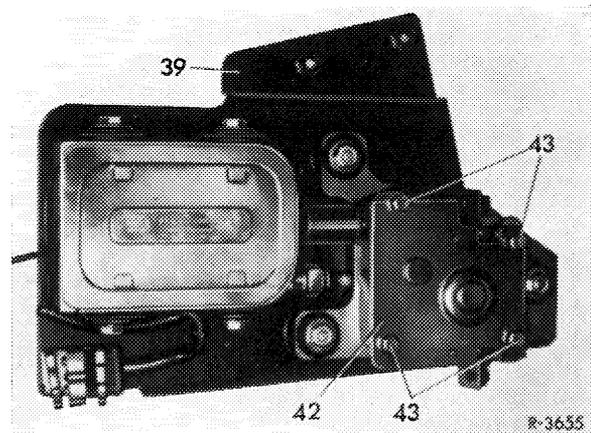

4 Remove gear unit cover (42) and take off large gear wheel (44) including drive shaft (45).

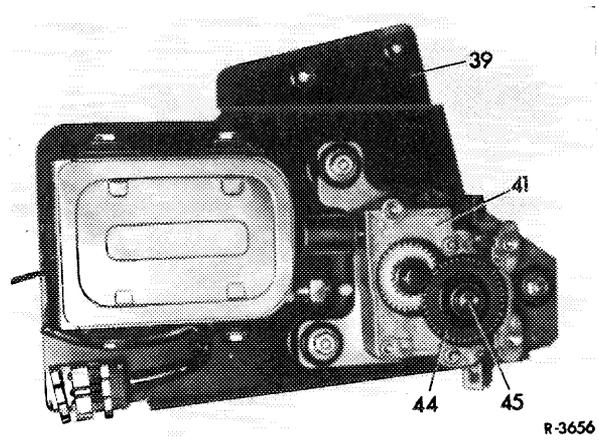

5 Disconnect drive cable tube and outlet pipe (35) from gear unit.

6 Remove drive cable control (27) (77—140).

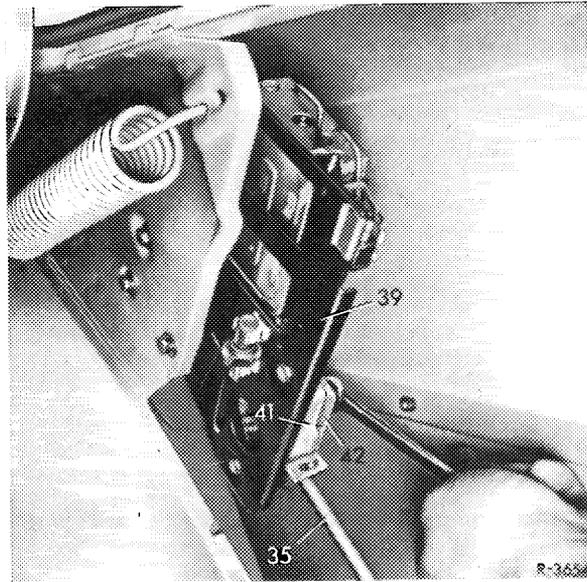

Installation

7 Assemble gear unit.

8 Install holder with motor and gear unit.

9 Install drive cable control.

Attention! At end of assembly jobs, the slip coupling on gear unit must be readjusted (77—190).