

Color code of vacuum lines for central interlock

Vacuum line	Color code	
	1st version	2nd version
Suction line to vacuum switch (27)	yellow	yellow
Interlocking line (25)	white	yellow-red
Unlocking line (26)	black	yellow-green

Removal

- 1 Remove door lining.
- 2 Remove safety clip (39) of pull rod (40) and disconnect pull rod.
- 3 Unscrew oval head screws from vacuum switch (7).

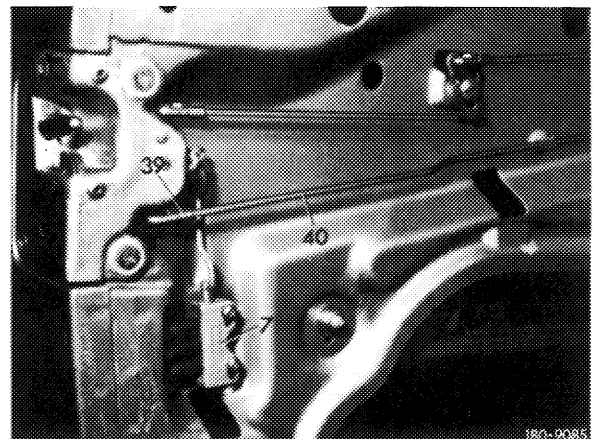

- 4 Pull connections (17) together with interlocking line (25) at bottom, unlocking line (26) at top and suction line (27) in center from vacuum switch (7).
- 5 Disconnect vacuum switch on door lock.

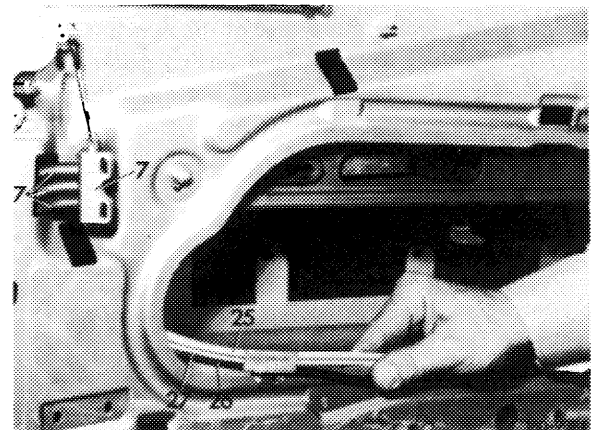

Attention!

Since June 1972, the suction line (27) of lefthand driver's door is provided with an additional check valve. Since August 1976, this check valve is replaced by a modified version (white-black).

In contrast to the former version, the additional check valve of the new version may not be used at any other point of vacuum system, since otherwise the function of the system is no longer assured.

Installation

- 6 Connect vacuum switch to door lock.
- 7 Slip connections (17) with interlocking line (25) at bottom, unlocking line (26) at top and suction line (27) in center on vacuum switch (7).
- 8 Attach vacuum switch (7) with oval head screws in such a manner that switch will be hard to move within its oblong holes.
- 9 Attach pull rod (40) and slip-on safety clip (39).
- 10 Run engine for a short moment, insert door key into lock and open and close.
- 11 Adjust vacuum switch.

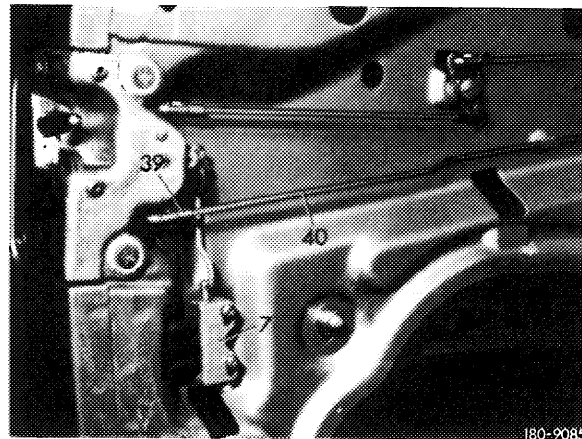
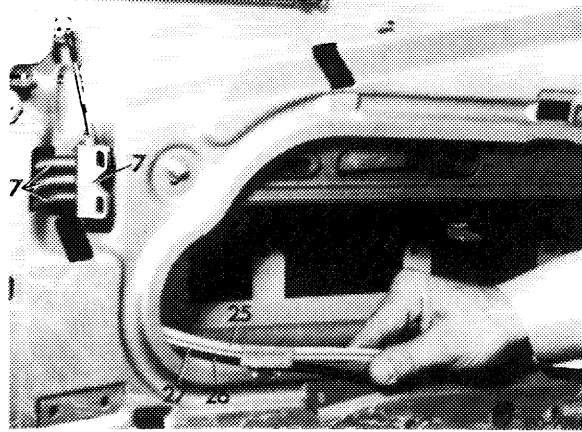

Version A (no longer installed):

Set vacuum switch of light alloy in such a manner that in locked condition the outer edge of the switch is in alignment with center of outer adjusting groove or in unlocked condition with center of inner adjusting groove.

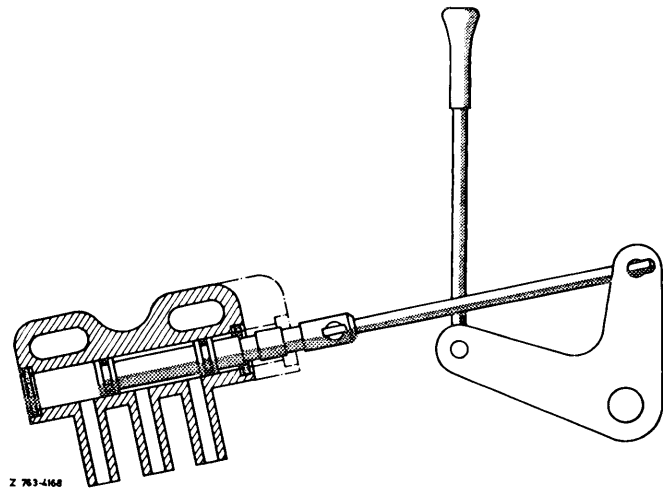

Version B (no longer installed):

Adjust plastic vacuum switch in such a manner that in locked condition the outer edge of the switch is in alignment with outer adjusting groove or in unlocked condition with inner adjusting groove.

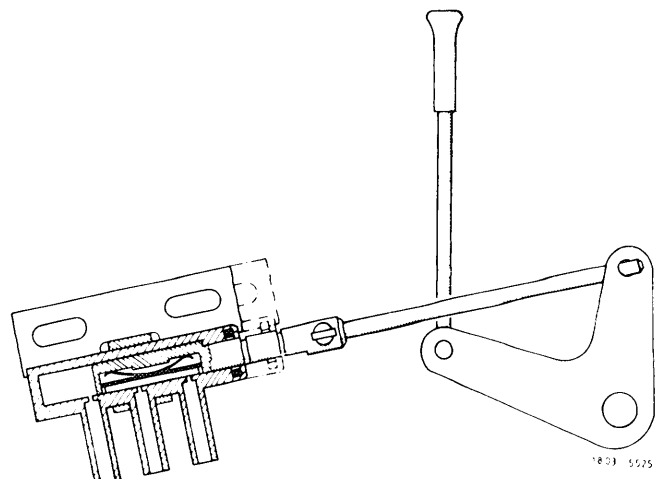

Version C (no longer installed):

Adjust plastic vacuum switch in such a manner that in locked condition the outer edge of the switch is in alignment with center of outer adjusting groove (refer to arrow a), or in unlocked condition with center of inner adjusting groove (refer to arrow b).

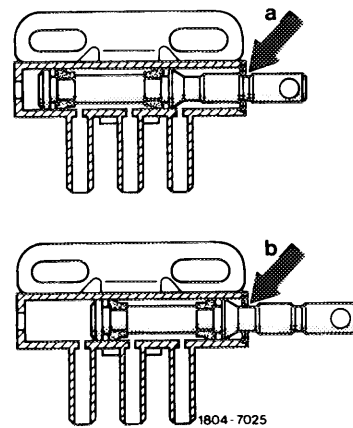

Version D:

Adjust plastic vacuum switch in such a manner that the outer edge of the switch in locked condition is in alignment with center of adjusting groove (refer to arrow a). This plastic vacuum switch replaced all former versions.

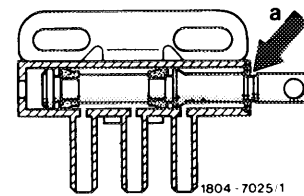

Attention!

If the adjusting range of version D is inadequate, extend onlong holes (slots) in holder by filing.

Note: The central locking system should already respond before the key is in its respective end position.

- 12 Tighten oval head screws of vacuum switch.
- 13 Install door lining.

