

B. Delco refrigerant compressor (engines 116 and 117)

Data

Designation Electromagnetic shutoff clutch 12 V, Frigidaire 5 5/8 inch or 5 inch

Power input cold 3.0 amps warm 2.5 amps

Tightening torque	Nm	(kpm)
Flange nut to shaft	20	(2.0)

Special tools

Pin spanner for counterholding spring plate



116 589 10 07 00

Pulling tool for spring plate

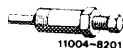

000 589 07 35 00

Installing tool for spring plate

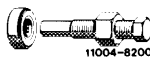

000 589 49 43 00

Puller



000 589 88 33 00

Thrust piece for puller



116 589 05 63 00

Mandrel for pulley



115 589 02 35 02

Remover and installer for slip ring

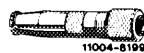

000 589 21 61 00

Remover and installer for shaft sealing ring

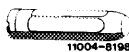

000 589 65 63 00

Holding device for refrigerant compressor

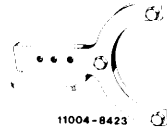

109 589 00 31 00

**Conventional tools**

Slip gauges 0.05–1.00 m

order no. 2147

Pliers for internal lock

order no. 1846b-2

e.g. made by Hazet  
5630 Remscheid 1

Pliers for external lock

order no. 1846d-2

**Note**

Removal and installation of spring plate with pulley and clutch coupler, as well as of shaft seal, can be performed **without removal** of refrigerant compressor and refrigerant compressor carrier.

**a) Spring plate**

**Removal**

1 If the refrigerant compressor is removed, clamp refrigerant compressor with refrigerant compressor carrier into vise, without refrigerant compressor carrier into holding fixture for refrigerant compressor.

2 Prevent rotation of spring plate (4) by means of holding tool (2), unscrew collar nut from shaft using 14 mm socket.

Unscrewing collar nut from shaft end

- 1 Refrigerant compressor
- 2 Holding tool
- 3 Socket
- 4 Spring plate

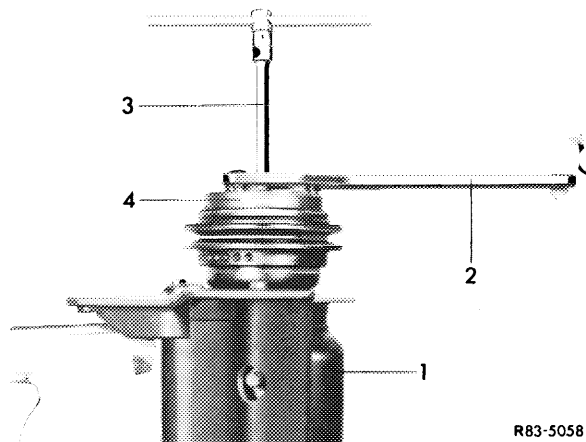

R83-5058

3 Screw remover (2) into hub. Hold tool in place with wrench and tighten central screw.

4 Remove Woodruff key from shaft.

Removing spring plate

- 1 Refrigerant compressor
- 2 Remover
- 3 Spring plate

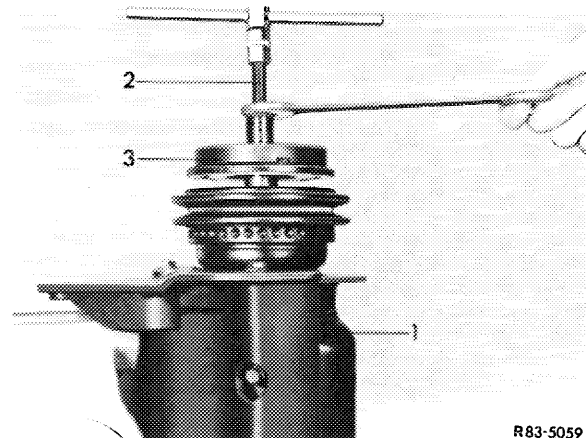

R83-5059

## Installation

- 5 Insert Woodruff key into shaft.
- 6 Clean friction surface of spring plate and pulley.
- 7 Place spring plate on shaft so that key and key groove are in alignment.

### Attention!

To protect parts inside compressor against damage, do not knock on or against spring plate or shaft.

- 8 Place spacer (2) on spring plate (1). Insert installer (3) through spacer (2) and screw installer (3) to shaft end.

- 9 Hold hexagon of tool in position and screw-in center screw by several turns to press spring plate in part on shaft.

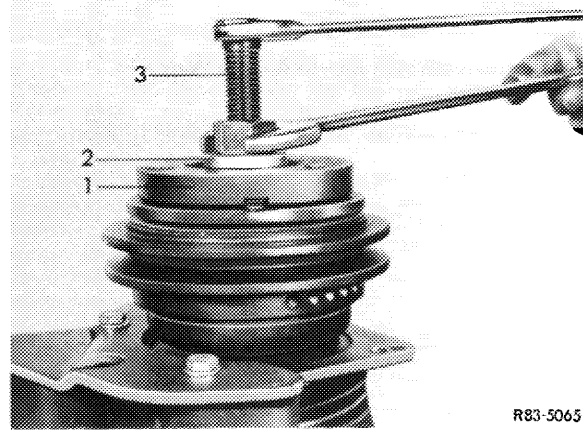

- 10 Remove installer (3) and spacer (2), check key and key groove for alignment. If both are correctly aligned, mount installer again and continue pressing spring plate (1) on shaft until a distance of approx. 1 mm to 1.5 mm is obtained between the friction surfaces of the pulley and the spring plate.

- 11 Remove installer (3) and spacer (2).

### Sectional view of shaft seal and seat of seal

- |                  |                      |
|------------------|----------------------|
| 1 Shaft          | 8 Felt ring          |
| 2 Hub            | 9 Locking ring       |
| 3 Collar nut     | 10 Ceramic ring      |
| 4 Locking ring   | 11 O-ring            |
| 5 Holding ring   | 12 Shaft seal        |
| 6 Spacing washer | 13 Front head member |
| 7 Woodruff key   |                      |

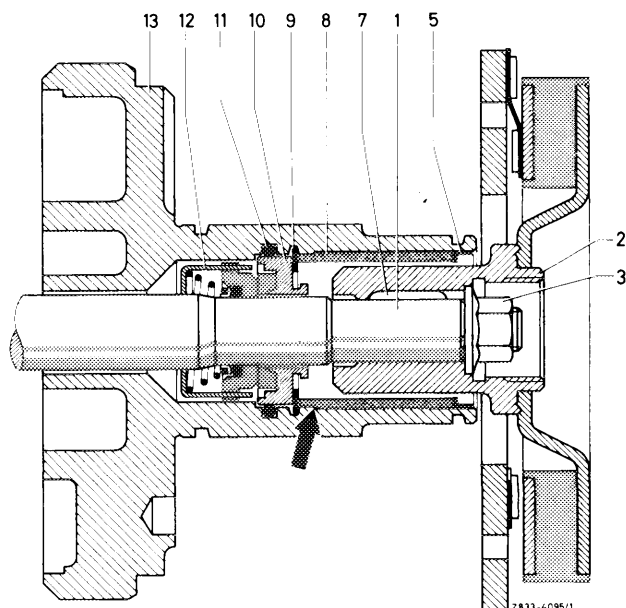

12 Screw on new collar nut. Hold spring plate in place with holding tool (2) and tighten counternut. Distance between the two friction surfaces of the pulley and the spring plate should now amount to approx. 0.5 to 1.5 mm.

Checking distance between spring plate and pulley

1 Spring plate      2 Pulley

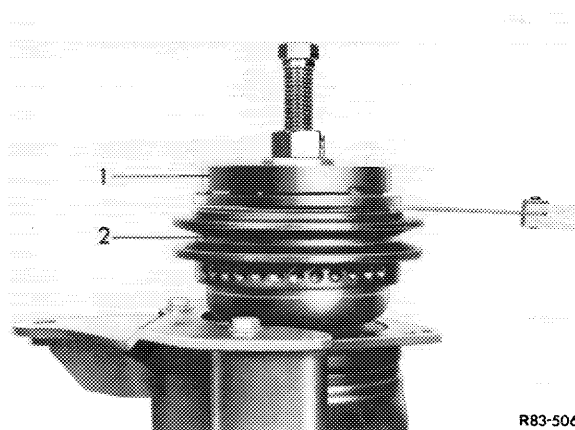

R83-5066

## b) Pulley

### Removal

- 1 Remove spring plate (section a item 1 to 5).
- 2 Remove locking ring (2) and holding ring (5).

Remove locking ring for pulley

1 Pulley      2 Locking ring

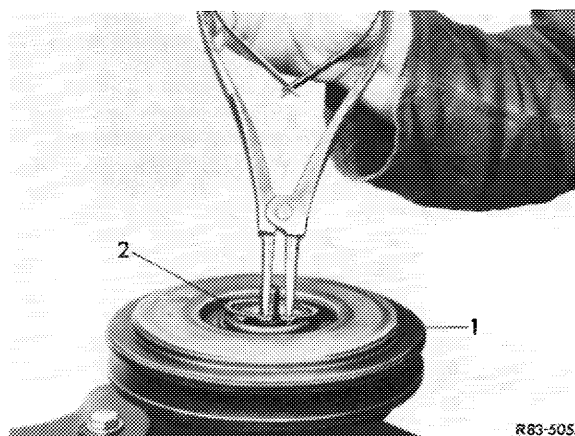

R83-5055

3 Insert guide piece (2) into bore in head member of compressor.

4 Pull-off pulley (1) with puller (3).

Removing pulley

1 Pulley      2 Guide piece

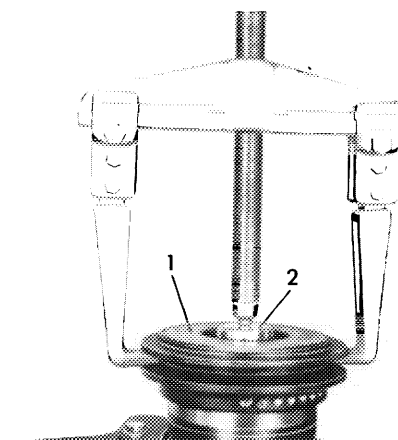

R83-5056

### Installation

5 If the same pulley is reinstalled, clean friction surface of pulley. If friction surface is damaged, e.g. by overheating, replace pulley together with spring plate.

6 Knock pulley (1) with the assistance of punch (2) onto guide journal of refrigerant compressor. Position punch in such a manner that the impact force is guided against inner bearing race and the bearing itself is not damaged.

Installation of pulley  
1 Pulley      2 Punch

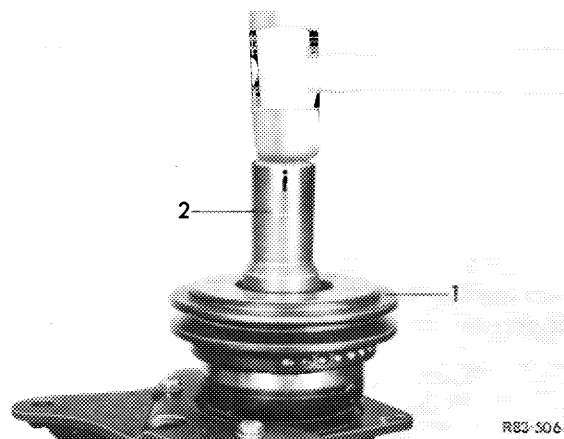

7 Check pulley for unobstructed operation. Then insert locking ring (2) with flat side down.

8 Install spring plate (section a).

Removing locking ring for pulley  
1 Pulley      2 Locking ring

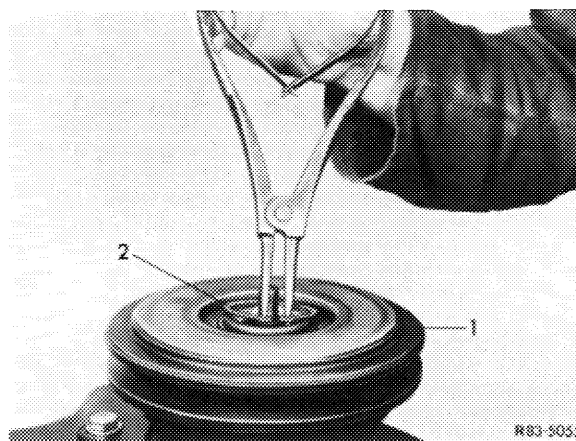

### c) Clutch coupler

#### Removal

1 Remove spring plate and pulley (section a and b).

2 Mark position of electric connections on coupler housing on front head member of refrigerant compressor.

3 Remove locking ring (3).

4 Lift clutch coupler (2) from refrigerant compressor (1).

Removing and installing clutch coupler  
1 Refrigerant compressor  
2 Clutch coupler  
3 Locking ring

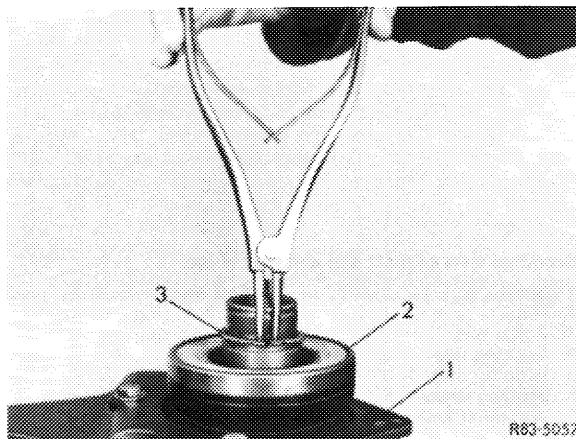

## Installation

5 Insert clutch coupler (2) on front head member of refrigerant compressor in such a manner that the electrical connections are in alignment with the markings previously made on refrigerant compressor.

6 Align guide pins at bottom on coupler housing with holes in front head member of refrigerant compressor.

7 Install locking ring (3) with flat side of ring in direction of coupler.

8 Install pulley and spring plate (section a and b).

### d) Shaft seal of refrigerant compressor

#### Removal

1 Remove spring plate (section a).

**Note:** Removal of pulley and clutch coupler is not necessary for removal and installation of shaft seal.

2 Remove holding ring (5) and felt ring (8).

Sectional view of shaft seal and seat of seal

- |                  |                      |
|------------------|----------------------|
| 1 Shaft          | 8 Felt ring          |
| 2 Hub            | 9 Locking ring       |
| 3 Collar nut     | 10 Ceramic ring      |
| 4 Locking ring   | 11 O-ring            |
| 5 Holding ring   | 12 Shaft seal        |
| 6 Spacing washer | 13 Front head member |
| 7 Woodruff key   |                      |

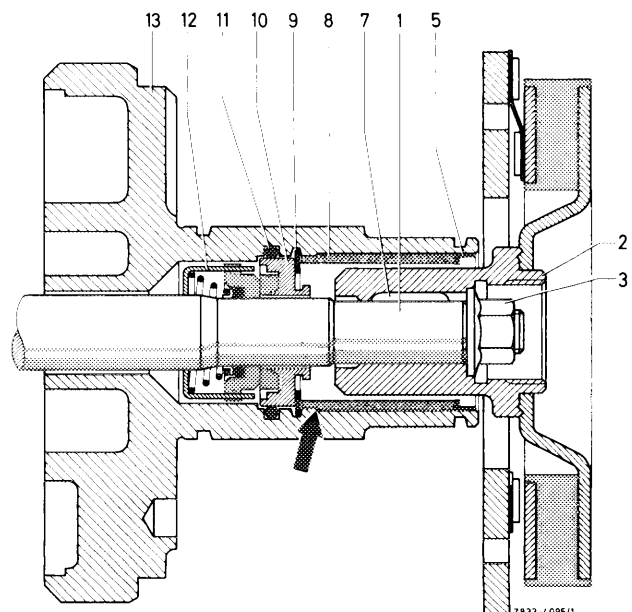

**Note:** Puller is self-made from 2.5 mm dia. brass wire.

Removing holding ring  
5 Holding ring

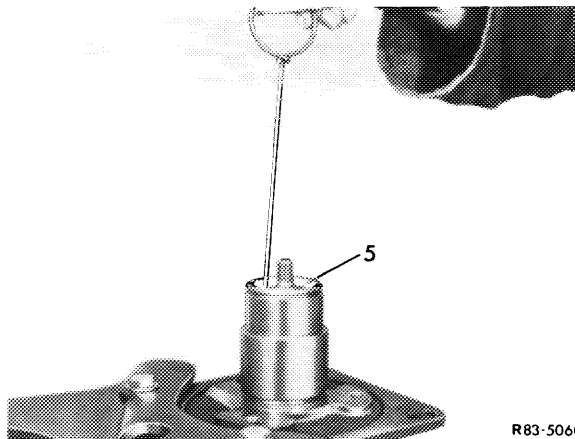

R83-5060

- 3 Remove locking ring (9) for shaft seal.
- 4 Remove slip ring (3 or 9) with assistance of remover and installer (2).

Removing locking ring for shaft seal  
9 Locking ring

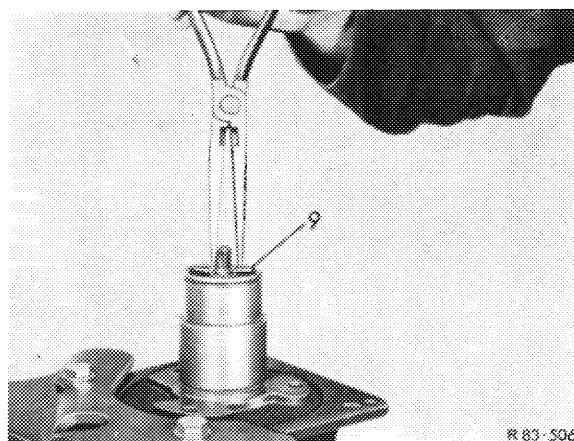

R 83-5061

Removing ceramic slip ring  
1 Refrigerant compressor  
2 Remover and installer  
3 Slip ring

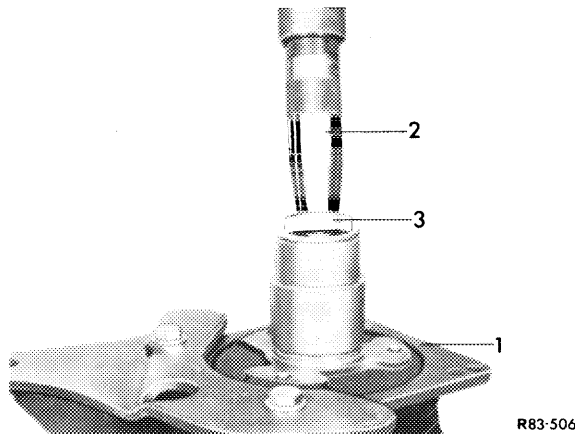

R83-5062

- 5 Remove shaft seal (2 or 11) with the assistance of tool (3). For this purpose, push on tool, turn tool clockwise to grip the lugs of the shaft seal with the locking tongues on tool. Remove complete shaft seal by pulling straight from shaft.

Removing shaft seal  
1 Refrigerant compressor  
2 Shaft seal  
3 Remover and installer

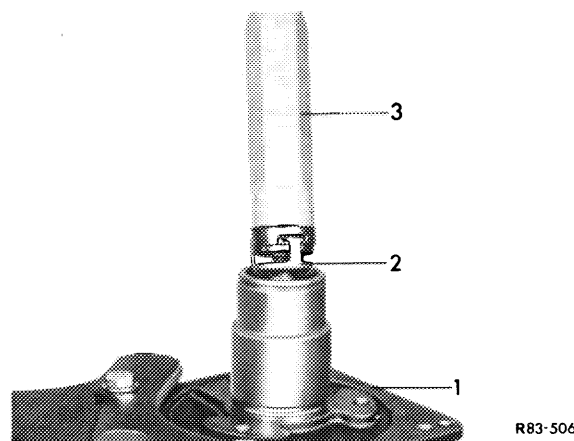

R83-5063

6 Remove O-ring (11) from inside bore in front head member of refrigerant compressor. This can be done by means of a piece of wire bent into a hook.

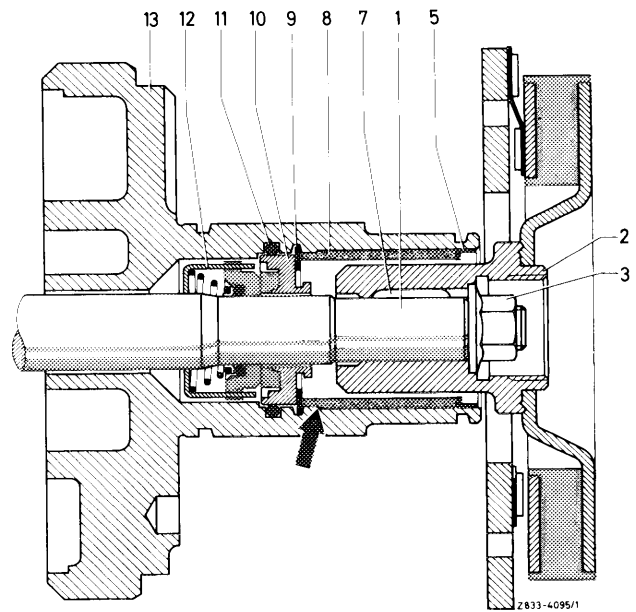

Sectional view of shaft seal and seat of seal

- |                  |                      |
|------------------|----------------------|
| 1 Shaft          | 8 Felt ring          |
| 2 Hub            | 9 Locking ring       |
| 3 Collar nut     | 10 Ceramic ring      |
| 4 Locking ring   | 11 O-Ring            |
| 5 Holding ring   | 12 Shaft seal        |
| 6 Spacing washer | 13 Front head member |
| 7 Woodruff key   |                      |

### Installation

7 Check whether parts of old seal are in bore of front head member. Clean bore prior to inserting a new seal.

8 Insert new O-ring (11) into groove of bore in head member (13), making sure that the sealing ring is inserted in lower groove.

9 Provide shaft sealing ring (11) prior to installation with cold-flowing oil to prevent any damage to seal during insertion.

10 Insert shaft seal (2 or 12) into tool (3) and slip on shaft in compressor. Keep turning tool clockwise until shaft seal engages in shaft. Only then turn tool counterclockwise for disconnection and removal from lugs of shaft seal.

- Installing shaft seal
- |                          |
|--------------------------|
| 1 Refrigerant compressor |
| 2 Shaft seal             |
| 3 Remover and installer  |

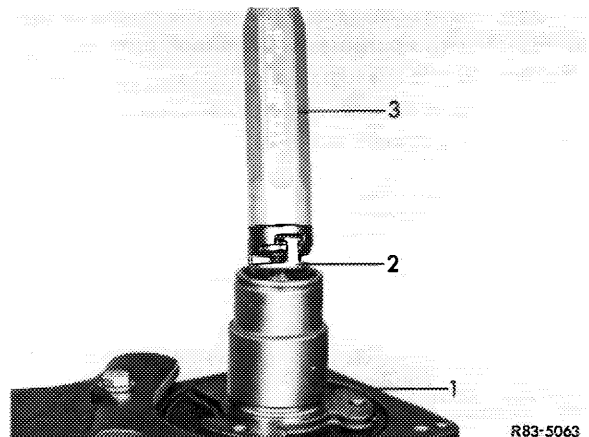



11 Introduce slip ring (3 or 10) with assistance of tool (2) into bore of front head member until ring touches shaft seal. Make sure that the O-ring (11) is not pushed out of groove.

**Installation of ceramic slip ring**

- 1 Refrigerant compressor
- 2 Remover and installer
- 3 Slip ring

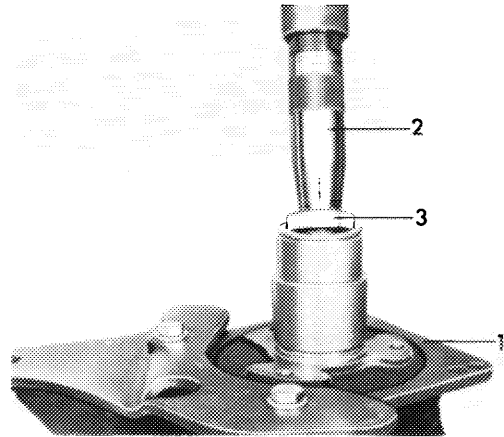

R83-5062

**Attention!**

Protect sealing surface of slip ring against any damage, such as scratches.

12 Introduce locking ring (9) with flat side down into bore until locking ring rests on slip ring. Then push against locking ring by means of locking ring pliers or a screwdriver until locking ring snaps into groove.

**Installing locking ring for shaft seal**

- 9 Locking ring

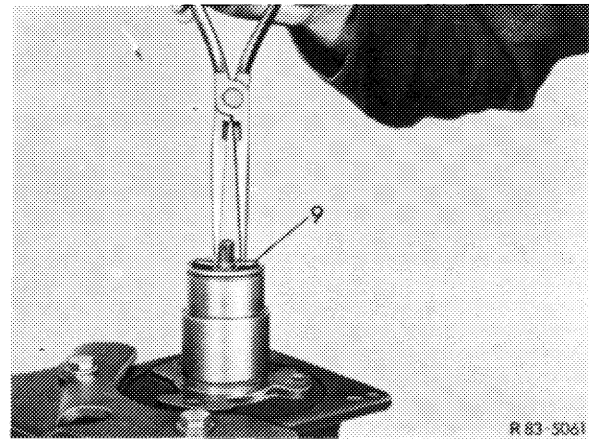

R 83-5361

**Note:** The shoulder (refer to arrow) seen from end of bore is a projection and not a groove.

13 Install spring plate as described in section a).

14 Check oil level in refrigerant compressor (83-520).

15 Check compressor for leaks (83-525).

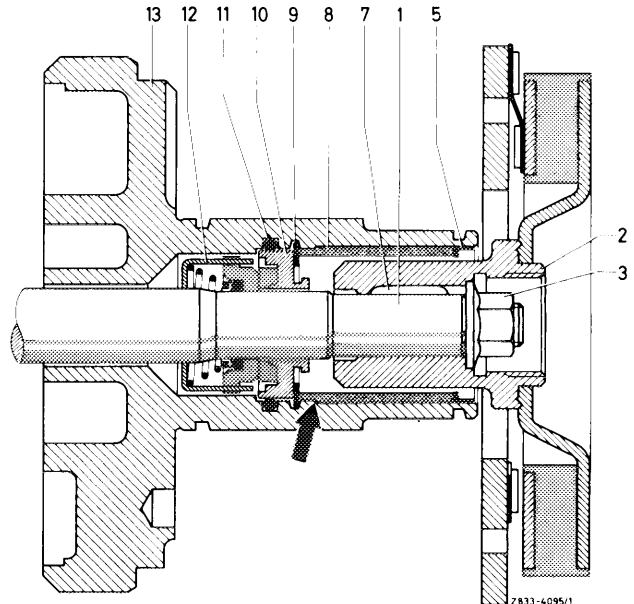

2833-4095/1