

## 03—310 Checking, renewing and tightening connecting rod bolts

### Dimensions of connecting rod bolts and connecting rod nuts

Engine	116.960 <sup>1</sup> )/961 <sup>1</sup> ) 117.960/961	116.960 <sup>2</sup> )/961 <sup>2</sup> ) 116.962/963 116.964/965 117.962/963 117.964/965 117.967/968
Part No.	116 038 04 71	116 038 05 71
Thread dia. d	M 10 x 1	
Necked-down shank dia. c when new	8.4–0.1	
Minimum necked-down shank dia. c	8.0	
a	6.6	
Dimension b	4.5	
e	5.2	4.2
Length L	58.2–58.5	49.2–49.5
Connecting rod nut height H	11	9

<sup>1</sup>) Not model year 1981 national version.  
<sup>2</sup>) Only model year 1981 national version.

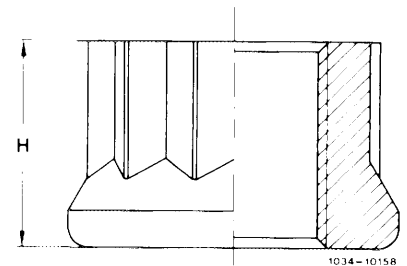
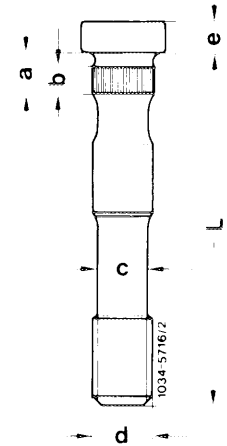

### Tightening torque

Connecting rod nuts	Initial torque	40–50 Nm
	Angle of rotation torque	90–100°

### Tool for self-fabrication

Steel plate	see Fig., item 3
-------------	------------------

## Note

Prior to assembly, lubricate connecting rod bolt threads and contact surface of nuts with engine oil.

The connecting rod bolt 116 038 04 71 is identical with the 3rd connecting rod bolt version of the cast-iron engines 116.98 and 117.98.

Drive out connecting rod bolts only if they have to be renewed.

## Checking

1 Prior to re-using connecting rod bolt measure minimum necked-down shank dia. c.

If the minimum necked-down shank dia. c is reached, renew connecting rod bolt.

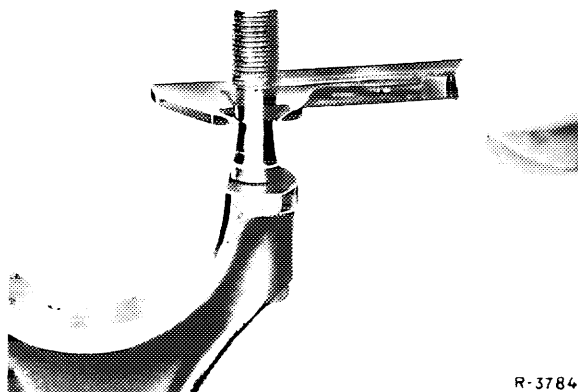

## Renewing

2 Drive out connecting rod bolts.

3 Press new connecting rod bolts into connecting rod with approx. 45 000 N or install with hammer and mandrel. To do so, place connecting rod on a ground steel plate.

Engine	116.960 <sup>1)</sup> /961 <sup>1)</sup> 117.960/961	116.960 <sup>2)</sup> /961 <sup>2)</sup> 116.962/963 117.962/963	116.964 116.965 117.964 117.965 117.967 117.968
Hole distance a	68 mm		64.6 mm
Hole b		11.5 mm	

<sup>1)</sup> Not model year 1981 national version.  
<sup>2)</sup> Only model year 1981 national version.

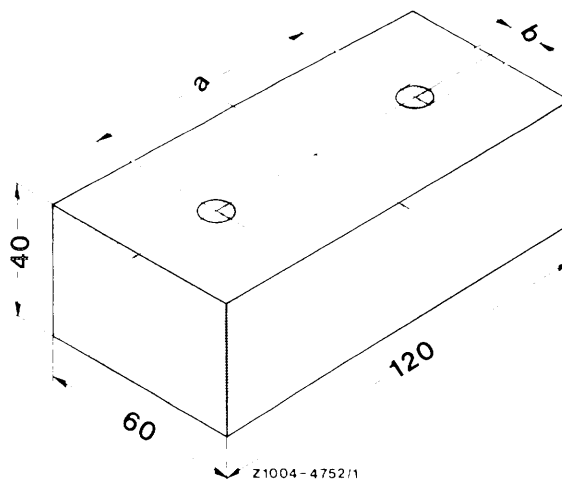

## Tightening

---

4 Lubricate contact surface of nuts and connecting rod bolt thread.

5 Tighten connecting rod nuts to 40–50 Nm initial torque and 90–100° angle of rotation torque.

### Caution!

Tighten connecting rod bolts knocked in with a **hammer** with an initial torque of 50–60 Nm followed by a 90–100° angle of rotation torque.

It is essential that this instruction is observed, failure to do so could result in the connecting rod nuts coming loose.

**Note:** If no angle of rotation wrench is available, the nut can also be turned **in one go** by the specified angle using an ordinary socket wrench. The angle should be observed as accurately as possible. **In order to prevent faults with the angular torque, do not use a torque wrench** when tightening according to angular degrees.

