

**Data**

|   |                  |
|---|------------------|
| Permissible lateral runout of ring gear         | 0.3 mm           |
| Centering collar dia. for driven plates         | 296.00–296.05 mm |
| Residual unbalance of ring gear with steel ring |                  |

A. Engines 116.960/961/962/963,  
117.960/961/962/963 with automatic  
transmission 722.3 (W 4 A 040)  
without position indicator

**Note**

When removing the transmission the ring gear remains on the engine.

The ring gear and the welded-on steel ring are balanced together.

The ring gear (20) is welded to a steel ring and bolted to the driven plates (17 and 18).

The 1.5 mm thick driven plate outer diameter is a machined fit for the centering of the ring gear.

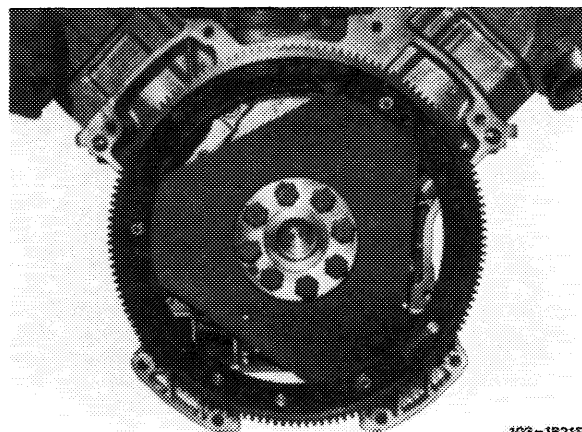

103-16215

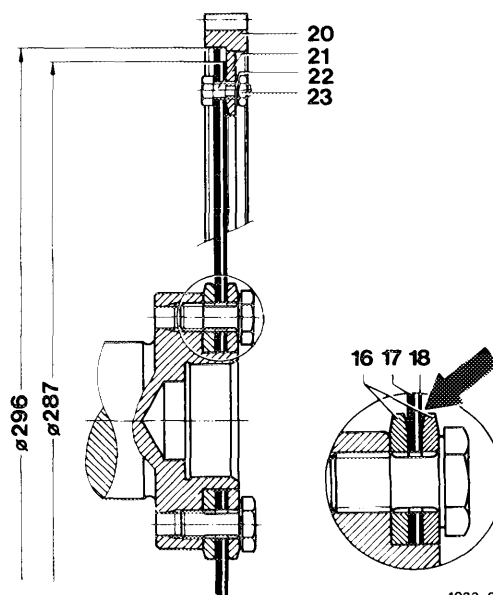

- 16 Plates 4.5 mm
- 17 Driven plate 1.5 mm, 296 mm dia.
- 18 Driven plate 1 mm, 287 mm dia.
- 20 Ring gear
- 21 Fitted bolt
- 22 Spring washer B 6
- 23 Nut M 6

1033-9075

Lighter driven plates and ring gears (version B) were installed in the period November 1982 to February 1983 and as of June 1983.

| Designation                   | Version A     | Version B     |
|-------------------------------|---------------|---------------|
| Driven plate,<br>1 mm thick   | 117 032 04 06 | 117 032 06 06 |
| Driven plate,<br>1.5 mm thick | 117 032 05 06 | 117 032 07 06 |
| Ring gear                     | 117 030 03 12 | 117 030 04 12 |

In the case of repair, the version A of the ring gear must be replaced with the version B.

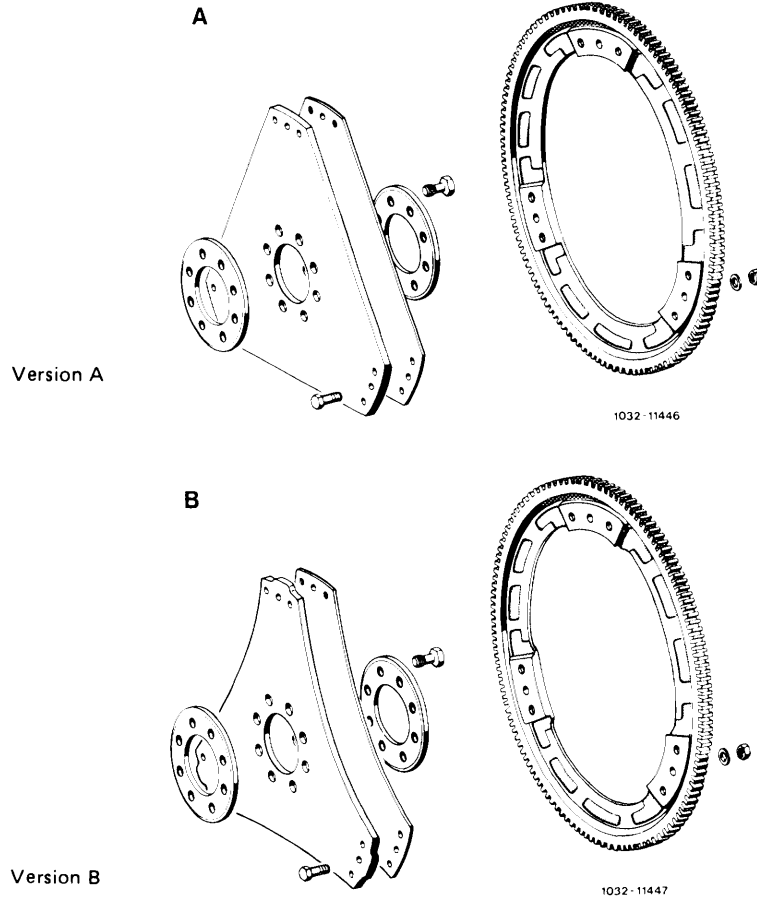

B. Engine 117.960 with automatic transmission 722.006 (W 3 B 050)

**Note**

When removing the transmission, the ring gear remains on the torque converter.

Ring gear with welded-on steel ring are balanced as a unit.

C. Engines 116.964/965, 117.964/965/967/  
968 with position indicator for ignition  
system

**Note**

When removing the transmission the ring gear  
remains on the engine.

The ring gear (20) with 4 segments for the position  
indicator of the ignition system is forged from one  
piece, balanced and bolted to the driven plates (17)  
and (18).

The 1.5 mm thick driven plate outer diameter  
is a machined fit for the centering of the ring gear.

- 16 Plates
- 17 Driven plate 1.5 mm
- 18 Driven plate 1.0 mm
- 19 Necked-down bolt
- 20 Ring gear
- 21 Bolt
- 22 Washer
- 23 Nut
- 24 Locating pin

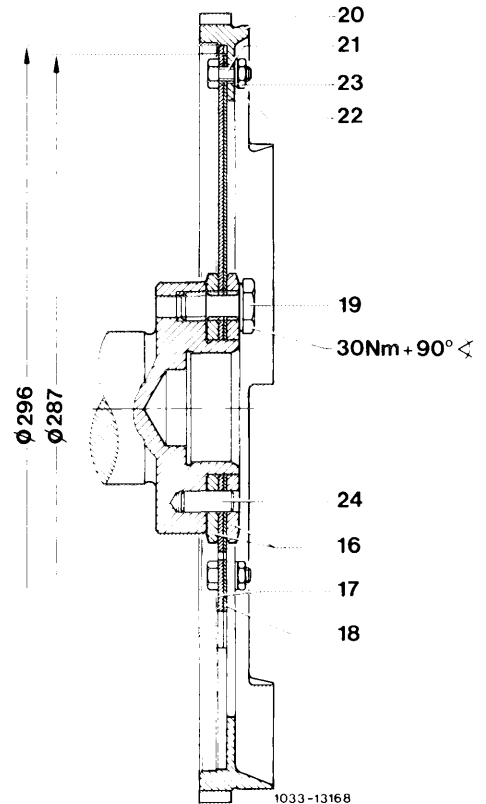

When removing the ring gear, unscrew position indi-  
cator (3) and pull out of holder (1) to avoid actuation.

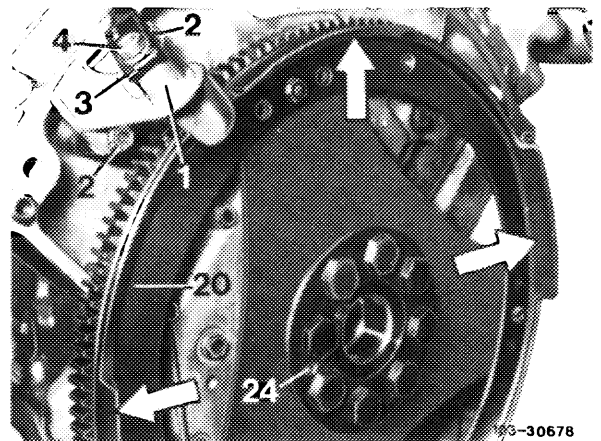

**Caution!**

The ring gear must be mounted so that the 3.5 mm  
dia. holes (arrows) in the ring gear and the driven  
plates assume the same angular position, otherwise  
a proper functioning of the ignition is not guaranteed.

