

**Mechanically controlled gasoline injection system
with air flow sensor (abbreviated designation CIS)**

A. General information

Brief designation of gasoline injection system: CIS

C = Continuously
The fuel is injected **continuously** in a finely atomized spray into the intake passage ahead of the inlet valves.

IS = Injection system drive
This injection system does **not** require to be **driven** by the engine.

Mechanical CIS requires no drive from engine.

The air aspirated by the engine is controlled by means of throttle valve and is measured with an air flow sensor installed prior to throttle valve. The fuel distributor dispenses the respective fuel quantity to the individual engine cylinders in accordance with the air volume measured.



The accurately measured fuel quantity is fed to the injection valves, from where the fuel is injected continuously and in finely atomized shape in front of the intake valves.

The mixture is adapted to operating conditions during cold start, during warm-up stage, as well as during acceleration and full load operation by means of pertinent additional equipment.

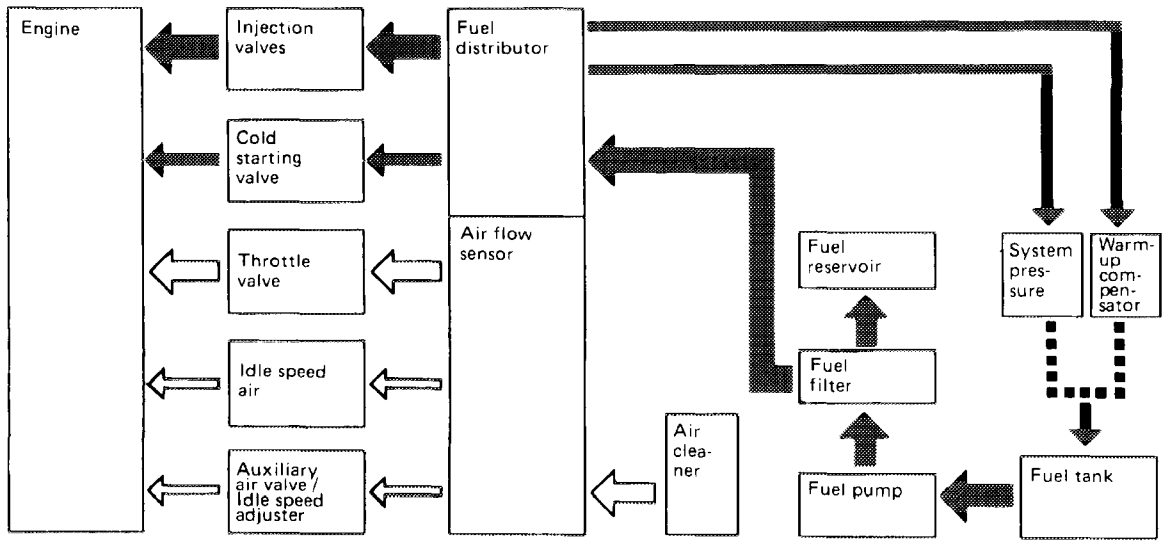
Function diagram



1074-11503/1

-  Air
-  Fuel
-  Return flow

Components of CIS injection system
(prior to September 1981)

Engine 116.960/961, 117.960/961

Characteristics:

- Fuel distributor made of light alloy with integrated pressure compensating valve.
- Fuel pump with external check valve.
- Fuel reservoir located in parallel – 1 connection on pressure side.

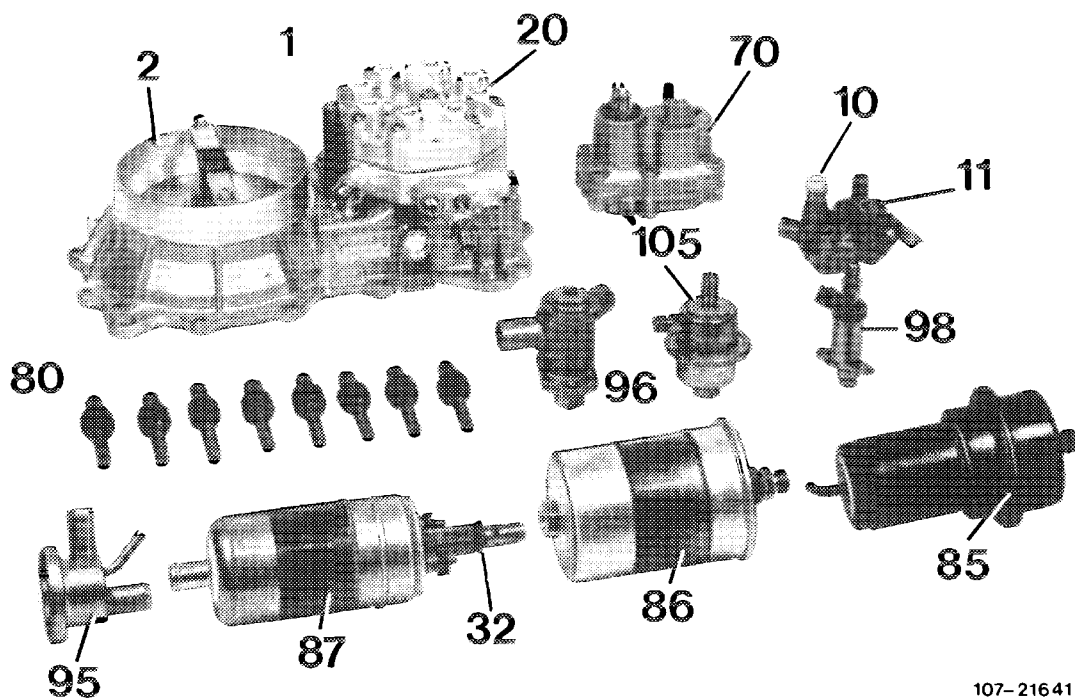

107-21641

1 Mixture control unit
2 Air flow sensor
10 Idle speed air screw
11 Idle speed air distributor
20 Fuel distributor

32 Check valve
70 Warm-up compensator
80 Injection valves
85 Fuel reservoir
86 Fuel filter

87 Fuel pump
95 Intake damper
96 Auxiliary air valve
98 Cold start valve
105 Pressure damper

Components of CIS injection system
(starting September 1981)

Engine 116.962/963, 117.962/963

Characteristics:

- Electronically controlled idle speed adjuster.
- Idle speed air screw, auxiliary air valve and pressure damper are no longer included.

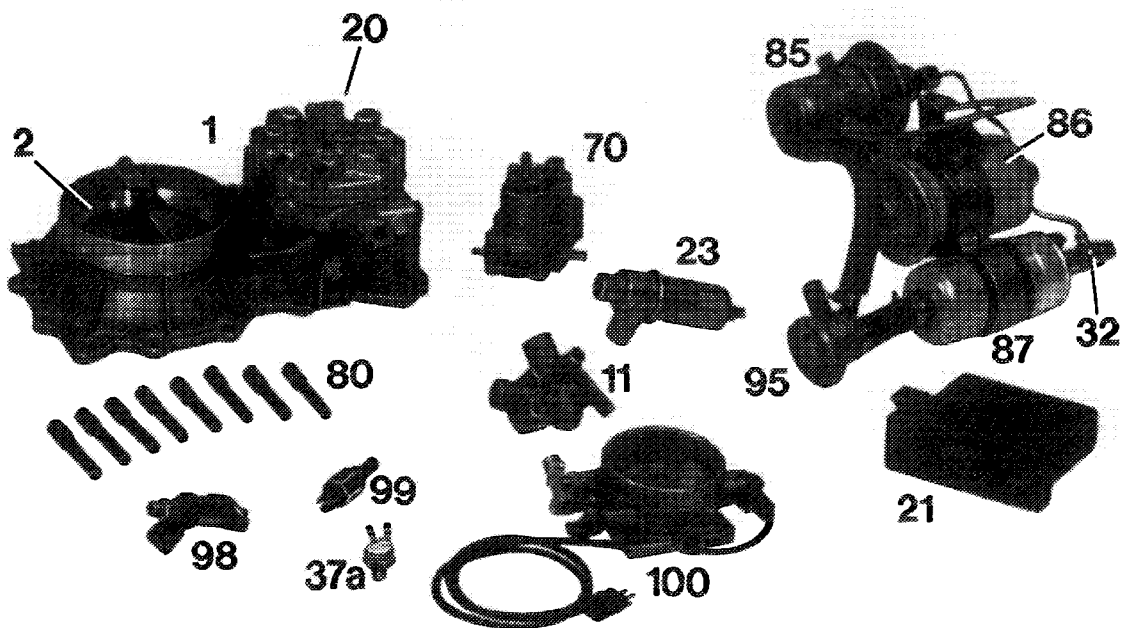

107-26338

- 1 Mixture control unit
- 2 Air flow sensor
- 11 Idle speed air distributor
- 20 Fuel distributor
- 21 Control unit
- 23 Idle speed adjuster
- 32 Check valve

- 37a Thermo valve 50 °C for acceleration enrichment
- 70 Warm-up compensator
- 80 Injection valves
- 85 Fuel reservoir
- 86 Fuel filter
- 87 Fuel pump

- 95 Intake damper
- 98 Cold start valve
- 99 Thermo time switch
- 100 Throttle valve housing with throttle valve switch

B. Operation

Diagrammatic view of injection systems

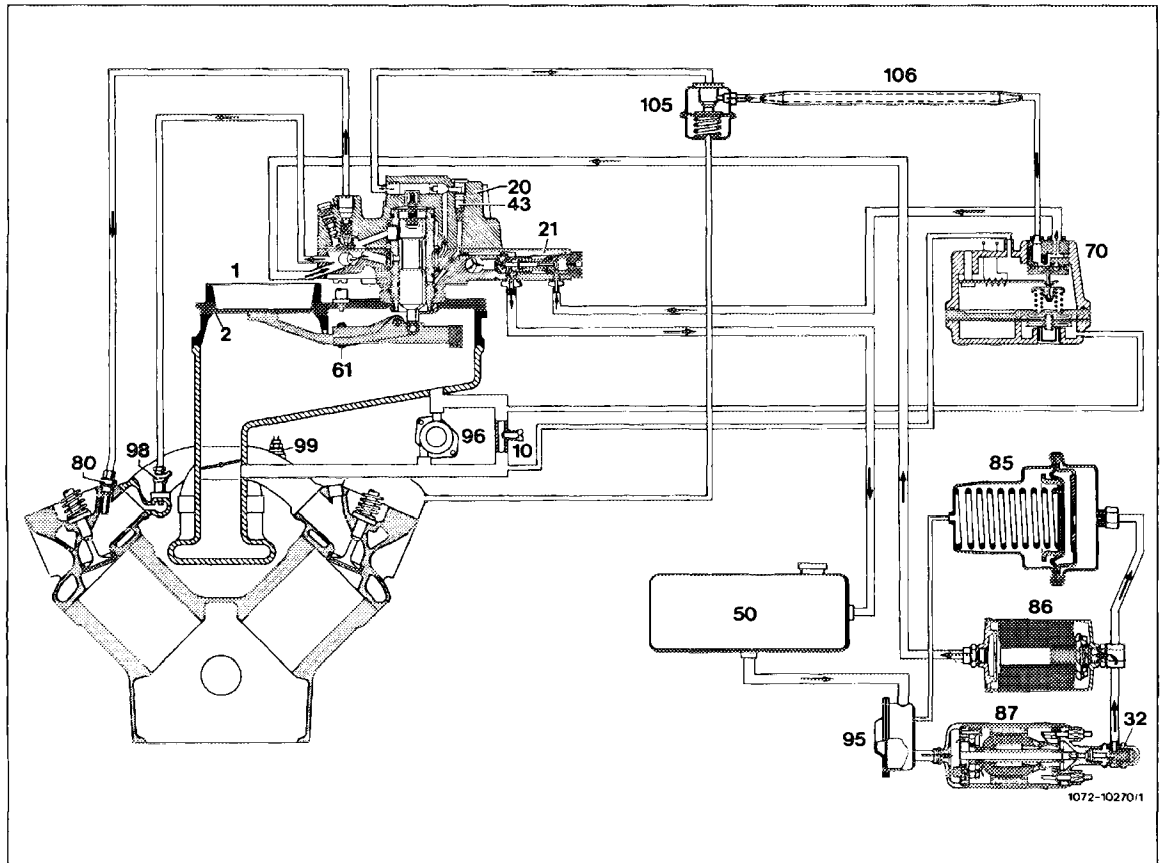

Prior to September 1981

- 1 Mixture control unit
- 2 Air flow sensor
- 10 Idle speed air screw
- 20 Fuel distributor
- 21 System pressure regulator
- 32 Check valve
- 43 Pressure relief valve
- 50 Fuel tank
- 61 Idle mixture adjusting screw

- 70 Warm-up compensator
- 80 Injection valve
- 85 Fuel reservoir
- 86 Fuel filter
- 87 Fuel pump
- 95 Diaphragm damper

- 96 Auxiliary air valve
- 98 Cold start valve
- 99 Thermo time switch
- 105 Pressure damper
- 106 Control pressure line with tecalan element

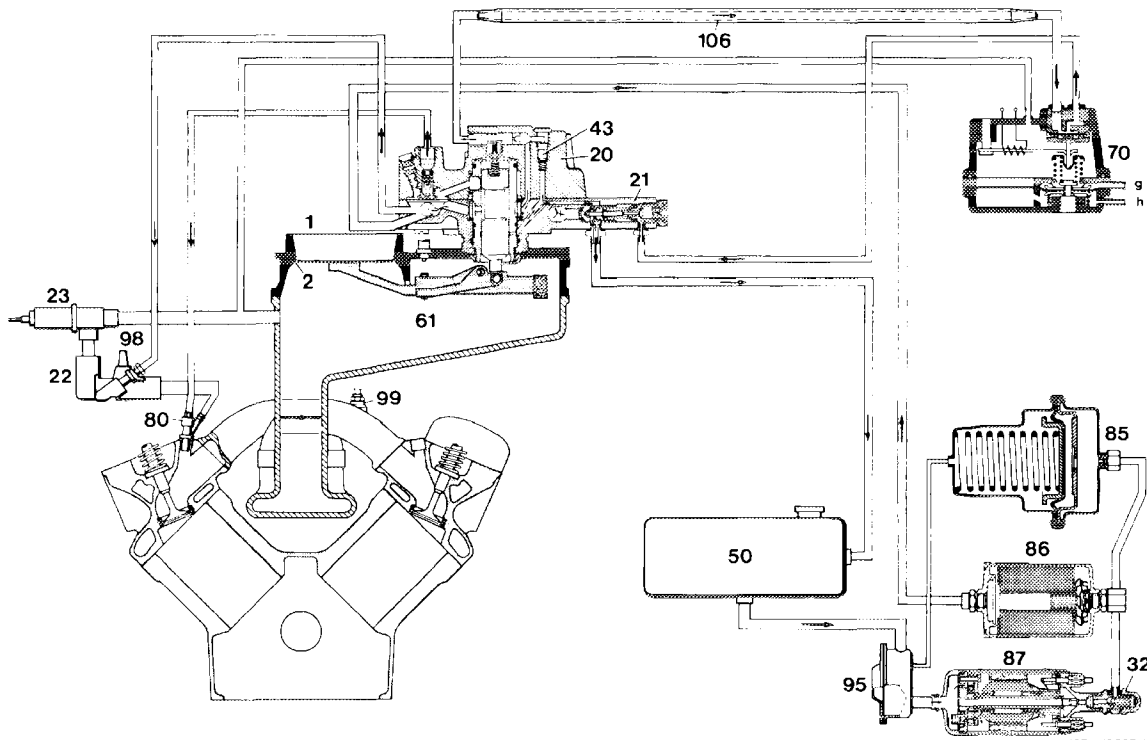

1072-10337-1

Starting September 1981

- | | | |
|---------------------------------------|------------------------|---|
| 1 Mixture control unit | 70 Warm-up compensator | 106 Control pressure line
with tecalan element |
| 2 Air flow sensor | 80 Injection valve | g Upper chamber |
| 20 Fuel distributor | 85 Fuel reservoir | h Lower chamber |
| 21 System pressure regulator | 86 Fuel filter | |
| 22 Idle speed air distributor | 87 Fuel pump | |
| 23 Idle speed adjuster | 95 Diaphragm damper | |
| 32 Check valve | 98 Cold start valve | |
| 43 Pressure relief valve | 99 Thermo time switch | |
| 50 Fuel tank | | |
| 51 Idle-speed-mixture adjusting screw | | |

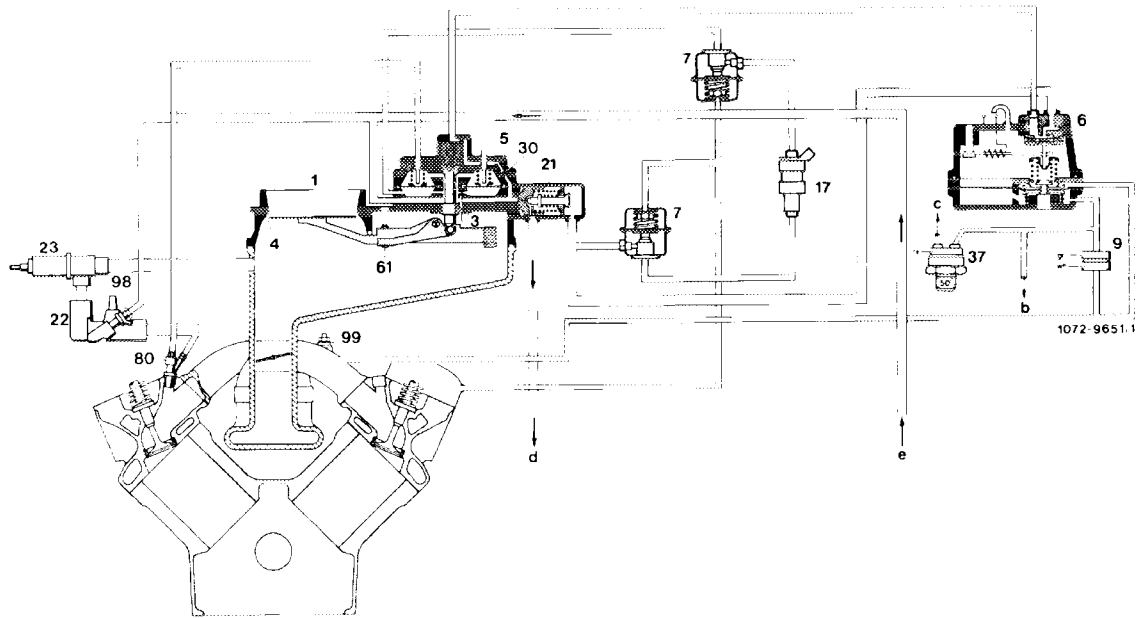

(J) (USA)

- | | |
|-------------------------------|---------------------------------------|
| 1 Mixture control unit | 30 Pressure relief valve |
| 3 Orifice | 37 Thermo valve 50 °C |
| 4 Air flow sensor | 61 Idle speed-mixture adjusting screw |
| 5 Fuel distributor | 80 Injection valve |
| 6 Warm-up compensator | 88 Cold start valve |
| 7 Pressure damper | 99 Thermo time switch |
| 9 Orifice | |
| 17 Timing valve | b To ignition distributor |
| 21 System pressure regulator | c To intake manifold |
| 22 Idle speed air distributor | d Fuel return flow |
| 23 Idle speed adjuster | e Fuel feed |

Color code
 gr = green
 re = red
 wh = white

Note: For checking lambda control refer to combustion III (14–100).

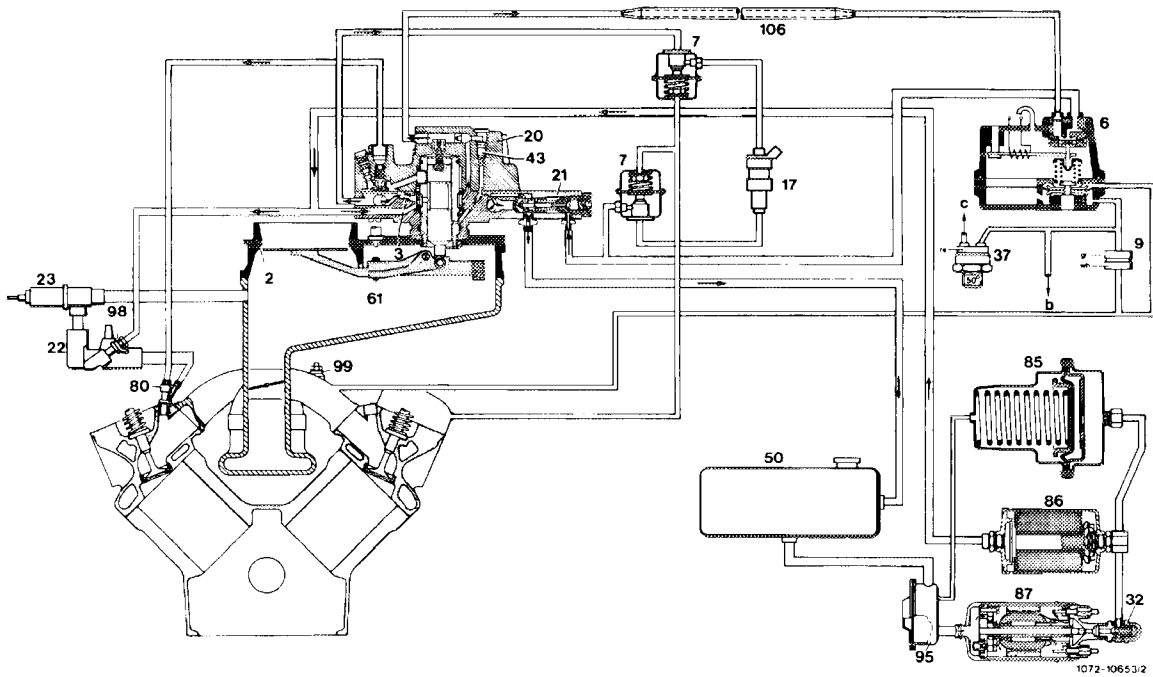

1072-10653/2

J USA

- | | |
|--|---|
| <ul style="list-style-type: none"> 2 Air flow sensor 3 Orifice 4 Air flow sensor 6 Warm-up compensator 7 Pressure damper 9 Orifice 17 Timing valve 20 Fuel distributor 21 System pressure regulator 22 Idle speed air distributor 23 Idle speed adjuster 32 Check valve 37 Thermo valve 50 °C 43 Pressure relief valve 50 Fuel tank | <ul style="list-style-type: none"> 61 Idle speed-mixture adjusting screw 80 Injection valve 85 Fuel reservoir 86 Fuel filter 87 Fuel pump 95 Diaphragm damper 98 Cold start valve 99 Thermo time switch 106 Control pressure line with tecalan element |
|--|---|

Color code
 gr = green
 re = red
 wh = white

- b To ignition distributor
- c To intake manifold

Note: For checking lambda control refer to combustion III (14–100).

The fuel is drawn by electric fuel pump through a damper out of fuel tank and is delivered to the fuel distributor on mixture control unit via fuel filter and fuel reservoir.

A pressure regulator in fuel distributor keeps the system pressure constant. Excess fuel flows pressureless back to fuel tank.

The fuel pump is energized only when the starter is actuated and as long as the engine is running.

The mixture control unit comprises the air flow sensor and the fuel distributor. The air quantity aspirated by the engine is measured in air flow sensor by way of an air flow sensor plate.

For this purpose, the air flow sensor plate is moving in an air funnel and will take a given position in accordance with intake air quantity (floating body principle). This movement of the air flow sensor plate is transmitted to control piston in fuel distributor by means of a lever.

The control pressure acting on control piston opposes this movement. The control piston is moving in a slit carrier, which is centrally located in fuel distributor. The slit carrier is provided with vertical slits, the control or metering slits, in accordance with number of cylinders in engine.

The changing cross section of control slits adapts the fuel quantity to the intake air quantity. Each control slit is provided with a differential pressure valve which keeps the pressure drop on control slit constant independent of cross section.

The fuel flows from the differential pressure valves via injection lines to the injection valves, which are injecting the fuel continuously in front of the cylinder intake valves. When the intake valves are opening, the fuel is drawn with the air into the engine cylinders.

Auxiliary equipment

A warm-up compensator regulates the control pressure, which acts on the control piston and serves for enriching the mixture during warm-up stage and at full load.

An auxiliary air valve which is controlled by an expansion element in dependence of the coolant temperature provides a larger mixture quantity during warm-up period. Starting September 1981, this function is performed by an electronically controlled idle speed adjuster.

A cold start valve serves as a cold start aid.

C. Layout and function

Mixture control unit

The mixture control unit is a component comprising the air flow sensor and the fuel distributor.

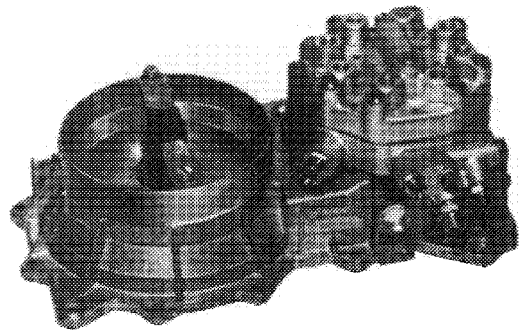

107-21636

Air flow sensor

The air flow sensor (1) comprises an air funnel and an air flow sensor plate (4) fastened to a lever (2). The lever swivels around a pivot (3). The dead weight of the air flow sensor plate is compensated by a counterweight (5).

The entire intake air quantity of engine is measured in air flow sensor which is installed in front of throttle valve.

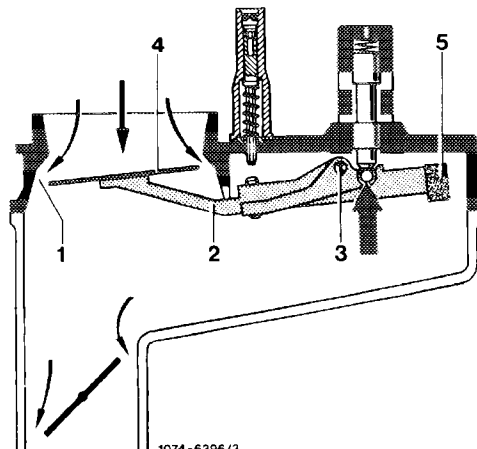

1074-6396/3

Measuring of the air quantity is based on floating-body principle, which says, that a floating body is moving in a uniform cone in linear relation with air flow.

At stroke (a) the floating body shown in illustration clears the annular surface (a 1). The result is: The larger the quantity passing through the opening, the larger the floating body stroke.

In air flow sensor of mixture control unit, the air flow sensor plate is the floating body, the air funnel is the cone.

The air quantity aspirated by the engine changes the position of the air flow sensor plate. This air flow sensor plate stroke is transmitted by means of a lever with a definite ratio to the control piston which regulates the fuel flow rate through control slits.

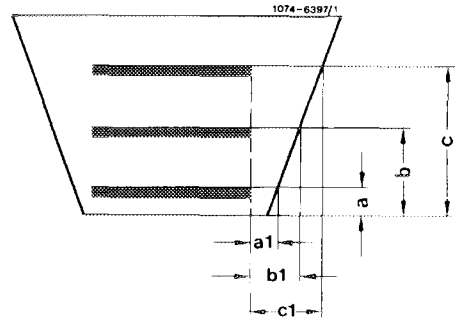

The following forces will become effective at air flow sensor: The intake air acts as an air force (F 1) on air flow sensor plate. The opposing force is the hydraulic force (F 2) of control pressure, which acts on control piston by way of an orifice.

The dead weight of the air flow sensor plate and the lever, force (F 3), is compensated by the counter-weight (F 4).

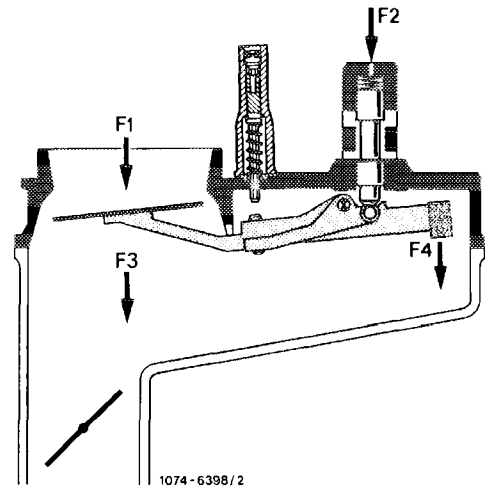

The position of the air flow sensor plate keeps changing until the air force (F 1) and the hydraulic force (F 2) are in balance.

As a result, the air flow sensor plate deflection and thereby the position of the control piston with reference to air flow rate can be influenced by the control pressure.

Each engine has a given characteristic field, that is, the mixture must be enriched in given load and rpm ranges, in others, the mixture must be made leaner.

This precise adaptation to the engine characteristics is determined by the shape of the air funnel. For this reason, the air funnel deviates from a pure cone shape.

Note: No subsequent changes should therefore be made on air funnel and on air flow sensor plate.

Example: If the correction stage in air funnel is wider than the cone, the air flow sensor plate stroke in corrected air funnel is smaller with the air flow rate remaining the same. The fuel air mixture is getting leaner.

Funnel cone

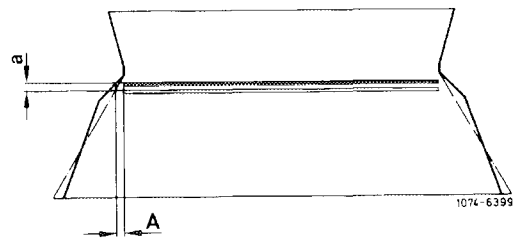

If the correction stage in air funnel is tighter than the cone, the air flow sensor plate stroke is higher with the air flow rate remaining the same. The fuel air mixture is getting richer.

Funnel cone

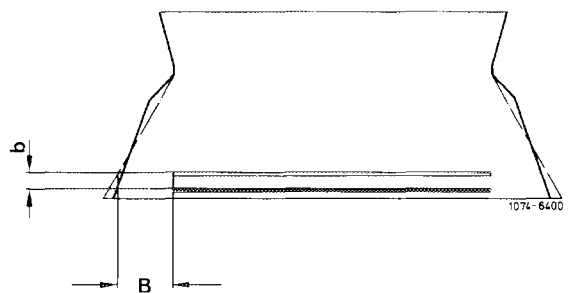

On stopped engine the air flow sensor plate is seated at the closest (narrowest) point of air funnel. The rest position is provided by a resilient stop. The air funnel is getting wider also in the opposite direction, so that in the event of an engine kickback, the pressure can be reduced. The air flow sensor plate will then overcome the resilient stop.

Fuel distributor

The fuel distributor distributes the fuel quantity to the individual cylinders in accordance with position of air flow sensor plate in air flow sensor.

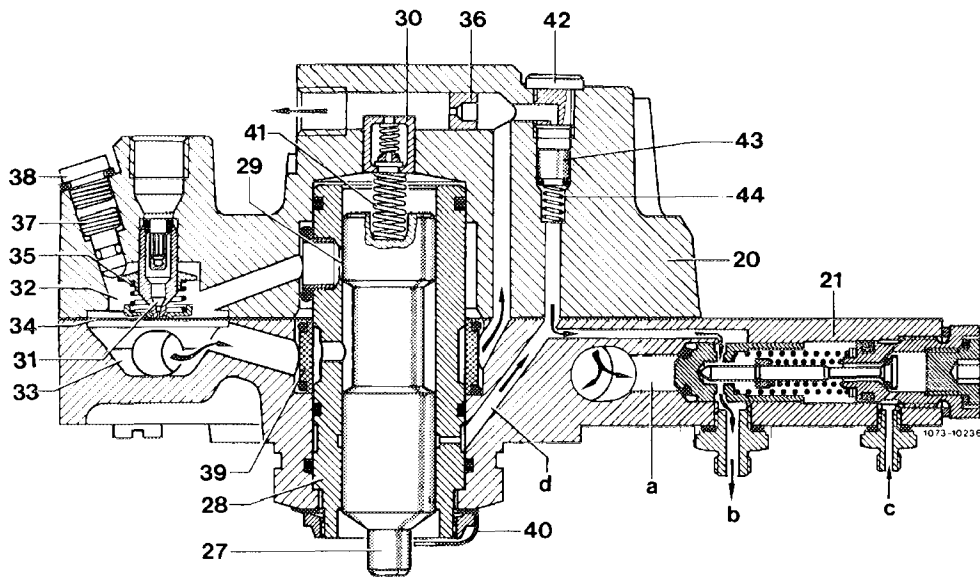

20 Fuel distributor

21 System pressure regulator

27 Timing piston

28 Slit carrier

29 Control slit

30 Damping restriction

31 Differential pressure valve

32 Upper chamber

33 Lower chamber

34 Diaphragm

35 Compression spring

36 Orifice

37 Differential pressure-adjusting screw

38 Closing plug

39 Filter

40 Sheet metal lock

41 Compression spring

42 Closing plug

43 Piston

44 Compression spring

a System pressure

b Return flow to fuel tank

c Return from warm-up compensator

d Return flow from control piston

The fuel distributor is made of light alloy and comprises two housing halves. The fabric diaphragm (34) between the upper and lower half separates the interior of the fuel distributor into the lower and the upper chambers (32 and 33).

The fuel is delivered by the electric fuel pump, first into the lower chambers (33), which are connected with each other.

The connection from the lower chambers (33) to the upper chambers (32) and thereby also to the injection valves is established by the slit carrier (28) and the control piston (27).

- 27 Control piston
- 28 Slit carrier
- 29 Control slit
- 30 Control edge
- a Rest position
- d Fuel inlet (lower chamber)
- e To upper chamber

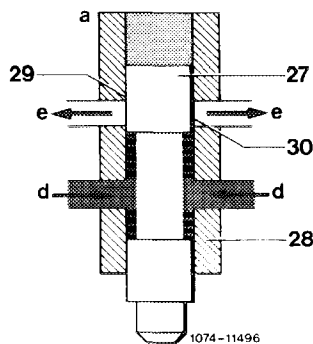
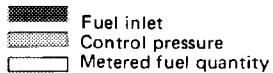

- b Partial load
- c Full load

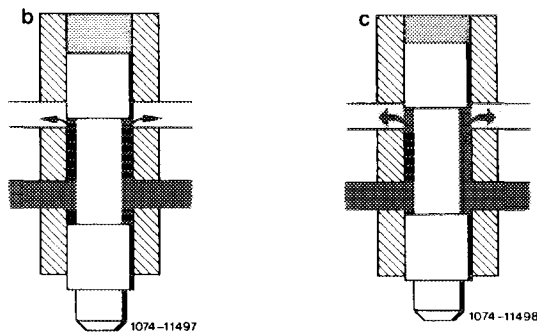
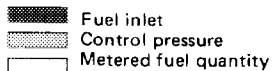

The slit carrier (28) is a hollow cylinder into which the control slits (29), slits 0.1–0.2 mm wide and 5 mm high, are machined. Each engine cylinder has one control slit.

The control piston (27) in slit carrier (28) determines with its control edge (30) the opening cross section of the control slits (29) and thereby the flow rate to the upper chamber and the injection valves.

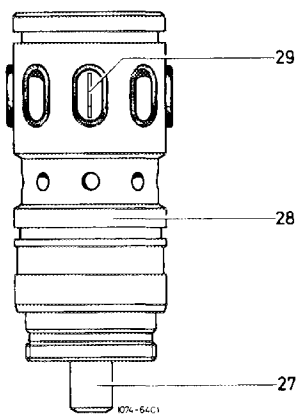

- 27 Control piston
- 28 Slit carrier
- 29 Control slit
- 30 Control edge
- d Fuel inflow (lower chamber)
- e To upper chamber

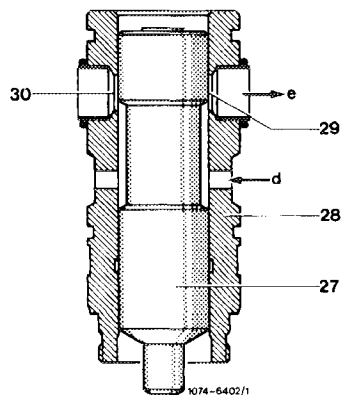

Each control slit with a differential pressure valve which keeps the pressure drop (differential pressure) at control slits constant independent of control slit opening. As a result, the metered fuel quantity depends exclusively from the exposed cross section.

Fluctuations of system pressure and deviations of injection valve opening pressure have no influence. The characteristic line control piston stroke — fuel quantity is linear.

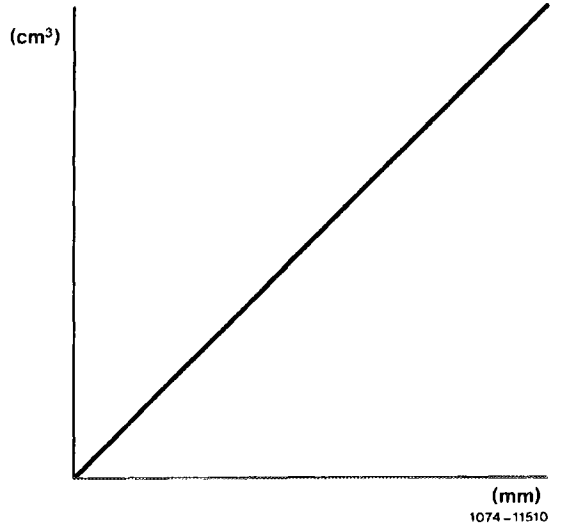

(mm)
1074-11510

The differential pressure valves (31) are divided into lower and upper chambers by a diaphragm (34). The lower chambers (33) are connected by means of an annular channel. The pressure in lower chambers corresponds to system pressure. The pressure in the upper chambers (32) is lower by the differential pressure of 0.1 bar. This difference is provided by the compression spring (35) installed in upper chamber, as a result of which an equilibrium of forces is attained on diaphragm between upper and lower chamber.

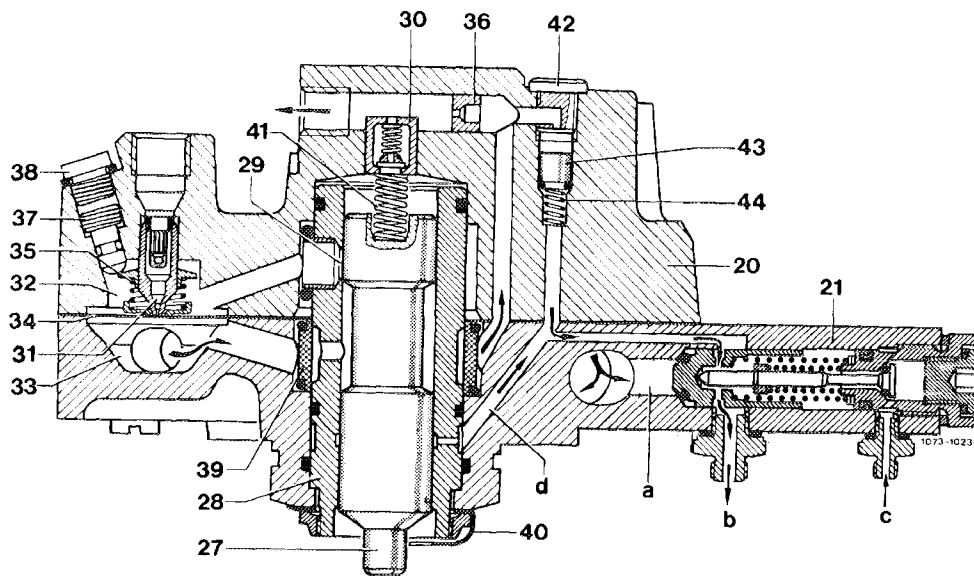

20 Fuel distributor
21 System pressure regulator
27 Control piston
28 Slit carrier
29 Control slit
30 Damping restriction
31 Differential pressure valve
32 Upper chamber
33 Lower chamber
34 Diaphragm

35 Compression spring
36 Orifice
37 Differential pressure-adjusting screw
38 Closing plug
39 Filter
40 Sheet metal lock
41 Compression spring
42 Closing plug
43 Piston
44 Compression spring

a System pressure
b Return flow to fuel tank
c Return flow from warm-up compensator
d Return flow from control piston

Function of differential pressure valves: If the flow rate on control slit (29) is increased, the pressure in upper chamber (32) is temporarily increased, so that the differential pressure is getting less than 0.1 bar. Since the spring force supports the pressure on diaphragm top, the diaphragm arches more in downward direction and therefore exposes a larger outflow cross section toward injection valve. The fuel pressure against diaphragm top is thereby again reduced. There is once again equilibrium between diaphragm upper and lower side, the diaphragm remains in wide-open position.

Vice versa, the pressure against diaphragm top drops when the control slit is closed (the differential pressure is increasing). The outflow cross section will be reduced until equilibrium is once again established.

This procedure is repeated during each new control piston position, that is, during each change of air flow sensor plate position.

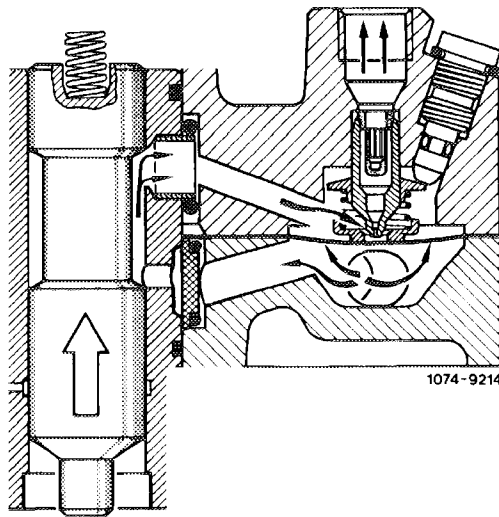

The fuel distributor top has 8 closing plugs (38) with adjusting screws (37) for differential pressure valves (31) underneath. The differential pressure valves are set by manufacturer, readjustment is not permitted.

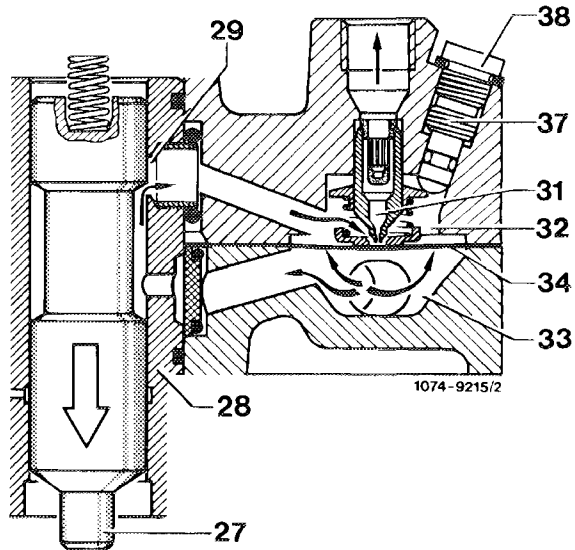

- 27 Control piston
- 28 Slit carrier
- 29 Control slit
- 31 Differential pressure valve
- 32 Upper chamber
- 33 Lower chamber
- 34 Diaphragm
- 37 Closing plug
- 38 Adjusting screw

A pressure compensating valve (arrow) is integrated with fuel distributor top.

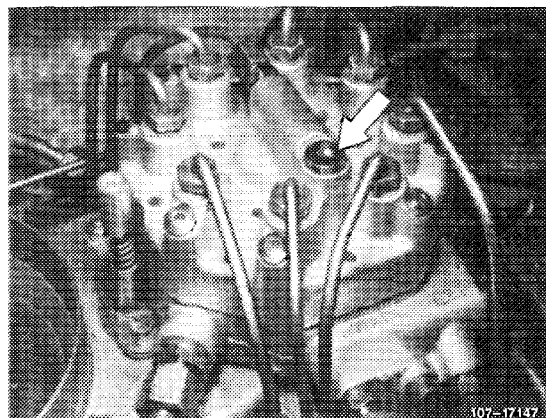

The pressure compensating valve remains closed as long as the fuel system is under pressure.

In the event of a pressure drop "following a long stationary period and cooling down of fuel" below 0.3–0.05 bar gauge pressure the pressure compensating valve will open.

Piston (2) is raised and pressure compensation between system pressure and return flow pressure proceeds by way of piston gap.

- a System pressure
- b Return flow

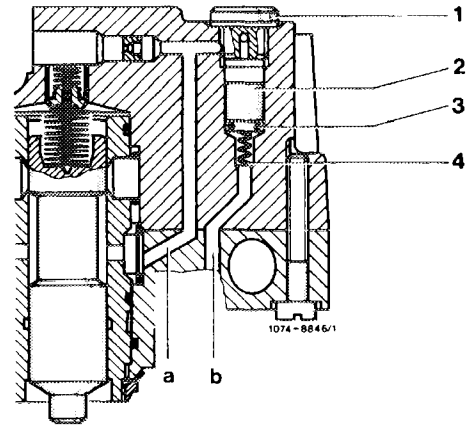

This will prevent that the control piston in fuel distributor is raised in direction of full load when the engine is stopped and that a high enrichment of mixture shows up during a cold start.

The fuel system is subdivided into the following pressure circuits:

System pressure circuit

The system pressure circuit has a constant over-pressure. The pressure extends from fuel pump via fuel filter, fuel reservoir, fuel distributor (differential pressure valve-diaphragm underside) to cold start valve.

The differential pressure valve-diaphragm top in fuel distributor is subject to system pressure reduced by 0.1 bar.

The pressure in fuel lines from fuel distributor to injection valves corresponds to opening pressure of injection valves.

The excess fuel flows pressureless from system pressure regulator in fuel distributor through return flow line back to fuel tank.

Control pressure circuit

In fuel distributor the control pressure circuit is branched-off from system pressure circuit by means of an orifice (36). The orifice is in top of fuel distributor.

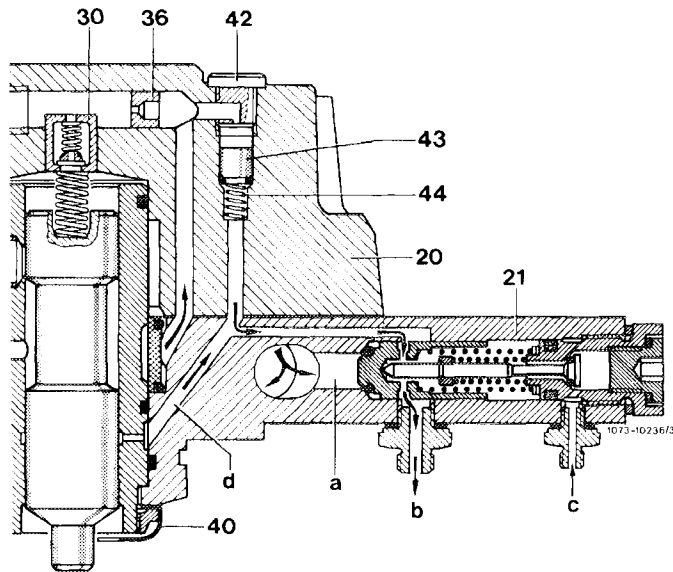

The control pressure circuit has a variable pressure of 0.5–3.8 bar gauge pressure which is controlled by warm-up compensator depending on temperature and load.

The control pressure acts on top of control piston as a counterforce to the air pressure occurring at air flow sensor plate.

High control pressure = less fuel
(lean mixture)

Low control pressure = more fuel
(richer mixture)

A capsule valve with a damping restriction (30) is located between the space above control piston and control pressure line.

The capsule valve serves for quick emptying of area above control piston during transition into warm-up stage. The restriction dampens the movements of the air flow sensor plate in the event of a pulsating air flow.

Simultaneously, the restriction determines the degree of excessive oscillation of air flow sensor plate and thereby the momentary transition enrichment during acceleration. As a result, the transition characteristics during acceleration are improved.

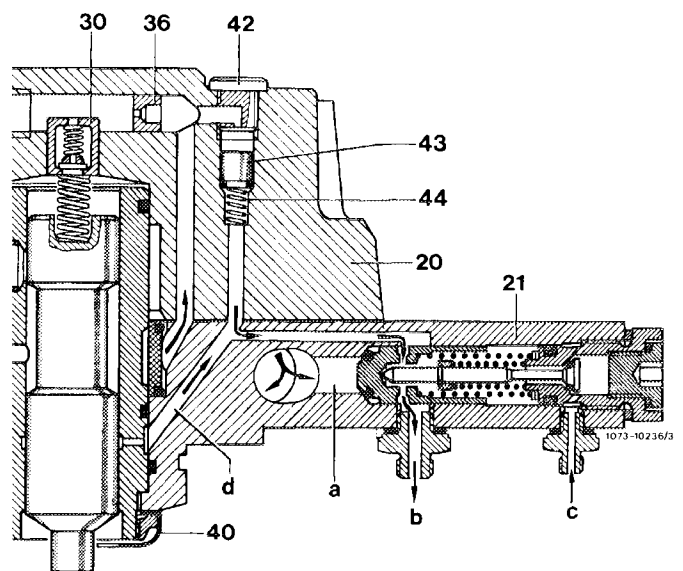

During acceleration, the quick emptying of the space above the control piston results in pressure peaks in control pressure line. To make sure that these pressure peaks are not damaging the diaphragm in warm-up compensator, a pressure damper (105) or a tecalan element is installed in control pressure line (106).

1st version

Control pressure line with pressure damper (105) and tecalan element (106). The tecalan element is closed at the front and at the rear (float).

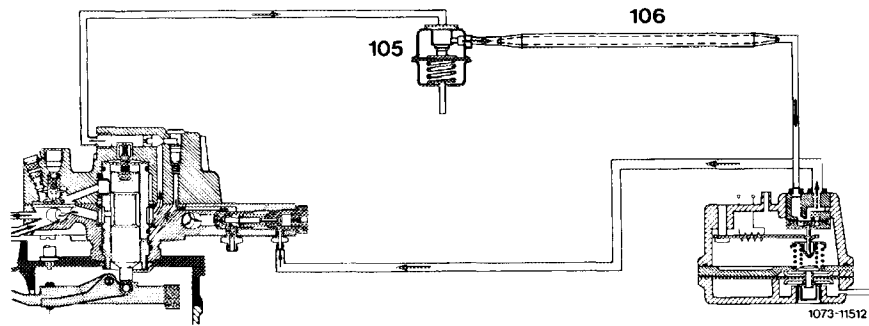

2nd version

The tecalan element in control pressure (106) has been extended. This made installation of pressure damper unnecessary.

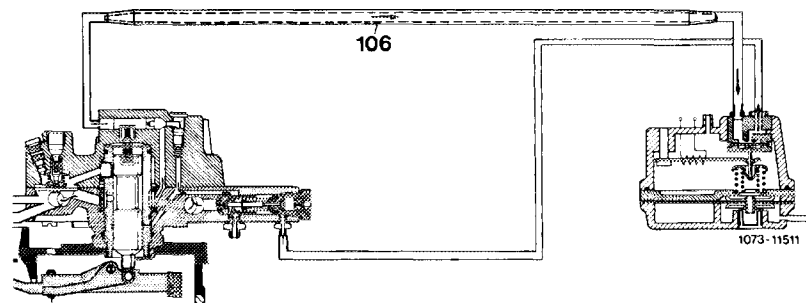

Damper

To avoid noises, a diaphragm damper is installed between fuel tank and fuel pump.

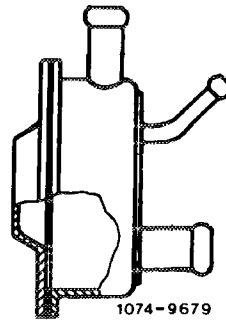

Fuel pump:

Characteristics:

- Roller-cell pump.
- Driven by a permanently excited electric motor.
- Fuel flowing through pump ("wet pump").
- No risk of explosion; due to a shortage of oxygen, no ignitable mixture can be formed in the relatively small spaces.

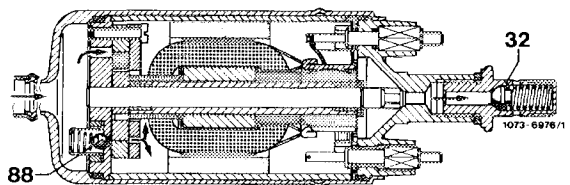

32 Check valve
88 Pressure relief valve

Operation

The rotor disk (1) has 5 pocket-shaped recesses with a roller (2) located in each recess. Centrifugal forces are pushing the rollers outwards against rotor ring in fuel pump housing (3), where they are serving as sealing rings. The eccentric location of rotor ring in fuel pump housing (3) in relation to rotor disk (1) changes the volume between the rollers, so that a delivery effect is obtained.

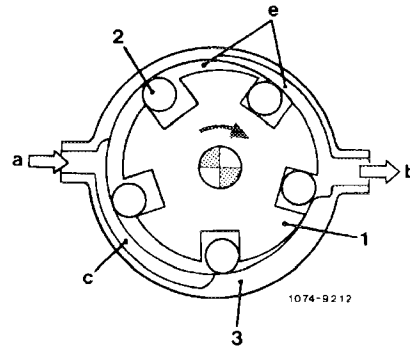

- 1 Rotor disk
- 2 Roller
- 3 Pump housing with rotor ring
- a Suction side
- b Pressure side
- c Fuel, pressureless
- d Fuel delivery
- e Fuel under pressure

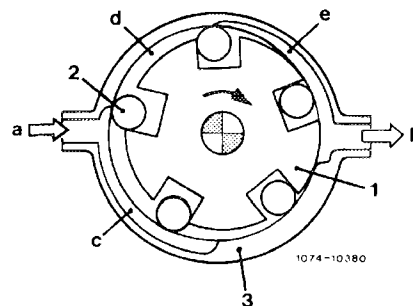

The delivery capacity of the fuel pump is designed in such a manner that the necessary pressure in fuel system is provided in all operating conditions, so that the engine is always provided with cool fuel.

The pressure relief valve (88) opens at a pressure of approx. 8 bar and connects the suction side with the pressure side inside fuel pump. This will prevent an additional pressure increase, e.g. at narrow spots in pressure or return flow system.

On stopped engine, the check valve (32) prevents that the fuel pressure is reduced by way of fuel pump. As a result, fuel vapor lock will be widely eliminated.

The fuel pump is provided with electric current by means of a relay. The fuel pump is therefore running only:

- a) When the starter is operated.
- b) When the engine is running.

This will prevent the delivery of fuel with the ignition switched on and the engine stopped (e.g. following an accident).

Fuel filter

The fuel filter is a fine filter with paper element. The fuel flow direction is indicated by arrows. A damper is installed to eliminate noise.

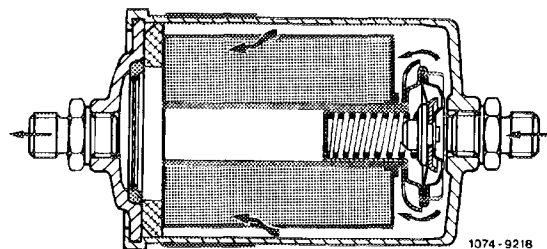

Fuel reservoir

The interior of the fuel reservoir is subdivided into a spring and storage chamber.

As soon as the fuel pump is running, the reservoir is filled and the diaphragm spring is preloaded. In this position, which corresponds to the max. storage volume, the diaphragm remains under tension as long as the engine is running.

With the engine stopped, the pressure in fuel system remains intact until the storage volume is exhausted. The respective time depends on the inner sealing of the system. For safety reasons, the spring chamber of the fuel reservoir is connected to the damper of the fuel pump by way of the leak line. As a result, no fuel can flow out in the event of a defective diaphragm.

During operation, the fuel reservoir contributes to the damping of fuel pump noise.

The fuel reservoir is located in parallel to fuel filter. It is filled through orifice (arrow) only slowly with fuel. From the fuel filter, the fuel flows directly into the feed line toward engine. These measures serve to establish the fuel pressure at the injection valves faster, which in turn will favor starting characteristics and smooth running after starting.

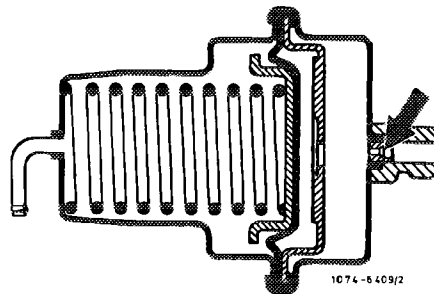

After the engine has been stopped, the fuel system is kept under pressure for a given period under influence of fuel reservoir.

This will widely prevent fuel vapor lock in fuel system, which in turn will improve hot starting characteristics.

System pressure regulator

The system pressure regulator is a piston pressure regulator and integrated in fuel distributor. The system pressure regulator has the following functions:

- a) Controlling the system pressure.
- b) After stopping engine, making sure that the system pressure drops quickly under influence of opening pressure of injection valves, so that injection valves are reliably closing.
- c) Sealing the system and control pressure circuit in relation to return flow, so that the pressure in fuel system is maintained for a longer period and that a good hot start is obtained.

The fuel is delivered by the fuel delivery pump initially into the lower chambers of the fuel distributor, which are connected by an annular channel.

Since the fuel pump delivers more fuel than the engine consumes, the pressure in the lower chambers increases.

This will displace the regulator piston (22) against force of spring (24) to clear the fuel return flow (b) to the extent that the fuel pressure in system pressure circuit attains the preset value.

During this procedure, the regulator piston (22) will also open the push-up valve (22a) and thereby establish a connection from warm-up compensator-return flow (c) to fuel return flow (b).

System pressure regulator in closed position

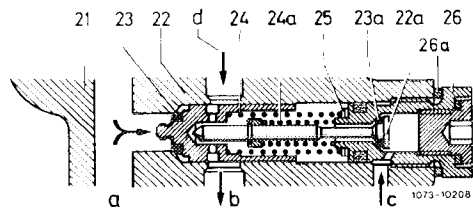

With the fuel delivery pump stopped, the regulator piston is returned to its sealing surface by the force of spring (24). The push-up valve (22a) can now also be pushed back to its closing position by the force of spring (24a). With the push-up valve closed, the fuel return flow from warm-up compensator is interrupted.

System pressure regulator in opened position

- | | |
|------------------------------|---|
| 21 System pressure regulator | a System pressure |
| 22 Regulator piston | b Return flow to fuel tank |
| 22a Return flow valve | c Return flow from warm-up compensator |
| 23 Contour ring | d Return flow from control piston leak quantity |
| 23a O-ring, vulcanized-on | |
| 24 Compression spring | |
| 24a Compression spring | |
| 25 Washer | |
| 26 Closing plug | |
| 26a Copper sealing ring | |

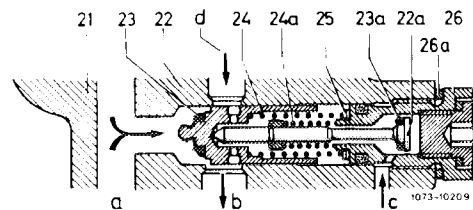

Injection valves

Each cylinder is associated with an injection valve.
The injection valves are mounted in intake manifold.

The injection valves are atomizing the fuel even in minimum quantities to an extremely fine degree by means of an installed blow valve.

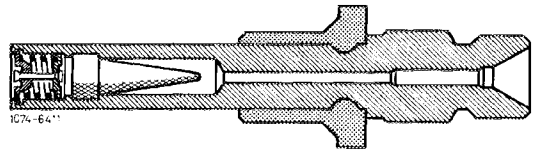

Auxiliary air valve

During the warm-up period, the engine requires an increased quantity of mixture to overcome the increased friction losses and to obtain perfectly smooth running characteristics.

The auxiliary air valve is controlled by an expansion element and supplies the engine with additional air in dependence of the coolant temperature.

Since this additional air is measured by means of the air flow sensor plate, the control piston distributes the pertinently increased quantity of fuel.

The auxiliary air valve is:

Open below -20°C ,
closed above $+65^{\circ}\text{C}$.

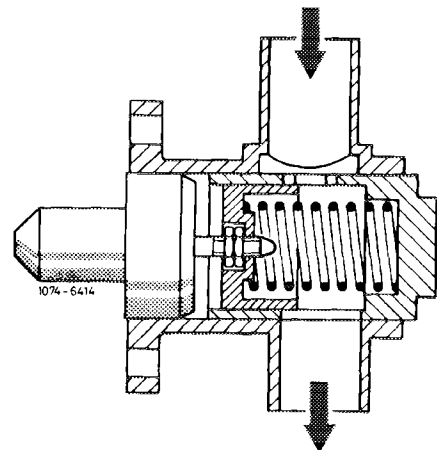

Starting September 1981, the auxiliary air valve has been replaced by an electronically controlled idle speed adjuster (refer to electronic idle speed control).

Cold start valve

The electromagnetic cold start valve is activated by system pressure. It is controlled via terminal 50 and by a thermo time switch. The thermo time switch is closed at temperatures below +15 °C coolant temperature. The closing time of the thermo time switch and thereby the opening time of the cold start valve increases with decreasing temperature and amounts to 12 seconds at -20 °C.

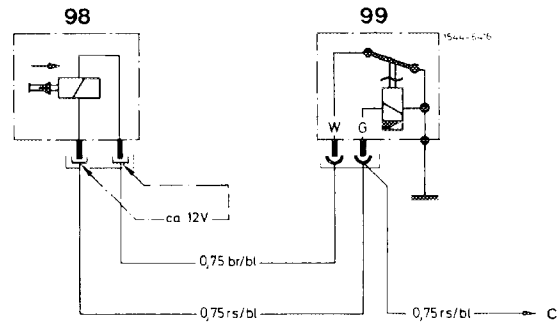
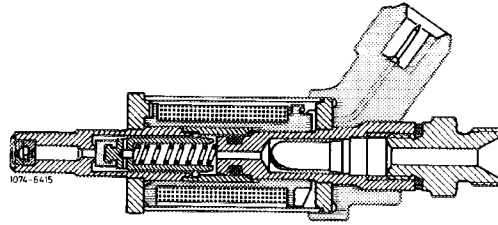

98 Cold start valve
99 Thermo time switch
c To terminal 50

Warm-up compensator

The warm-up compensator regulates the control pressure, which acts on control piston and serves for enriching the mixture during warm-up stage and at full load.

Two fuel lines, the control pressure line and the return flow line, are connected to warm-up compensator.

The control pressure acts on top of diaphragm valve (71), which throttles the outflow cross section of the return flow line.

Two valve springs (72 and 73), which are tuned to the normal control pressure, are effective at underside.

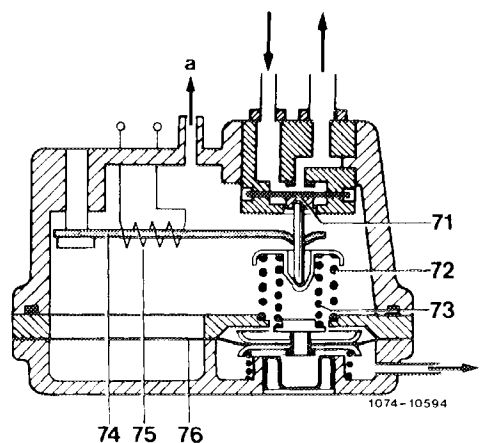

71 Diaphragm valve
72 Outer valve spring
73 Inner valve spring
74 Bimetall strip
75 Heater coil
76 Vacuum diaphragm
a To intake manifold (vacuum)
i To leak line (atmosphere)

A bimetallic strip (74), which is provided with a heater coil (75), is installed for enrichment during warm-up stage. The cold bimetallic strip acts in opposition to valve springs (72 and 73), so that the diaphragm valve (71) opens and the control pressure is reduced. Heating up will gradually eliminate the effect of the bimetallic spring until the control pressure has attained its normal value.

Full load enrichment

Prior to September 1981

For full load enrichment the warm-up regulator is divided into two chambers by means of a vacuum diaphragm (76). The intake manifold vacuum "a" is effective in upper chamber. The lower chamber is connected to atmosphere via connection "i".

To avoid the entry of dirt or water, the venting system is connected to contour hose (arrow).

At idle and in partial load range the upper chamber is subject to a vacuum and the vacuum diaphragm (76) is resting against upper stop. In this position, the spring force provides the normal value of the control pressure.

At full load, the vacuum in upper chamber is reduced and the vacuum diaphragm (76) is moving downwards. The force of the inner valve spring (73) is getting less and the control pressure is thereby reduced to the full load value.

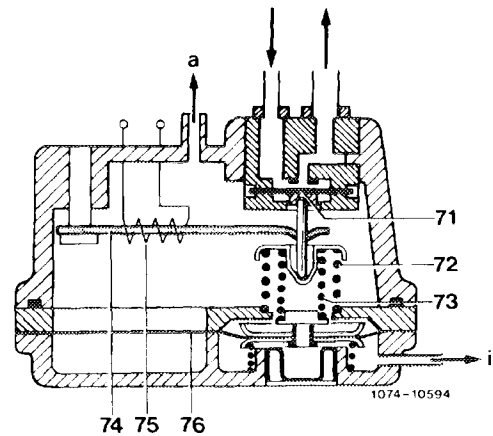
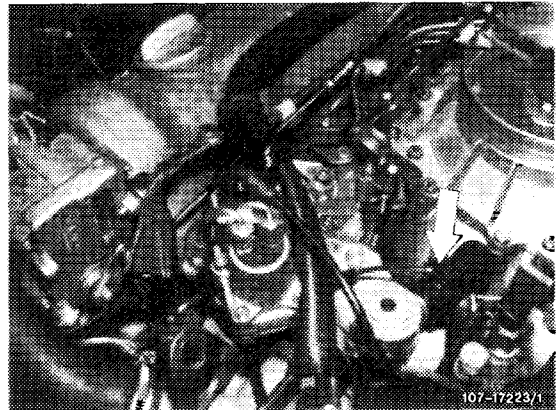

Starting September 1981

The full load enrichment is mechanically/pneumatically controlled. In full load position of throttle valve, the switchover valve (13) is switched by means of a guide lever (11a). Connections (e and c) are now connected and the vacuum from vacuum reservoir (14) is acting on vacuum chamber (connection h) of warm-up compensator.

The vacuum reservoir (14) is mounted in lefthand front wheel house.

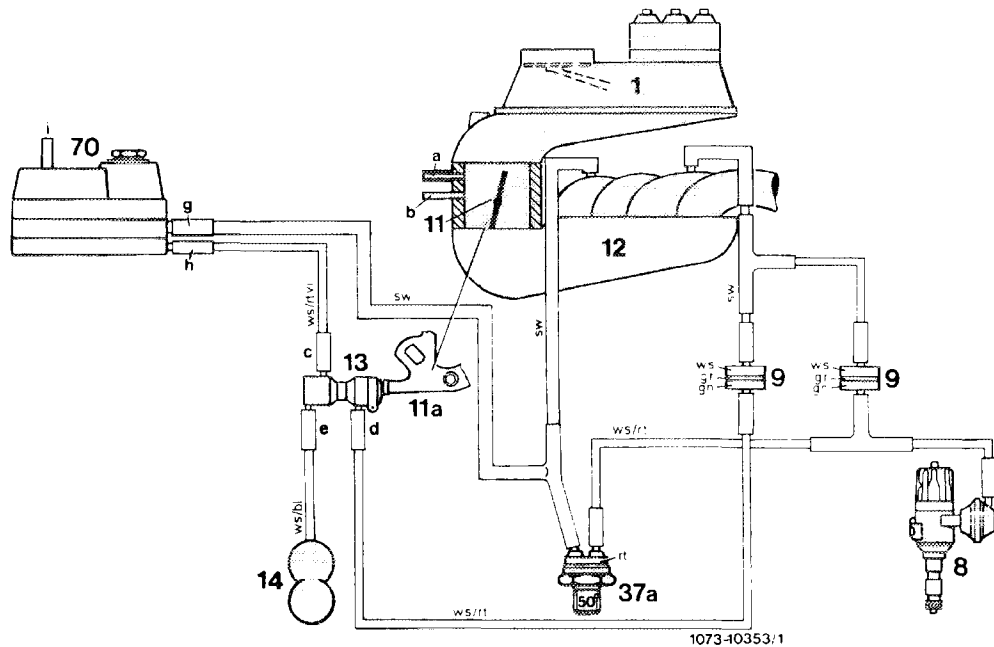

1073-10353/1

The intake manifold vacuum, which is less at full load, is acting on upper chamber (77). This will deflect the diaphragm in downward direction. The inner compression spring (73) is relieved and the force against control diaphragm (71) is reduced. The mixture is enriched.

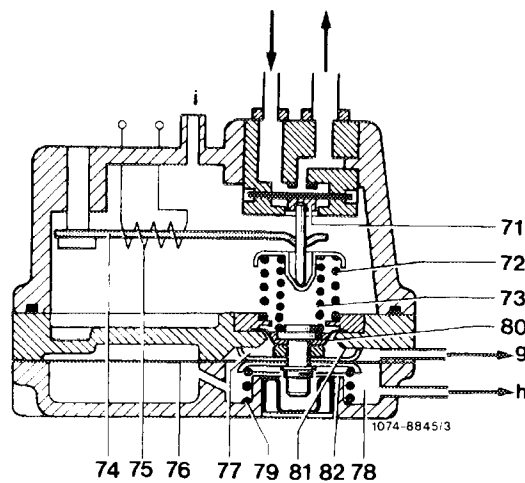

1074-8845/3

Acceleration enrichment

The acceleration enrichment is controlled in dependence of a vacuum at a coolant temperature below 50 °C (70 °C starting August 1984). There is no enrichment at higher coolant temperatures.

Two springs are exerting pressure against control diaphragm (71) in warm-up compensator, of which the outer spring (72) is firmly supported in housing and the inner spring (73) is loaded or unloaded in dependence of the vacuum.

The warm-up compensator lower half is subdivided into an upper and a lower chamber (77 and 78) by a diaphragm (76). The lower chamber holds a compression spring (79). Both chambers are subject to intake manifold vacuum.

The vacuum line of upper chamber (connection g) runs directly to intake manifold. The vacuum line of the vacuum chamber (connection h) runs via switch-over valve (13) on throttle valve housing to intake manifold. The vacuum line is provided with an orifice (9). Connections "c" and "d" of switchover valve (13) are connected to each other. Switchover operates at full throttle only (full load enrichment). In such a case, connections "e" and "c" are connected to each other.

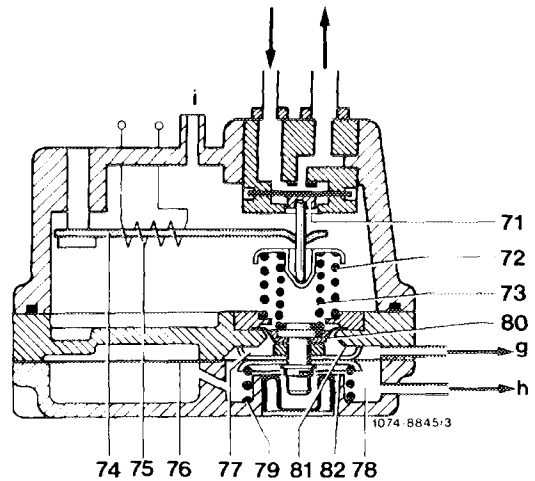

- | | |
|-----------------------|--------------------------------|
| 9 Orifice | 77 Upper chamber |
| 71 Control diaphragm | 78 Lower chamber |
| 72 Outer valve spring | 79 Compression spring |
| 73 Inner valve spring | g Connection upper chamber |
| 74 Bimetallic spring | h Connection lower chamber |
| 76 Vacuum diaphragm | i To contour hose (atmosphere) |

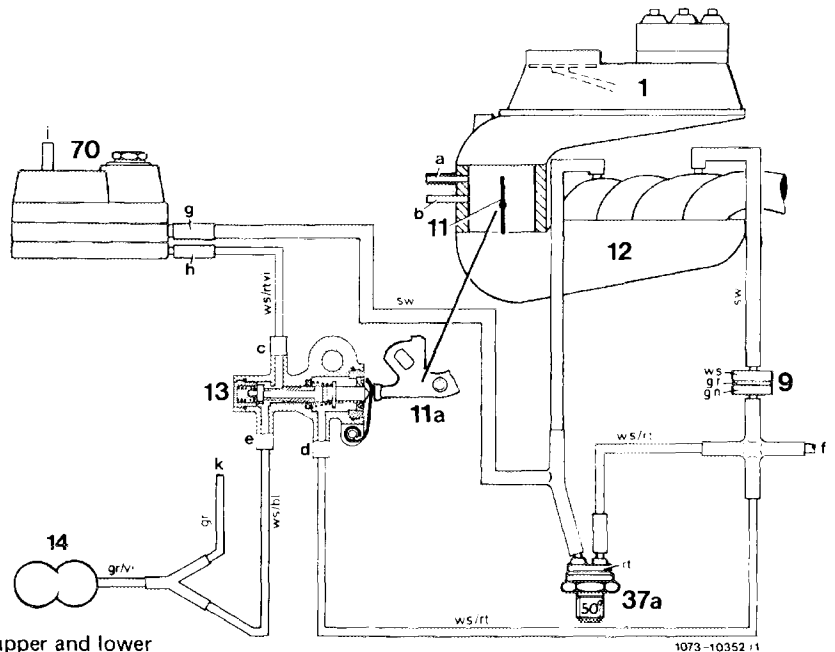

Acceleration enrichment <math>< 50\text{ }^\circ\text{C}</math>

- | |
|---------------------------------|
| 9 Orifice |
| 13 Switchover valve |
| 14 Vacuum reservoir |
| 37a Thermovalve 50 °C or 70 °C |
| f To ignition distributor |
| g Connection upper chamber |
| h Connection lower chamber |
| i To contour hose (atmosphere) |
| k Connection to intake manifold |

At constant speed the vacuum in upper and lower chamber (77 and 78) is the same. The vacuum diaphragm is resting against upper stop in vacuum chamber under influence of compression spring (79).

Upon acceleration, the vacuum in the upper chamber is reduced faster than in lower chamber under influence of orifice (9).

The vacuum diaphragm will move to lower stop.

The inner spring is relieved up to internal pressure compensation of the two chambers, so that the pressure against control diaphragm will become less. As a result of the now lower control pressure (increase of outflow cross section) a reduced force will act on control piston in fuel distributor. Consequently, the air flow sensor plate is increasingly deflected at similar air flow rate and a larger fuel quantity will be allotted (mixture enrichment).

The thermovalve (37a) opens starting at a coolant temperature of 50 °C (70 °C starting August 1984). The orifice in lower chamber will thereby be bypassed and the acceleration enrichment will be cancelled.

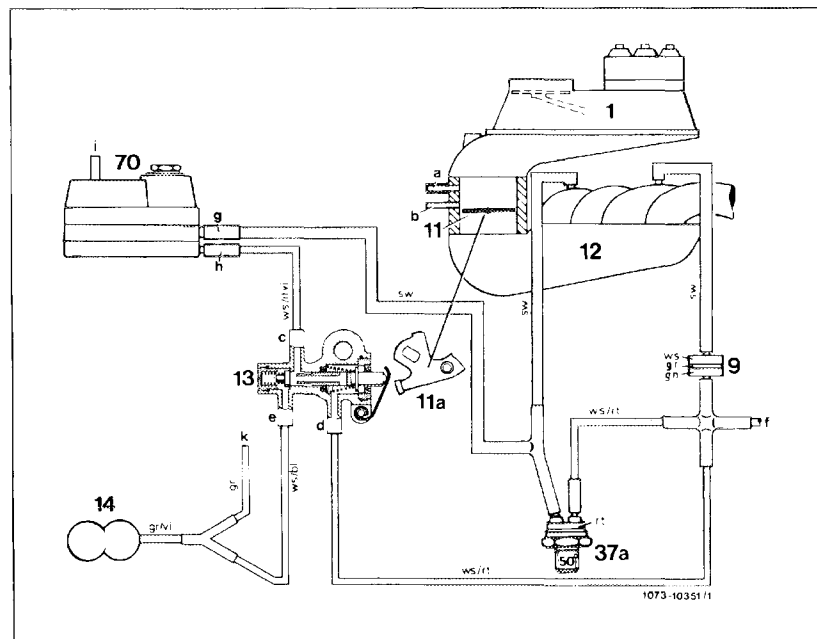

(USA) starting 1985

Acceleration enrichment is also performed when engine at normal operating temperature via pressure step switch or lambda control (refer to 14-050, Combustion II).

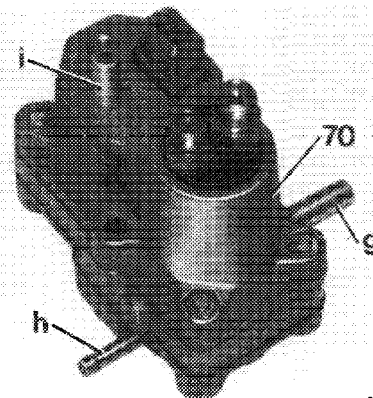

- g Connection upper chamber
- h Connection lower chamber
- i Vent
- 70 Warm-up compensator

107-16897/1

The 4 functions of warm-up compensator:

Warm-up stage

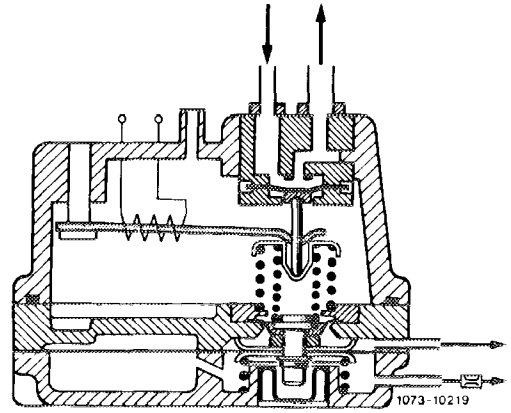

Warm-up and accelerating stage

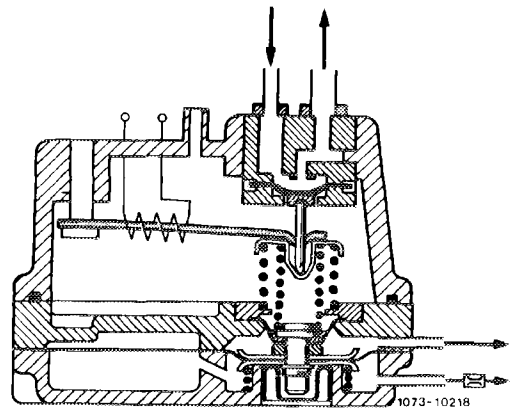

Stabilized with full load enrichment

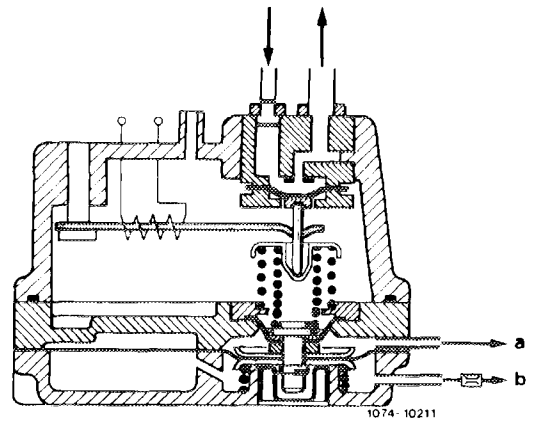

Stabilized in partial load position

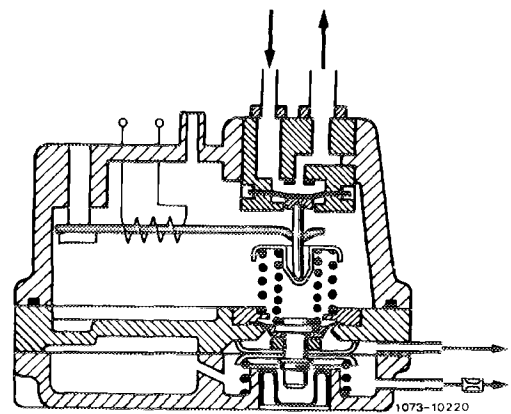

D. Electronic idle speed regulation

a) Basic version starting September 1981

National version (AUS) (CH) (S)

The idle speed is electronically controlled by means of idle speed adjuster (23). The idle speed adjuster is a lifting magnet with respective aperture which permits variation of air flow rate. The control unit provides the lifting magnet with a timed direct current in frequency range of approx. 200 Hz.

The air is picked up after the air flow sensor plate, but before the throttle valve. As a result, the respective air quantity will be combined with the respective fuel quantity via air flow sensor plate.

The control unit processes the following variables:

- Engine speed (TCI terminal TD = transistor-speed).
- Engine temperature (42 °C temperature switch in coolant circuit).
- Engaged driving position.
- Engagement of refrigerant compressor.
- Idle speed and partial load identification.

When the ignition is switched on, the magnet is set to a fundamental frequency by way of the electronic control system. The momentary engine speed is taken from the ignition impulses (TCI terminal TD) and a signal is transmitted to the idle speed adjuster. The switchover point for the engine speed is taken from temperature switch (20).

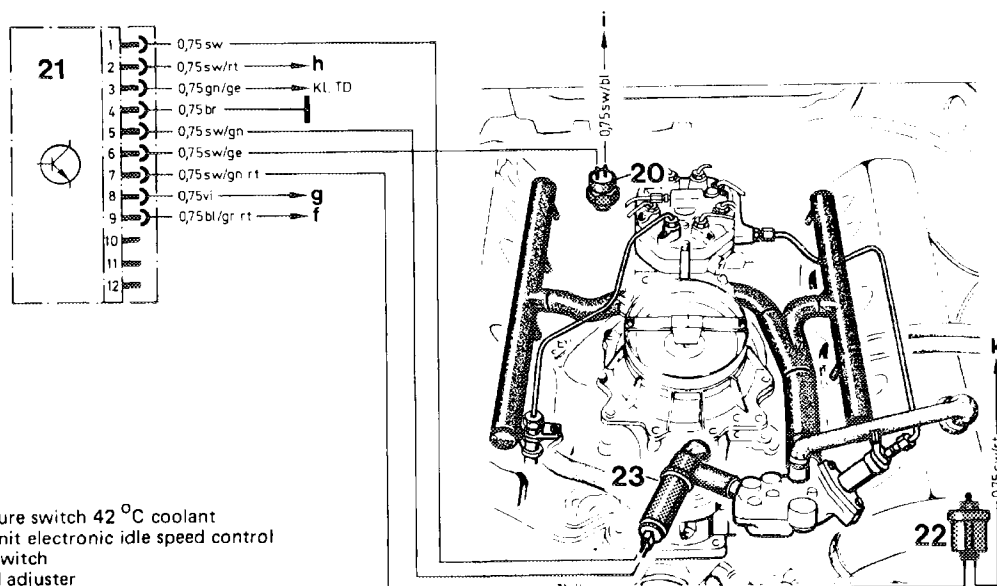

- 20 Temperature switch 42 °C coolant
- 21 Control unit electronic idle speed control
- 22 Vacuum switch
- 23 Idle speed adjuster
- f Lug, air conditioning
- g Ignition starter switch terminal 50
- h Fuse capsule terminal 15 access fuse 12
- i, k Fuse capsule terminal 15 fuse 12

1073-9719/2

b) Basic version NV KAT (closed-loop control) and national version (J) (USA)

Engine 116 model year 1981/82

The idle speed is electronically controlled by means of idle speed adjuster (23). The idle speed adjuster is a lifting magnet with respective aperture which permits variation of air flow rate. The control unit provides the lifting magnet with a timed direct current in frequency range of approx. 200 Hz.

The air is picked up after the air flow sensor plate, but before the throttle valve. As a result, the respective air quantity will be combined with the respective fuel quantity via air flow sensor plate.

Up to a coolant temperature of approx. 42 °C, the idle speed is regulated to 750/min, at a coolant temperature above approx. 42 °C, the idle speed is reduced to 500/min and kept constant.

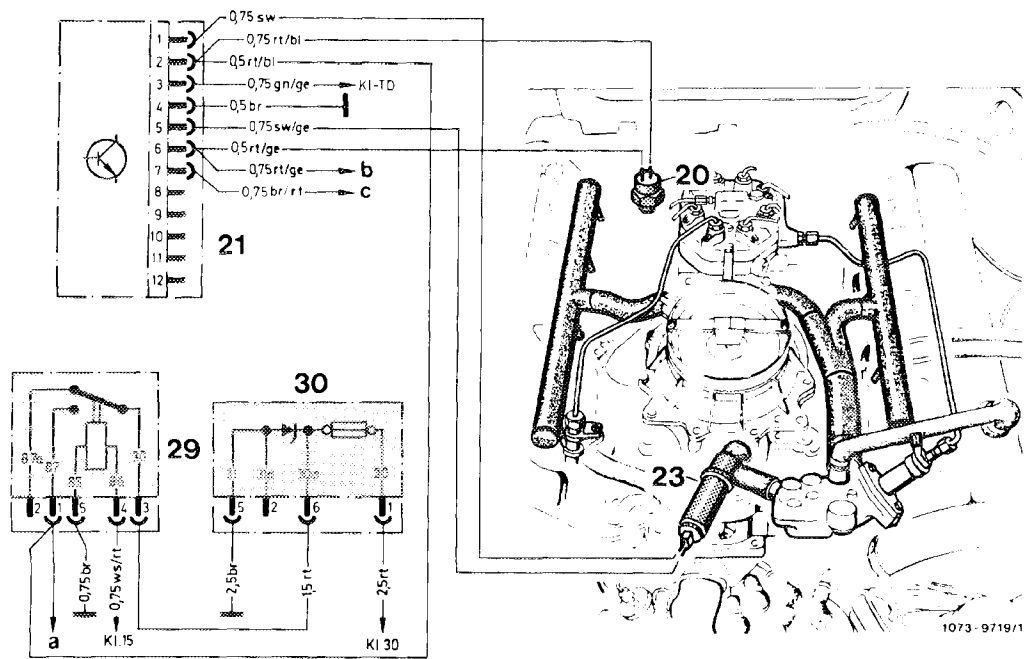

- 20 Temperature switch 42 °C coolant
- 21 Control unit electronic idle speed control
- 23 Idle speed adjuster
- 29 Relay voltage supply
- 30 Overvoltage protection

- a To control unit lambda control, terminal 8
- b To relay air injection
- c To control unit lambda control, terminal 6

When the ignition is switched on, the magnet is set to a fundamental frequency by way of the electronic control system. The momentary engine speed is taken from the ignition impulses (TCI terminal TD) and a signal is transmitted to the idle speed adjuster. The switchover point for the engine speed 750/min or 500/min is taken from temperature switch (20).

Below approx. 42 °C = 750/min
(temperature switch closed)

Above approx. 42 °C = 500/min
(temperature switch opened)

Idle speed adjuster

The idle speed adjuster has the following functions:

1. With the ignition switched off, the aperture (1) is opened to max. capacity.

- | | |
|----------------------|--------------|
| 1 Aperture | 5 Solenoid |
| 2 Piston | 6 Core |
| 3 Shaft | a Air inlet |
| 4 Compression spring | b Air outlet |

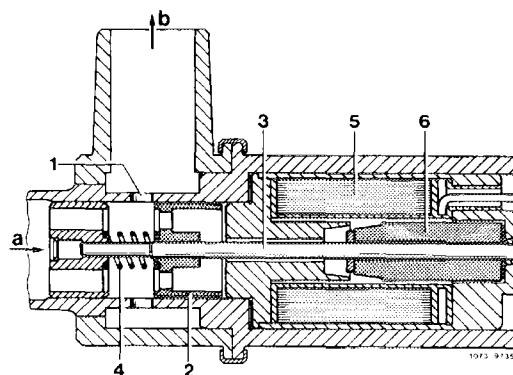

2. With the ignition switched on (engine stopped) the idle speed adjuster is activated via electronic control system with approx. 1 ± 0.5 Volt (measured at idle speed adjustment with clutch plugged on). Aperture (1) is opened to max. capacity.

3. With the engine running, the idle speed adjuster operates continuously between 4 and 5 Volts, or 1050–1200 mA. The orifice is closed approx. 5 Volts.

A slight leak air rate is permitted.

4. At a speed above 900/min, the idle speed adjuster is activated with approx. 4.5 Volts, so that the aperture is partially opened. This will prevent stopping of engine in the event of a fast rpm drop.

- | | |
|----------------------|--------------|
| 1 Aperture | 5 Solenoid |
| 2 Piston | 6 Core |
| 3 Shaft | a Air inlet |
| 4 Compression spring | b Air outlet |

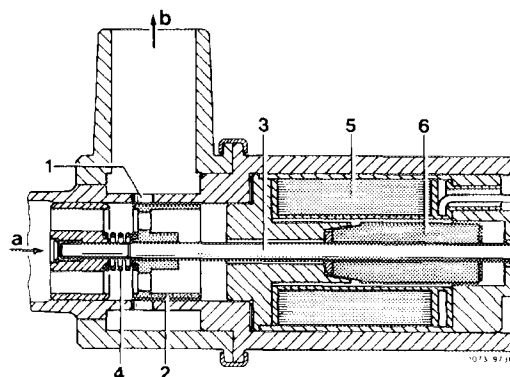

Engine 116 starting model year 1983
Engine 116 basic version NV KAT (closed-loop control), starting 1984
Engine 117 starting model year 1984

The electronic idle speed control has been modified. The switchover point for engine speed is picked up at temperature switch 16 °C oil (19), which transmits simultaneously a signal to the control unit of lambda control.

The new control unit processes the following variables:

- Engine speed.
- Idle speed and partial load identification.
- Engine oil temperature.
- Engaged driving position.
- Engagement of refrigerant compressor.

Four idle speeds will result depending on operating condition and engine oil temperature.

Driving position	Engine oil temperature	Idle speed
With gear step not engaged	< 16 °C	800–950/min
	> 16 °C	600–700/min
With gear step engaged	< 16 °C	650–750/min
	> 16 °C	450–550/min

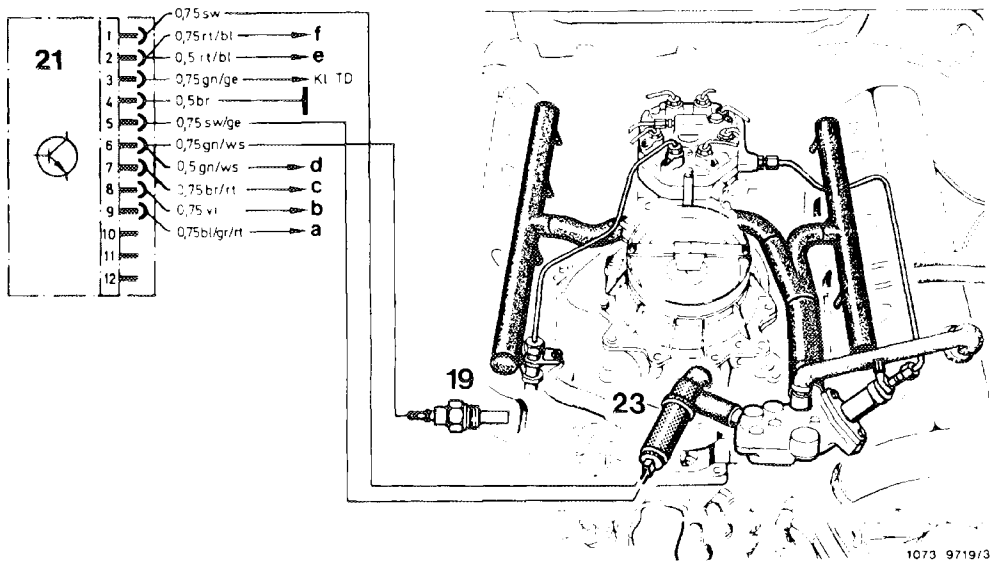

Function diagram

- 19 Temperature switch 16 °C oil
- 21 Control unit for electronic idle speed control
- 23 Idle speed adjuster

- a To lug (a) automatic climate control
- b To ignition starter switch terminal 50
- c To control unit lambda control terminal 6

- d To control unit lambda control terminal 7 looped to throttle valve switch
- e To relay lambda control with overvoltage protection
- f To temperature switch 42 °C coolant

Functional description of control unit

When the ignition is switched on, the magnet of the idle speed adjuster is put into a basic frequency via control electronics of control unit. The momentary engine speed is derived from ignition impulses (terminal TD) and a signal is transmitted to idle speed adjuster.

The idle speed adjuster has the following functions:

1. With the ignition switched off, the aperture (1) is opened to max. capacity.

- | | |
|----------------------|--------------|
| 1 Aperture | 5 Solenoid |
| 2 Piston | 6 Core |
| 3 Shaft | a Air inlet |
| 4 Compression spring | b Air outlet |

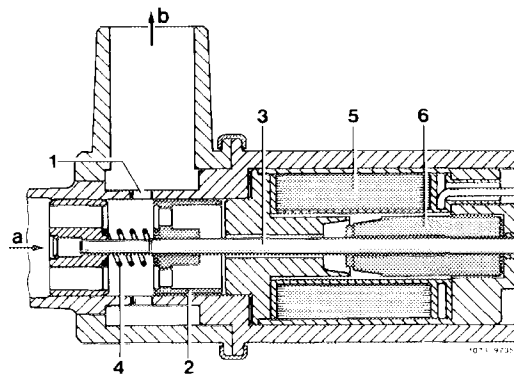

2. At idle (without additional consumers) the idle speed adjuster operates with currents higher than 400 mA.

Idle speed and partial load identification

With the throttle valve slightly opened, the idle speed adjuster is provided with a speed of approx. 850 rpm via throttle valve switch and control unit. When the throttle valve is quickly closed, the engine speed cannot drop below 450 rpm.

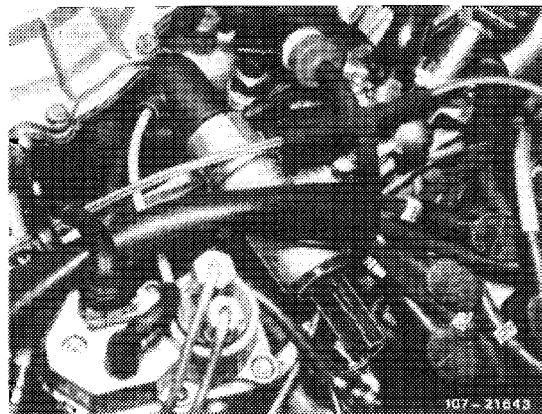

When 850 rpm are exceeded, the current increases proportionally with the speed up to approx. 1000/ rpm; above that number the air flow rate is constant.

Idle speed stabilization when switching on refrigerant compressor (at normal operating temperature)

A delay valve (28, arrow) has been installed instead of alternating contact relay for activating the magnetic clutch of the refrigerant compressor. As a result, the control unit (21) will be activated prior to adding the refrigerant compressor (refer to group 83, electric wiring diagram).

Model 107

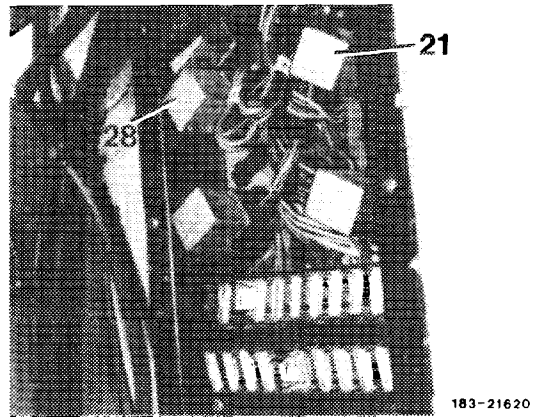

Prior to the increased engine load caused by including the refrigerant compressor, the idle speed adjuster opens to the extent that the engine continues running smoothly.

Model 126

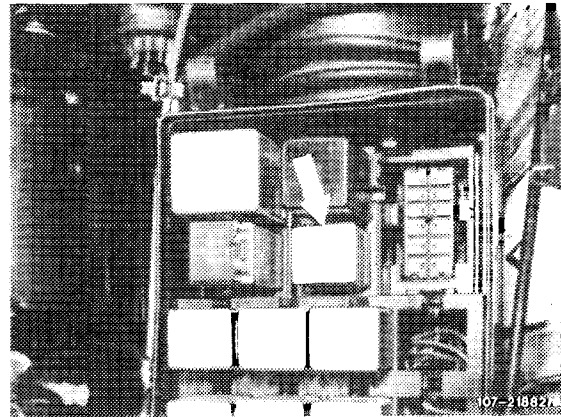

Lowering of idle speed when engaging a driving position (at normal operating temperature)

The starter lockout switch is closed in selector lever position "P" or "N". In such a case, terminal 8 of control unit (21) is connected to ground via coil of starter solenoid switch.

Model 107

21 Control unit at the right in vehicle interior under cover

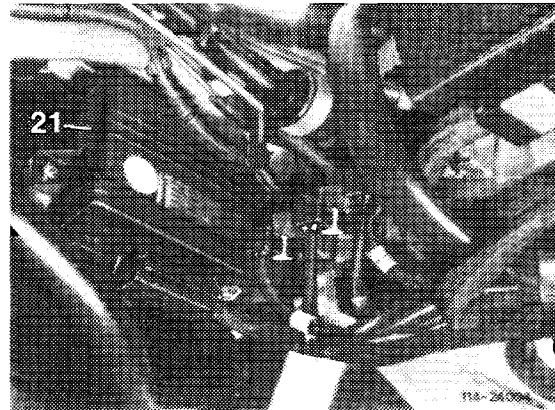

With driving position engaged, the starter lockout switch is opened and the ground connection is interrupted. The regulated speed changes from approx. 650 rpm to aprox. 500 rpm.

Model 126

21 Control unit in unit compartment

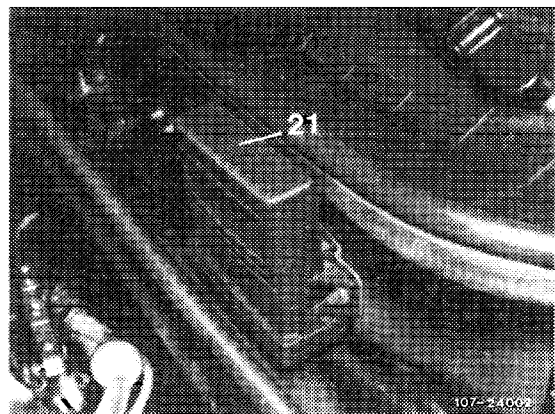

E. Fuel pump relay

The fuel pump relay for voltage supply of fuel pump has three, respectively four functions:

1. Activation of fuel pump when starting or with engine running.

The warm-up compensator is also activated in parallel with fuel pump.

2. Rpm limitation after attaining max. engine speed.
3. Switching-off of fuel pump as soon as no more impulses are arriving via terminal TD of switching unit.

TD = Transistor speed signal.

4. Kickdown shutoff.

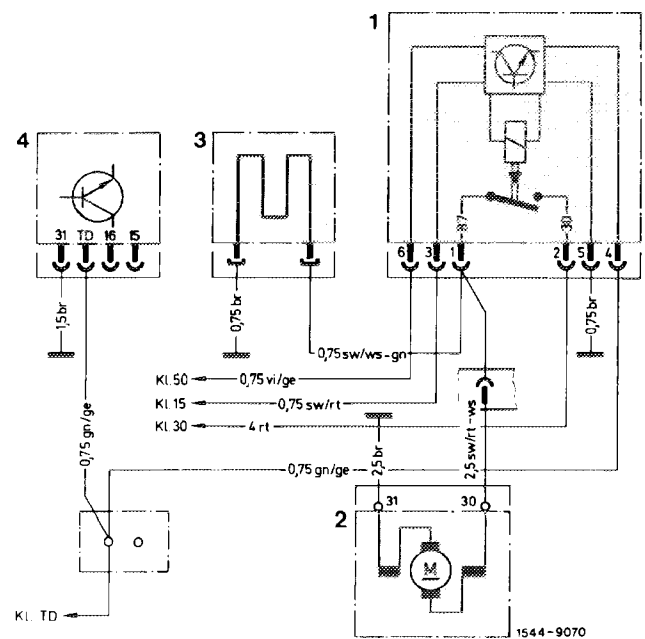

Wiring diagram prior to September 1981

- 1 Fuel pump relay
- 2 Fuel pump
- 3 Warm-up compensator
- 4 Switching unit (TCI)

1. Activation of fuel pump when starting and with engine running

When starting, the fuel pump relay is activated via terminal 50 and with the engine running via terminal TD of ignition switching unit.

While starting, the fuel pump relay is activated via terminal 50, because the respective parallel activation of fuel pump relay via terminal TD at engine speeds below approx. 80/min is not enough. The impulse sequence of terminal TD is too low to keep contacts 30–87 in pump relay constantly closed.

At speeds above approx. 80/min, the frequency of the impulses is high enough to keep contacts 30–87 in fuel pump relay constantly closed.

The warm-up compensator is also activated in parallel with fuel pump.

2. Rpm limitation after attaining max. engine speed

When a given impulse sequence in accordance with max. engine speed is attained, the contacts 30–87 for fuel pump are interrupted. The fuel pump is deenergized, and switches off.

Owing to the electronic rpm control, the rpm control on distributor rotor may be discarded. On engines 116.961, 117.961 the rpm control on distributor rotor is temporarily maintained, because the ignition distributors are identical with those of gray iron engines 116, 117.

3. Switching-off of fuel pump as soon as no more impulses are transmitted via terminal TD of switching unit

One second after the last impulse from terminal TD, the contacts 30–87 in fuel pump relay are interrupted as a safety measure. Pump is deenergized and switches off.

4. Kickdown shutoff

During acceleration at kickdown the magnetic valve is energized by kickdown switch (5).

The activation of the magnetic valve of kickdown switch (5) is routed via fuel pump relay with kickdown shutoff (13).

200/min prior to breakaway speed of engine, the fuel pump relay (13) interrupts the current supply to magnetic valve and the transmission will shift to next gear step.

This will make sure that the shifting proceeds prior to attaining breakaway speed.

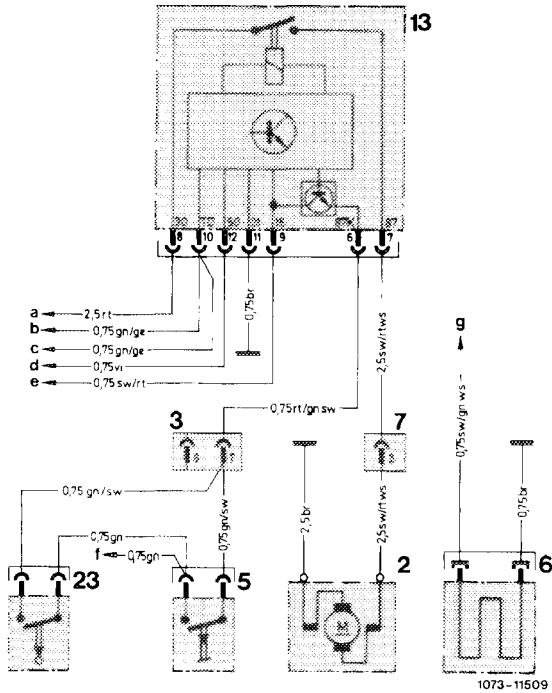

1073-11509

Wiring diagram starting September 1981

- 2 Fuel pump
- 3 Clutch 8-pole
- 5 Kickdown switch
- 6 Warm-up compensator
- 7 Connector, tail lamp harness
- 13 Fuel pump relay
- 23 Switch selector position "B"

- a Lug, terminal 30
- b Cable connector terminal TD
- c Control unit electronic idle speed control
- d Cable connector engine terminal 50
- e Fuse capsule terminal 15 access fuse 14
- f Magnetic valve automatic transmission
- g Model 107: Connector, tail lamp harness (7) 14-pole jack 2
- Model 126: Fuel pump relay (13) terminal 87 jack 7

- Line colors
- br = brown
 - ge = yellow
 - gn = green
 - rt = red
 - sw = black
 - vi = purple
 - ws = white