

Special tool

Puller for impeller

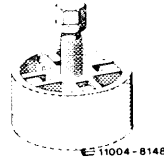

100 589 15 33 00

Self-fabricated tools

Pressing-in sleeve

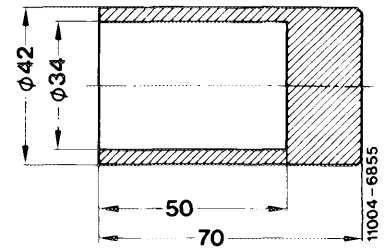

Tester for tight fit of impeller

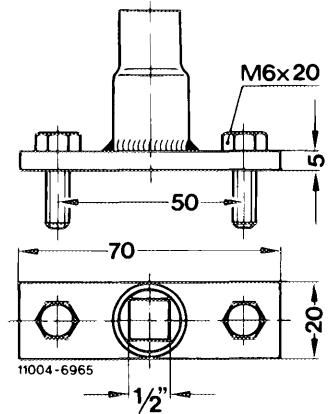

- 1 Flange
 - 2 Coolant pump shaft with compact bearing
 - 3 Coolant pump housing
 - 4 Sliding ring seal
 - 5 Counter-ring with sealing ring
 - 6 Impeller
 - 7 Dowel sleeve
- a 5.3–5.7 mm
c Vent bores

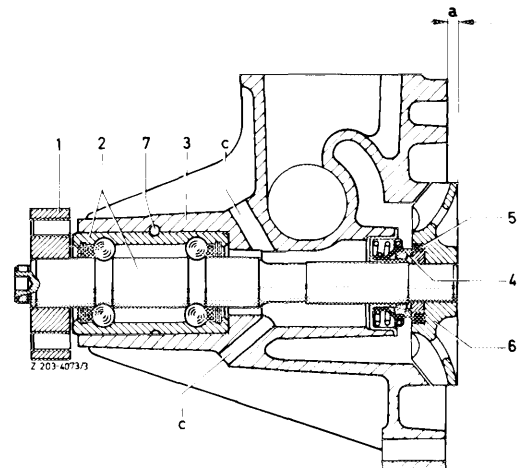

Note

In October 1982 a modified sliding ring seal was temporarily installed in the coolant pump.

In the event of repairs, the parts must be installed according to the spare parts microfilm. The sliding ring seal must be renewed together with the counter-ring in the impeller in this case.

Modified sliding ring seal

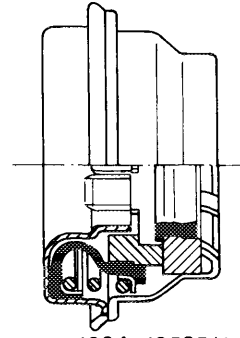

1204-10595/1

Production breakpoint: October 1982

Model	Engine	Engine end No.	Chassis end No.
107.045	116.962	010568-011371	020008-020813
107.046	117.962	001409-001513	002344-002447
126.032/033	116.963	019968-021578	036525-037774
126.036/037	117.963	016596-017767	026056-026924
126.043	116.963	019968-021578	004095-004435
126.044	117.963	016596-017767	003634-003893

Disassembly

1 Pull off impeller.

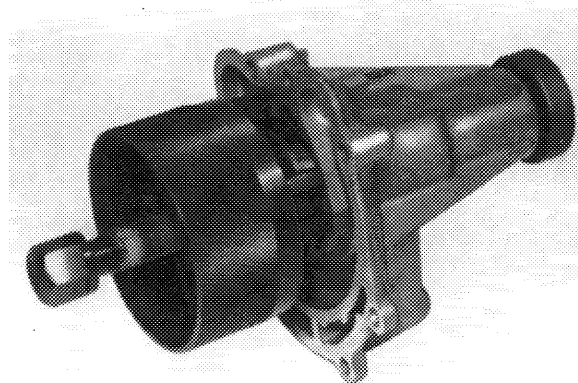

082-16132

2 Cancel preload at several points by means of light hammer blows between coolant pump housing and sliding ring seal and push out sliding ring seal.

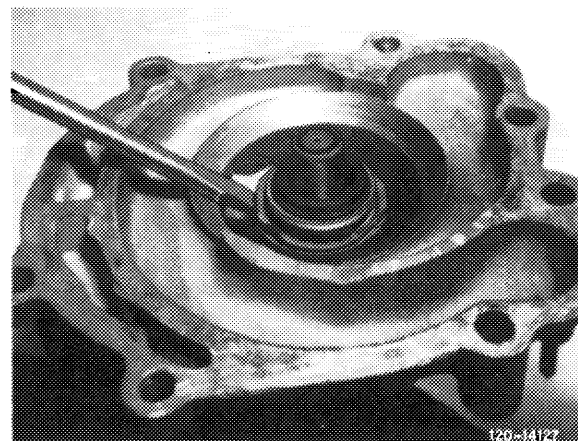

120-14127

3 Force counter-ring out of impeller.

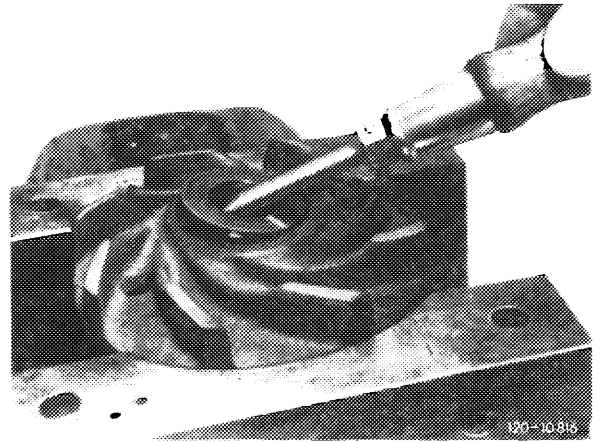

Assembly

4 Lightly coat housing jacket of sliding ring seal with sealing compound and drive or press sliding ring seal into bearing housing by means of pressing-in sleeve.

Caution!

Support at bearing housing only and not at coolant pump shaft.

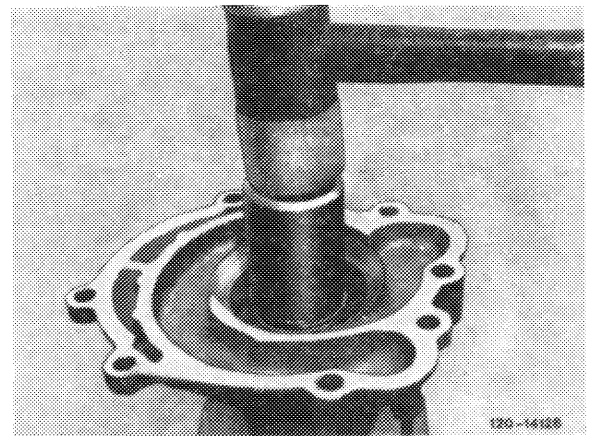

5 Coat sealing ring on counter-ring with brake cylinder paste and push counter-ring with chamfered side (arrow) into carefully cleaned mounting bore of impeller.

6 By means of a chamois leather, remove all dust from the sealing surface of the counter-ring and sliding ring seal.

7 Grease shaft stub of coolant pump shaft and bore in impeller.

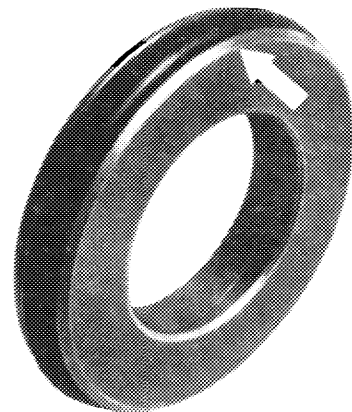

8 Press on impeller while supporting the coolant pump shaft.

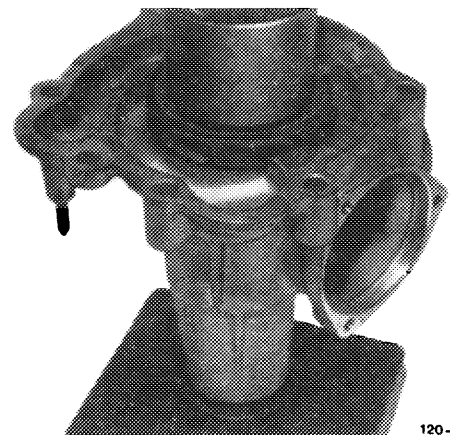

9 Check impeller for tight seat, nominal torque minimum 35 Nm.

