





05–250 Removal and installation of valve springs

Valve clearance	with engine cold (approx. 20 °C)	with engine warm (60 °C ± 15 °C)
Intake	0.10 ¹⁾	0.15 ¹⁾
Exhaust	0.20	0.25

¹⁾ 0.05 mm higher during lasting outside temperatures below –20 °C.

Tightening torques	Nm
Bolts for cylinder head cover	3
Valve adjusting screw	20–40

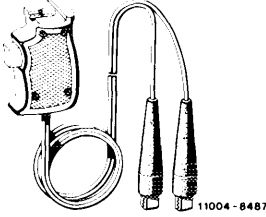
Special tools

Valve spring depressor		123 589 03 61 00
Magnetic lifter for valve cone halves		116 589 06 63 00
Contact handle for rotating engine (component of compression meter) 001 589 46 21 00		001 589 46 21 08
Valve adjusting wrench 17 mm		116 589 02 01 00

Conventional tool

Cylinder leak tester	e. g. made by Bosch, EFAW 210 A made by SUN, CLT 228–1
----------------------	---

Removal

1 Remove rocker arm (05–230).

Attention!

Install rocker arm at the same spot as before.

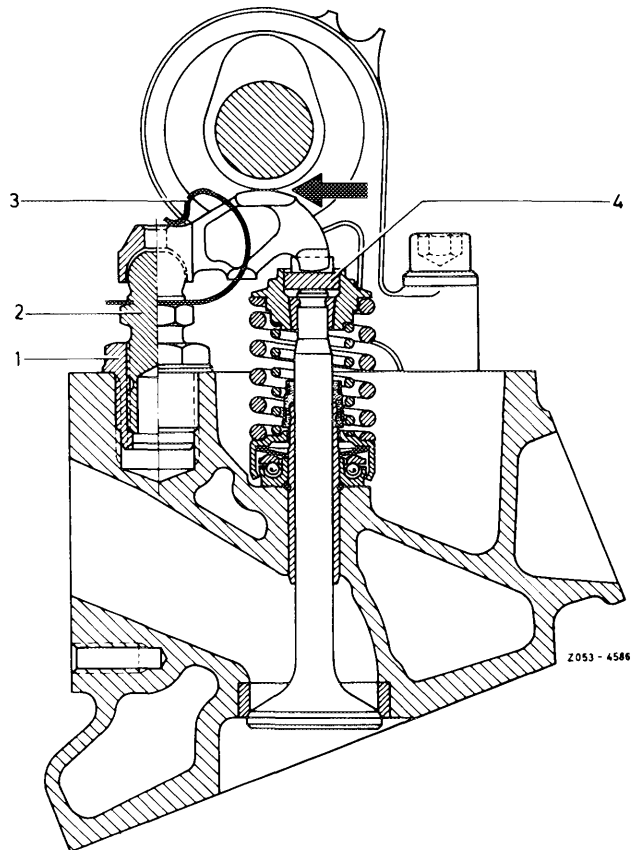

2 Unscrew spark plugs.

3 Set piston of respective cylinder to ignition TDC. For this purpose, rotate engine with tool combination and crankshaft.

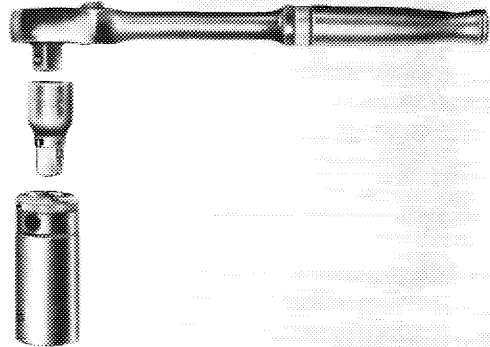

Note: The markings 0, 90, 180 and 270 (arrows) are punched into vibration damper.

At the positions shown below in relation to needle the following pistons are at TDC:

Marking number	Piston at TDC
0	1 and 6
90	5 and 3
180	4 and 7
270	8 and 2

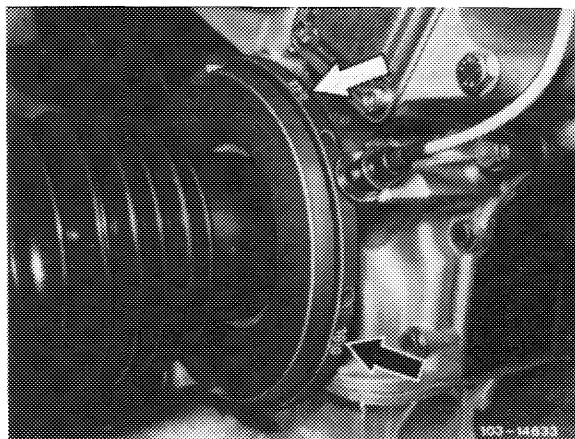

4 Support valve by compressed air (cylinder leak test).

Attention!

Valves should not rest on piston crown to prevent bending of valves.

5 Push valve spring retainer down by means of lever-type pusher.

6 Remove valve cone halves with magnetic lifter.

7 Remove valve spring retainer and valve spring.

8 Check valve spring, renew according to condition (05–260).

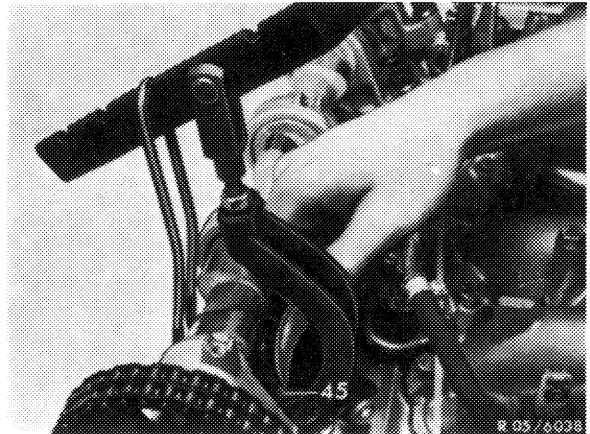

Installation

9 Insert valve spring with close coils toward cylinder head.

10 For further installation proceed vice versa to removal.

11 Adjust valve clearance (05–210).

- 1 Thrust pieces
- 2 Valve cone
- 3 Valve spring retainer
- 4 Valve spring, outer
- 5 Valve spring, inner
- 6 Rotocap
- 7 Valve seal intake
- 8 Valve seal exhaust
- 9 Locking ring intake
- 10 Locking ring exhaust
- 11 Valve guide intake
- 12 Valve guide exhaust
- 13 Intake valve
- 14 Exhaust valve
- 15 Tensioning spring
- 16 Rocker arm
- 17 Adjusting screw
- 18 Threaded bushing
- 19 Hydraulic valve clearance compensating element

