

05-340 Removal and installation of slide rails

Tightening torques	Nm	(kpm)
Bolts for cylinder head cover	3	(0.3)
Necked-down screw on crankshaft front	270-330	(27-33)
Fastening screw for camshaft sprocket	100	(10)

Special tools

Impact puller for bearing bolt
(basic unit)

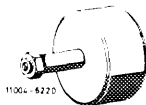

116 589 20 33 00

Threaded bolt 6 x 50 mm



116 589 01 34 00

Detent
(starter flange)

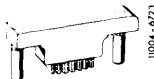

116 589 01 40 00

Torque wrench
150-500 Nm



001 589 31 21 00

Socket 27 mm, 1/2" square



001 589 65 09 00

Conventional tool

Connection 3/4" square socket
to 1/2" square head

e.g. Hazet, D-5630 Remscheid
order No. 1058 RI

Note

All slide rails in cylinder heads of all engines 116 are similar in design.

Slide rails in cylinder heads of all engines 117 are likewise identical.

On the other hand, the pertinent bearing bolts of light alloy engines differ from those of gray iron engines in length.

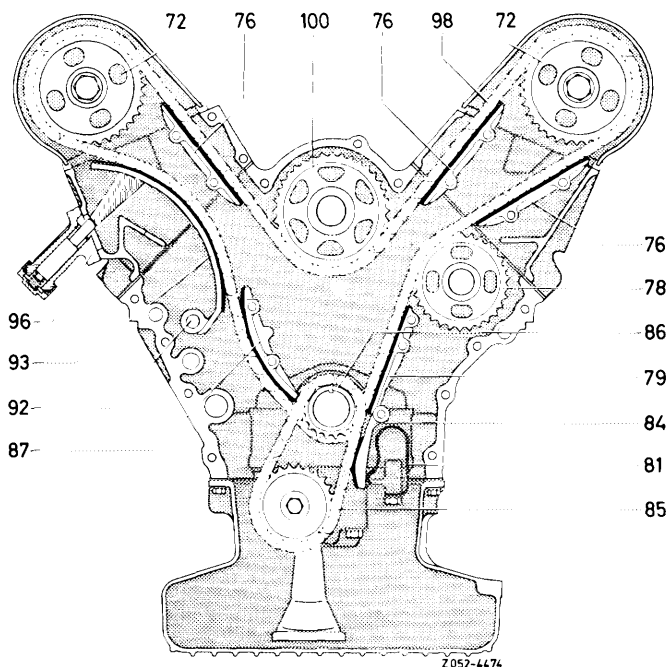

Slide rails in cylinder head left inside and outside

- 1 Set piston of 1st cylinder to ignition TDC.
- 2 Remove ignition distributor (07.5–510).

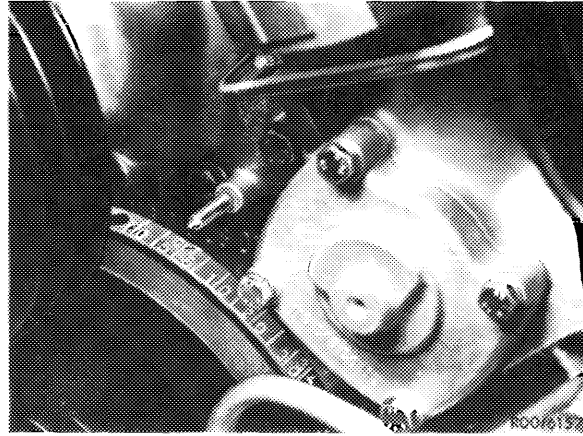

- 3 Remove power steering pump with mounting bracket.
- 4 Knock out bearing bolt with impact puller and remove slide rail.

- 5 When installing slide rail, note the following:

Bearing bolts differ from those of gray iron engines.

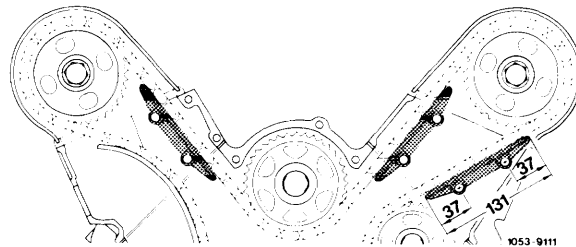

Slide rail layout engine 116

Light alloy engines L = 46 mm
Gray iron engines L = 56 mm

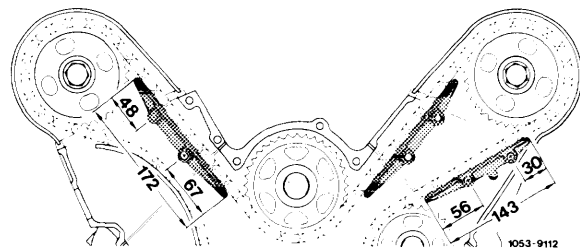
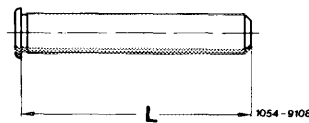

Slide rail layout engine 117

Light alloy engines L = 46 mm
Gray iron engines L = 56 mm



Slide rail in cylinder head right

- 1 Remove alternator with mounting bracket.

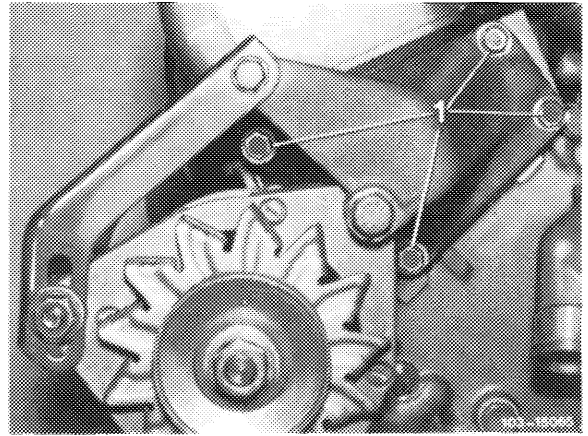

- 2 Knock out bearing bolt with impact puller and remove slide rail.

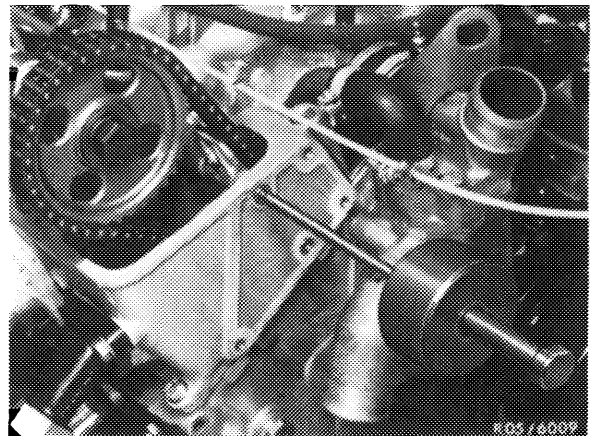

Slide rails in cylinder crankcase

- 1 Remove timing housing cover.
- 2 Unscrew slide rail (87 or 79).

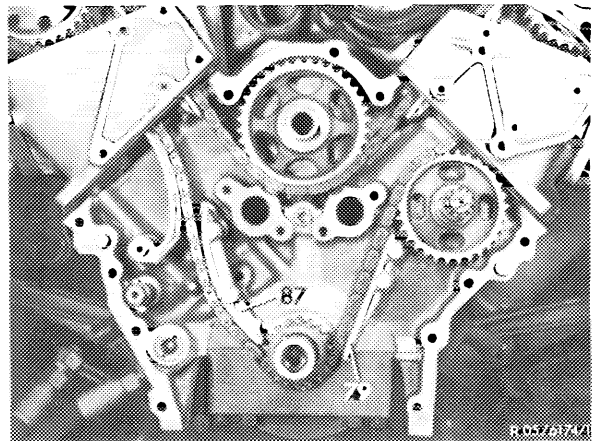

The two slide rails in cylinder crankcase differ from those of gray iron engines.

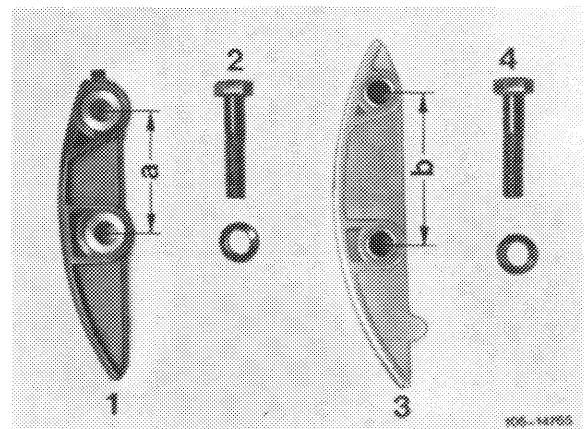

Engine 116.96, 117.96

- 1 Slide rail
- 2 Screw M 8 x 40
- a 43.8 mm

Engine 116.98, 117.98

- 3 Slide rail
- 4 Screw M 8 x 38
- b 55 mm

Attention!

If on engine 116.98 version 1 is exchanged for version 2 or 3, remove stop sleeve from chain tensioner 116 05 10 11.

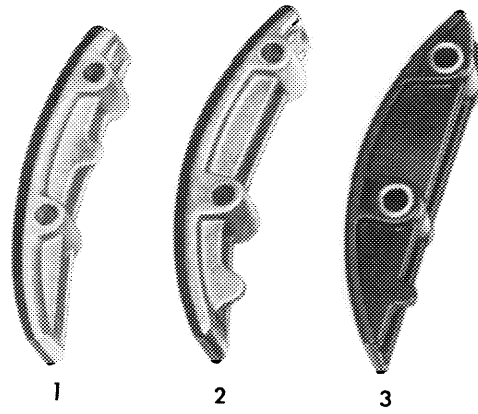

- 1 Invalid slide rail
- 2 Former slide rail
- 3 New slide rail

105-9659

The straight slide rail (1) in cylinder crankcase is unsymmetrical (arrow) and is plugged on bolts (2) screwed into cylinder crankcase.

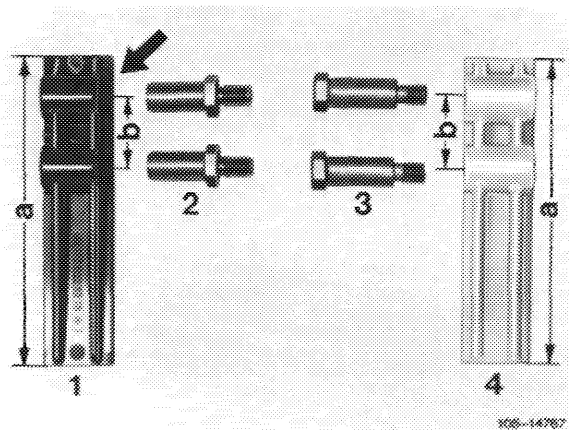

- 1, 2 Engine 116.96 and 117.96
- 3, 4 Engine 116.98 and 117.98
- a 114 mm
- b 26 mm

105-14787

Tensioning clamp for oil pump chain

- 1 Remove timing housing cover.
- 2 Remove lock and remove tensioning clamp (84).

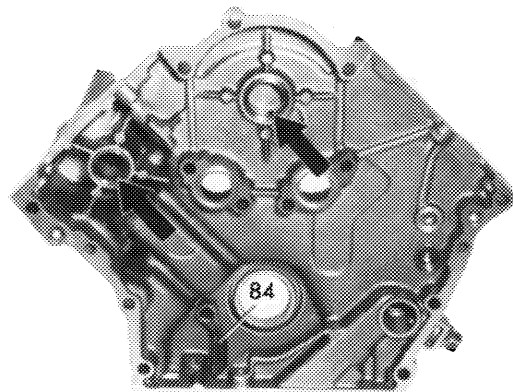

103-9559/1