

22–210 Removal and installation of engine mounts

Engine 116.982/992, 116.984, 117.982/992, 117.985

Engine mount front

- 1 Unscrew screw (6).
- 2 Turn holder (8) in lateral direction and remove shielding plate (9).

- 3 Lift engine at oil pan by means of pit lift.

Note: Use wooden shim to avoid damaging oil pan.

- 4 Unscrew engine carrier on engine and remove.
- 5 Unscrew engine mount on front axle carrier and remove.

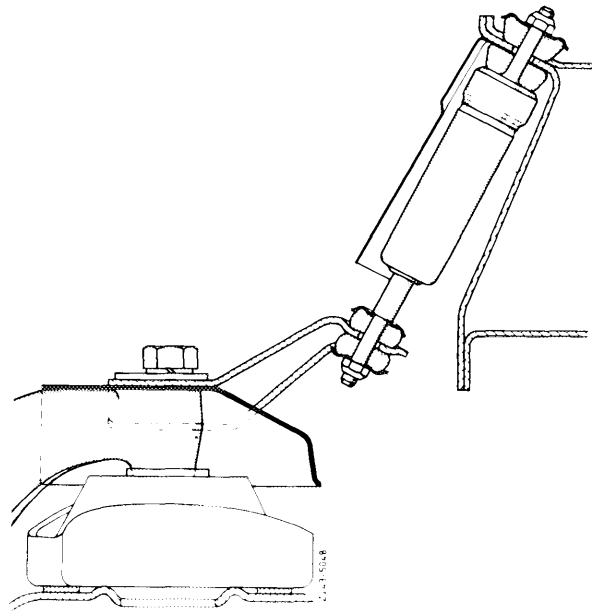

6 For installation proceed vice versa.

7 Tighten screw (6) to 75 Nm.

Attention!

Check regulating linkage for function.

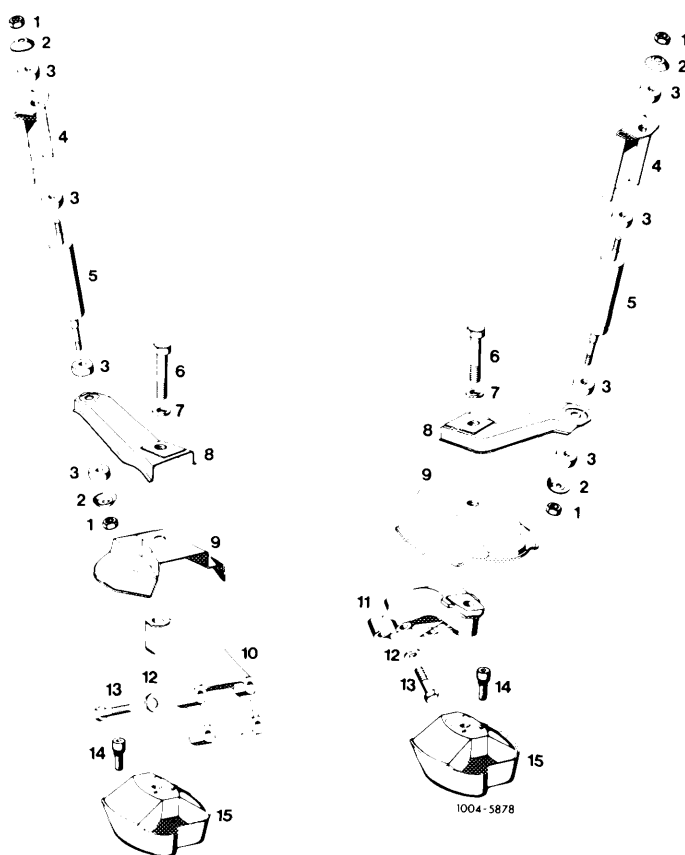

- | | |
|-------------------------|-------------------------|
| 1 Nut | 9 Shielding plate |
| 2 Disc washer | 10 Engine carrier right |
| 3 Rubber buffer | 11 Engine carrier left |
| 4 Shielding plate | 12 Washer |
| 5 Engine shock absorber | 13 Screw |
| 6 Fastening screw | 14 Combination screw |
| 7 Spring washer | 15 Engine mount |
| 8 Holder | |

Engine mount rear

Attention!

Do not unscrew closing plate for removing engine mount (4).

During installation, attach engine mount to closing plate free of tension.

Upon installation of engine mount, loosen adjusting screw (8), run engine for a short moment at idle. With the engine stopped, tighten adjusting screw (8) to 25 Nm.

Attention!

Check regulating linkage for function.

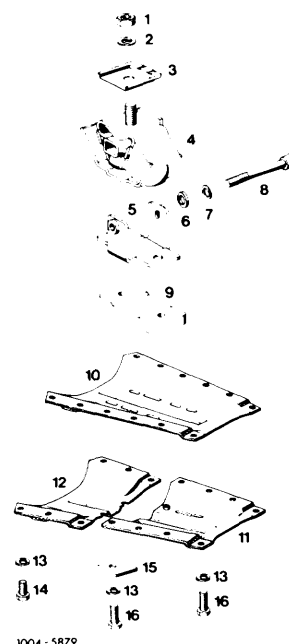

- | | |
|----------------------------|---|
| 1 Nut M 12 x 1.5 | 10 Closing plate manual transmission |
| 2 Spring washer B 12 | 11 Closing plate automatic transmission |
| 3 Holding plate | 12 Closing plate automatic transmission |
| 4 Holder | 13 Snap ring A 8 |
| 6 Washer 8.4 | 14 Screw M 8 x 20 |
| 7 Snap ring A 8 | 15 Shim |
| 8 Adjusting screw M 8 x 75 | 16 Screw M 8 x 32 |
| 9 Shim | |

Engine 116.980/990, 116.981/991, 117.981, 117.984

Engine mount front

- 1 Unscrew lefthand engine shock absorber on upper suspension.
- 2 Unscrew righthand engine shock absorber on lower suspension.
- 3 Unscrew screw for engine carrier on engine mount.
- 4 Lift engine at oil pan with pit lift.

Note: Use wooden shim to avoid damaging oil pan.

When lifting engine, make sure that the breather is not caught at radiator shell.

On vehicles with air suspension, observe notes concerning assembly jobs (workshop manual "Passenger car models starting 1968", job No. 32-11).

5 Unscrew engine mount on front axle carrier and remove.

6 For installation proceed vice versa.

Attention!

Check regulating linkage for function.

Engine mount rear

1 Unscrew hex. nut for engine mount on transmission.

2 Disconnect brake cable at front and take out of cable guide.

3 Unscrew engine mount from engine carrier.

4 Lift engine at transmission with pit lift.

5 Unscrew engine carrier and remove engine mount.

6 For installation proceed vice versa.

Attention!

Check regulating linkage for function.

Engine 116.983/993, 116.985, 117.983/993, 117.986

Engine mount front

1 Unscrew screw for engine carrier on engine mount (arrow).

2 Loosen engine shock absorber on front axle carrier.

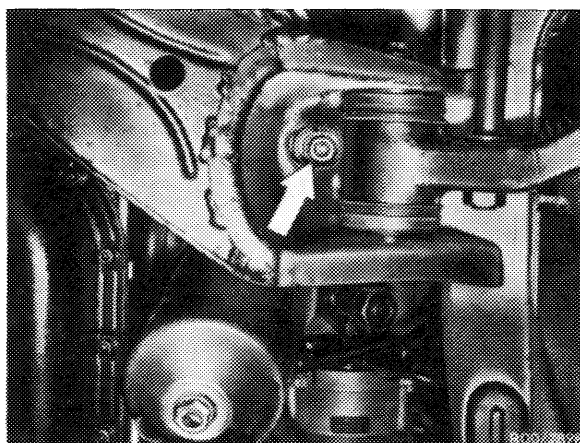

3 Lift engine at oil pan with pit lift.

Note: Use wooden shim to avoid damaging oil pan.

4 Unscrew engine carrier on engine and remove together with engine shock absorber and shielding plate.

5 Unscrew engine mount on engine carrier and remove.

6 For installation proceed vice versa.

Attention!

Snap ring (arrow) should not be too large.

Check regulating linkage for function.

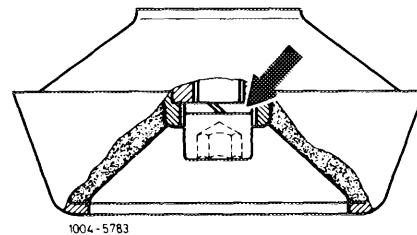

Engine mount rear

Attention!

Do not unscrew engine carrier (6) for removing engine mount (4).

Check shim (5) for correct installation position.

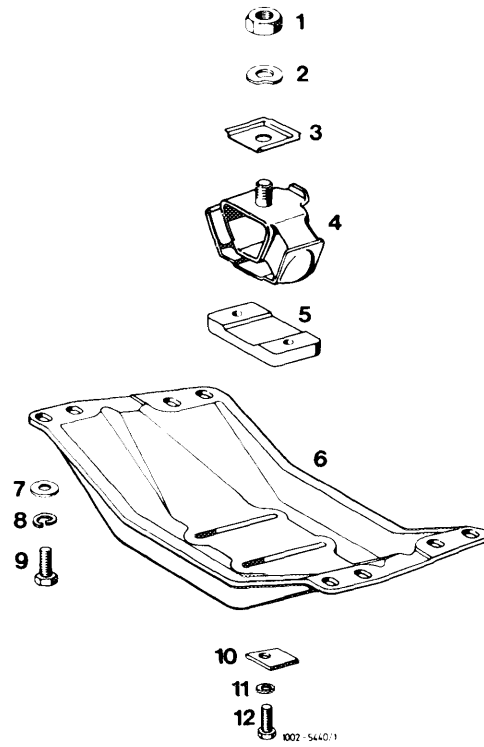

- | | |
|------------------|--------------|
| 1 Nut M 12 x 1.5 | 7 Washer |
| 2 Spring washer | 8 Snap ring |
| 3 Holding plate | 9 Screw |
| 4 Engine mount | 10 Shim |
| 5 Shim | 11 Snap ring |
| 6 Engine carrier | 12 Screw |