

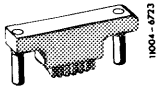

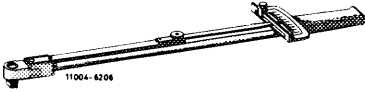
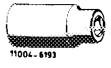

Tightening torques		Nm
Crankshaft end bolt	with 3 diaphragm springs ¹⁾	270 – 330
	with 4 diaphragm springs ¹⁾	370 – 400

¹⁾ See Note 03–324.

Special tools

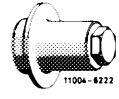
Detent for counterholding crankshaft		116 589 01 40 00
Torque wrench 150–500 Nm		001 589 31 21 00
Socket insert 27 mm		001 589 65 09 00
Screwdriver for hexagon socket head screws 6 mm, 440 mm long		116 589 03 07 00
Installing tool for radial sealing ring		110 589 07 61 00
Installing tool for oil dipstick guide tube		117 589 00 31 00

Conventional tool

3/4" inside to 1/2" outside square drive adapter

e.g. Hazet, D–5630 Remscheid
Order No. 1058 RI

Notes

The timing case covers of engines 116 and 117 are distinguished by casting number and height.

Two through-holes each for the heater return (1) and the coolant supply (2) are arranged on the timing case cover. These are sealed at the crankcase by means of rubber sealing rings.

Because of the modified hole pattern for the water pump, the timing case covers cannot be used on cast iron engines.

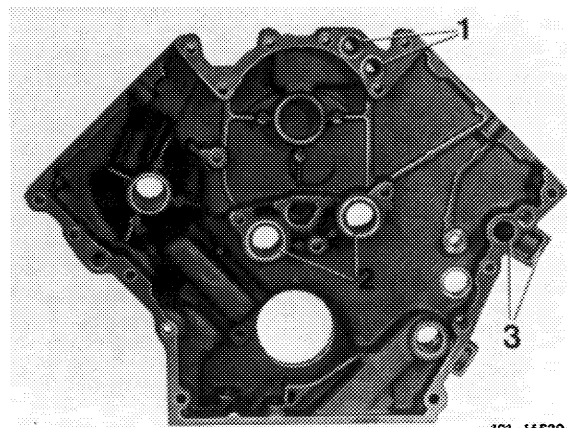

101–14639/1

On engines without oil cooler, the thread (arrow) for the temperature switch on the timing case cover (only turbocharged engines) were changed from M 16 x 1.5 to M 14 x 1.5.

The timing case cover can be removed with the cylinder heads installed if care is exercised not to damage the cylinder head gasket.

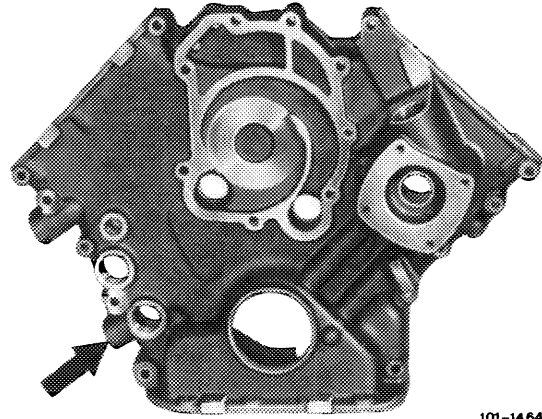

101-14 640/2

Removal

- 1 Disconnect ground strip from battery.
- 2 Drain engine oil and coolant.
- 3 Remove radiator, fan cover and viscofan.
- 4 Remove alternator with bracket.
- 5 Remove distributor.
- 6 Remove power steering pump with pipes connected and set aside.
- 7 Remove V-belt pulley together with vibration damper and hub (03-342).

Crankshaft arrangement 2nd version

- 1 V-belt pulley
- 2 Bolt M 8 x 22
- 3 Vibration damper
- 4 Bolt M 18 x 1.5 x 45
- 5 Diaphragm springs (4)
- 6 Hub
- 7 Radial sealing ring
- 8 Woodruff key
- 9 Timing case cover
- 10 Crankshaft sprocket
- 11 Crankshaft

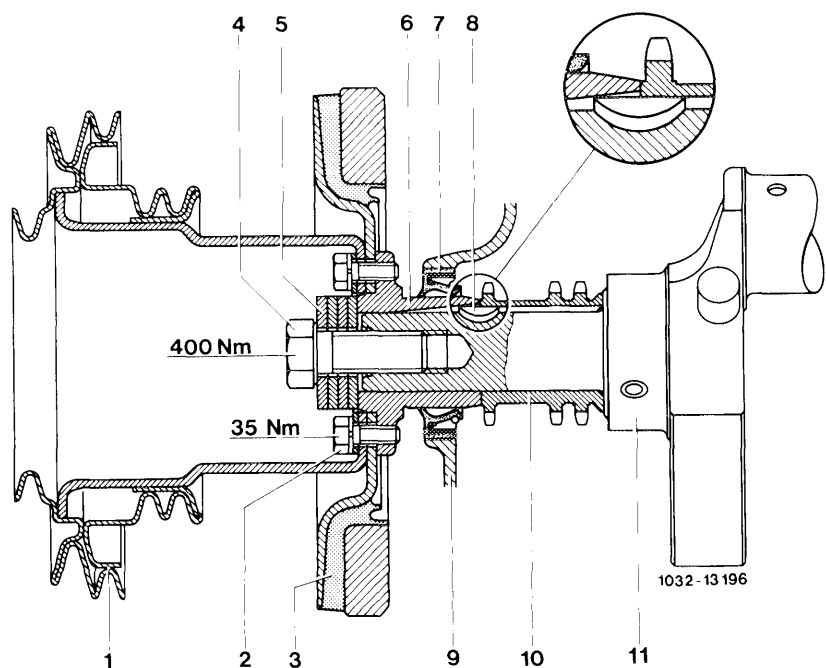

1032-13 196

8 Remove coolant pump (20–210).

9 Unscrew warming-up regulator.

10 Remove oil pump (18–210).

11 Loosen oil pan upper part (with two-piece oil pan) on crankcase, i.e. back out screws approx. 3–4 turns.

12 Drive out oil dipstick guide tube.

13 Unscrew cylinder head bolts M 8 (arrows).

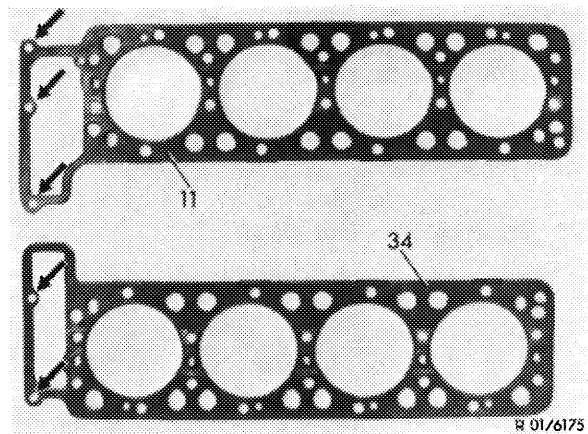

14 Disconnect TDC transmitter and remove.

15 Screw out all bolts for timing case cover.

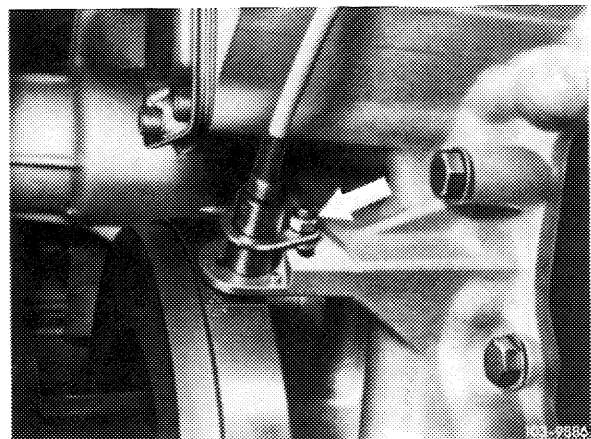

16 Force out crankshaft oil seal.

17 Take off timing case cover and remove oil pump chain from crankshaft sprocket.

Caution!

Do not damage cylinder head gaskets.

Installation

18 Renew O-rings for sealing of water galleries.

Caution!

When renewing bushes, observe the position of the oil groove **below** (arrows).

19 Coat sealing surface of timing case cover with sealing compound.

20 Grease cylinder head gaskets.

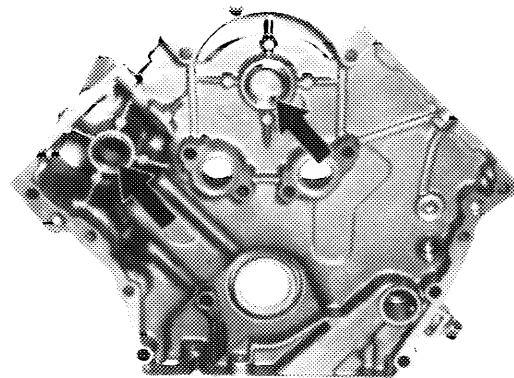

103-9559

21 When fitting the timing case cover, install the oil pump chain on the crankshaft sprocket by means of a bent piece of sheet metal.

22 First install cylinder head bolts M 8.

23 For further installation proceed vice versa to sequence of removal.