

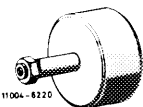



Tightening torques		Nm
Bolts for cylinder head cover		3
Crankshaft end bolt	with 3 diaphragm springs ¹⁾	270–330
	with 4 diaphragm springs ¹⁾	370–400
Mounting bolt for camshaft sprocket		100

¹⁾ See Note 03–324.

Special tools

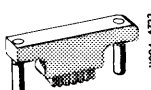
Impact puller for bearing pin (basic unit)		116 589 20 33 00
Threaded bolt M 6 x 50		116 589 01 34 00
Detent (starter motor flange left or right)		116 589 01 40 00
Torque wrench 3/4" drive, 150–800 Nm		001 589 74 21 00
Socket insert 27 mm, 1/2" drive		001 589 65 09 00

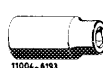
Conventional tool

Adapter 3/4" inside to 1/2" outside square drive	e.g. Hazet, D–5630 Remscheid Order No. 1058 R1
---	---

Note

All slide rails in cylinder heads of engines 116 are identical.

Likewise, the slide rails in cylinder heads of all engines 117 are identical.

On the other hand, the length of the pertinent bearing pins of light alloy engines differ from those of cast-iron engines.

Slide rails in cylinder head left inside and outside

- 1 Set piston of 1st cylinder to ignition TDC.
- 2 Remove distributor (07.5—510).

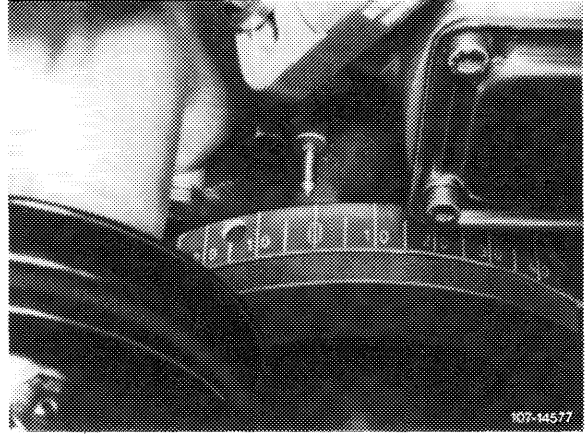

- 3 Remove power steering pump together with mounting bracket.
- 4 Knock out bearing pin with impact puller and remove slide rail.

- 5 When installing, pay attention to position of slide rail.

The bearing pins are different from those of cast-iron engines.

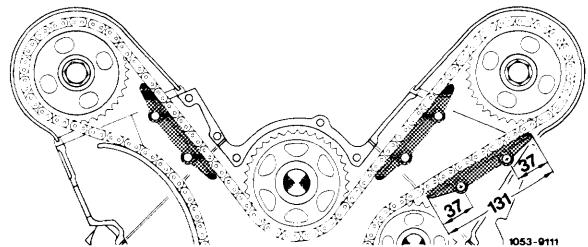

Slide rail layout engine 116

Bearing pin
Light alloy engines L = 46 mm
Cast-iron engines L = 56 mm

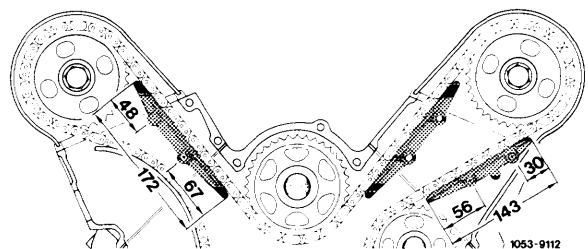

Slide rail layout engine 117

Bearing pin
Light alloy engines L = 46 mm
Cast-iron engines L = 56 mm



Slide rail in cylinder head right

- 1 Remove alternator together with mounting bracket.

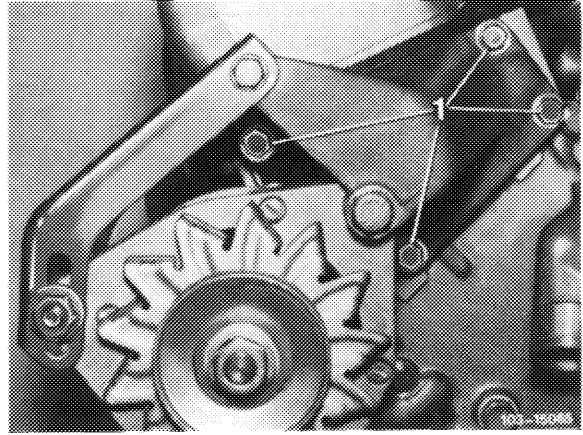

- 2 Knock out bearing pin with impact puller and remove slide rail.

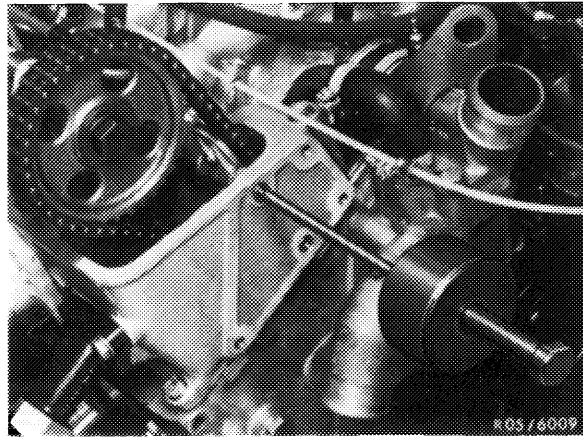

Slide rails in crankcase

- 1 Remove timing case cover (01–210).
- 2 Unscrew slide rail (87 or 79).

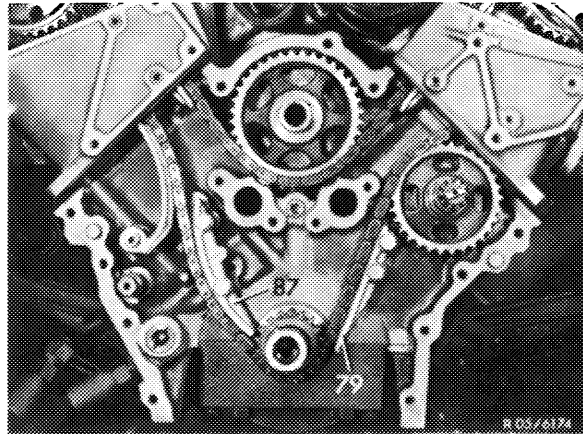

The two slide rails in the crankcase differ from those of cast-iron engines.

Engine 116.96, 117.96

- 1 Slide rail
 - 2 Bolt M 8 x 40
- a 43.8 mm

Cast-iron engine 116.98, 117.98

- 3 Slide rail
 - 4 Bolt M 8 x 38
- b 55 mm

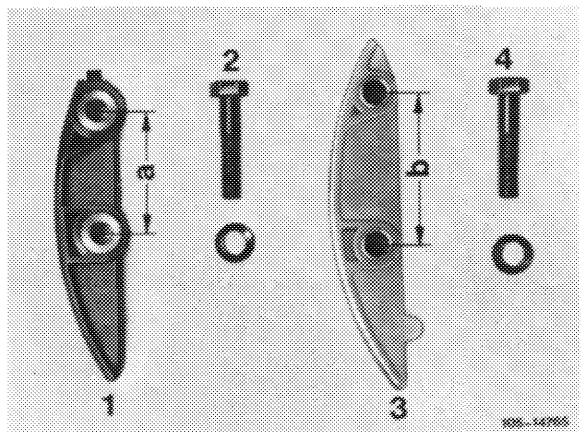

The straight slide rail (1) in the crankcase is asymmetrical (arrow) and slides onto the pins (2) screwed into the crankcase.

- 1, 2 Engine 116.96 and 117.96
- 3, 4 Cast-iron engine 116.98 and 117.98
- a 114 mm
- b 26 mm

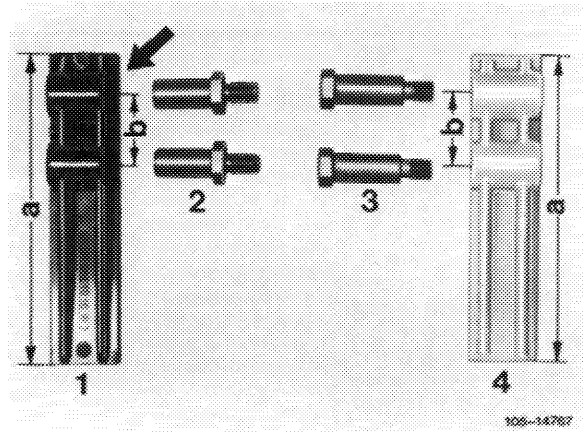

Tension arm for oil pump chain

- 1 Remove timing case cover (01-210).
- 2 Remove lock and remove tension arm (84).

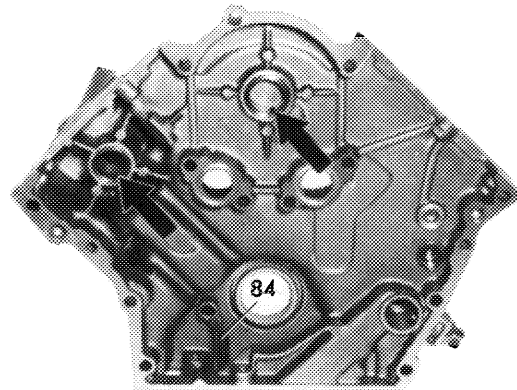

103-9559/1