

07.3-110 Testing, adjusting engine

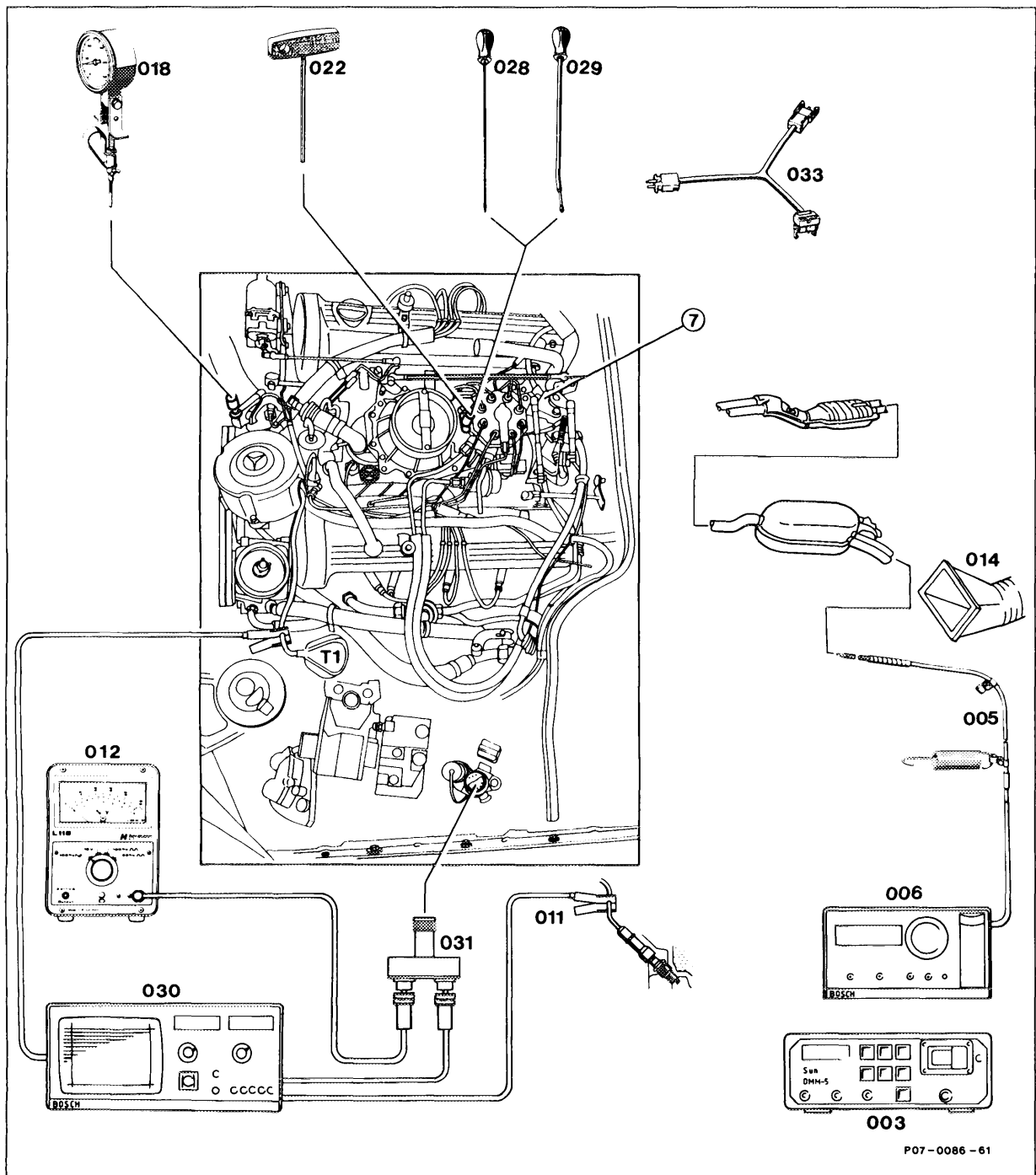

Test sheet	complete.
A C or automatic climate control	switch off.
Selector lever	move into position "P".
Testers	connect: Telethermometer (018) 124 589 07 21 00, Lambda control tester (012), Twin outlet (031), Trigger clamp (011), Exhaust sensor (005) 126 589 11 63 00, CO analyzer (006), Engine tester with oscilloscope (030), Multimeter (003), Test cable (033) 102 589 04 63 00.
Extraction device (014)	position at exhaust tail pipe.
Coolant level	check, adjust to correct level.
Engine oil level	check, pay attention to condition of oil (visual inspection).
Air filter	remove, install.
Accelerator control linkage (7)	check throttle valve for ease of movement and condition. Grease bearing points, relay levers, ball sockets.
Variable-fulcrum lever	check, adjust.
Idle stop	check.
Full throttle stop	check, adjust from accelerator pedal.
Current at actuator	test with ignition switched on.
Ignition timing	test, adjust (refer to table).
Vacuum adjustment	check (refer to table).
Oil level in automatic transmission	check, adjust to correct level.
Engine oil temperature	approx. 80 °C.
Oscilloscope image	analyze.
Intake system	test for leaks by spraying.
Operation of electrical components	check.
EGR valve	check.
Idle speed	check (refer to table).

Idle emissions level or lambda control test, adjust (refer to table).
 For resetting, use special tools,
 screwdriver (022) 000 589 14 11 00,
 extractor (028) 123 589 05 33 00,
 fitting mandrel (029) 123 589 00 15 00.

Engine running check by switching on all ancillaries.

Test and Adjustment Data

Engine	Model Year	Idle speed in rpm	Control range mA	Lambda Control
116.965	1986 →	650 ⁺ ₋ $\frac{100}{50}$	700 – 1000 mA	1) 2)
117.967	1986 →	650 ⁺ ₋ $\frac{100}{50}$	700 – 1000 mA	1) 2)
117.968	1986 →	650 ⁺ ₋ $\frac{100}{50}$	700 – 1000 mA	1) 2)

1) **1986/87**

Test lambda control at 2500 rpm and take average reading; detach purge line at electric switchover valve for this test and seal. Compare this reading with idle speed level. The average at idle speed must be greater than 5, but not more than 15, than the level measured at 2500 rpm.

2) **starting 1988**

Test lambda control at 2500 rpm and take average reading; detach purge line at electric switchover valve for this test and seal. Compare this reading with idle speed level. The average at idle speed must not vary by more than ±10 from the reading measured at 2500 rpm.

Ignition timing

Engine	Model Year	Electronic Ignition Control Unit Part No.	Engine speed in rpm	Reference resistor	Ignition timing in °CA before TDC	
					w/o vacuum	with vacuum
116.965	1986-91	003 545 91 32	3500	750 Ω	28 – 32	41 – 45
		003 545 92 32	Idle		3 – 7	10 – 14
117.967 117.968	1986-91	004 545 53 32	3500	750 Ω	24 – 28	40 – 44
		004 545 55 32	Idle		3 – 7	10 – 14

Version	Current at actuator mA
USA	75

Special tools

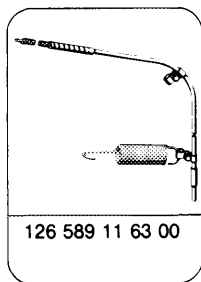
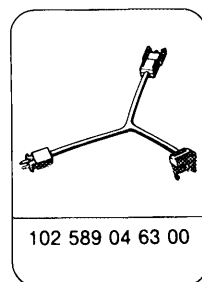
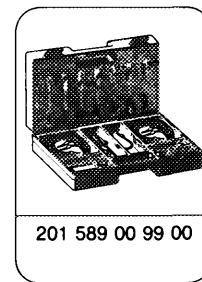
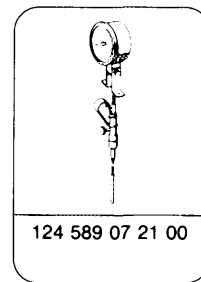
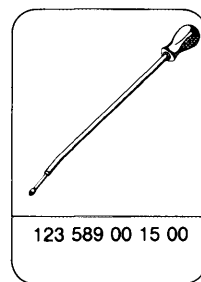
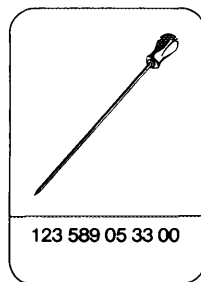
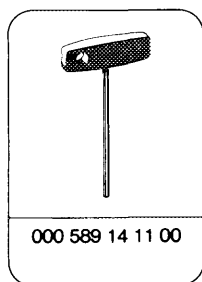

Commercial testers

CO analyzer

Engine tester (engine speed, dwell angle, ignition angle, oscilloscope, voltmeter)

e. g. Bosch, MOT 002.02
Sun, 1019

Lambda control tester

e. g. Hermann, L 115

Multimeter

e. g. Sun, DMM-5

Twin outlet

e. g. Hermann, ECD 53

Shop-made tool

Intake pipe DIN 19534 ND 125 for air flow sensor seal

Length approx. 500 mm
e. g. from air filter

Note

Test and adjust lambda control with a lambda control tester.

The lambda control or the idle emissions level must not be tested and set when the engine is hot, e. g. immediately after driving sharply or after measuring engine output on the dynamometer.

Testing, adjusting

- 1 Complete test sheet.
- 2 Switch off air conditioning system or automatic climate control. Move selector lever into position "P".
- 3 Connect testers:
 - Telethermometer (018) 124 589 07 21 00
 - Lambda control tester (012)
 - Twin outlet (031)
 - Trigger clamp (011)
 - Exhaust probe (005) 126 589 11 63 00
 - CO analyzer (006)
 - Engine tester with oscilloscope (030)
 - Multimeter (003)
 - Test cable (033) 102 589 04 63 00.

4 Position extraction device (014) at exhaust tail pipe.

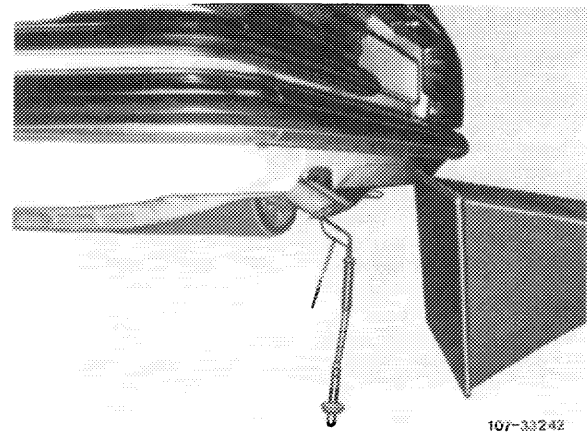

5 Check coolant level, adjust to correct level.

6 Check engine oil level, paying attention to condition of oil (visual inspection).

7 Remove air filter.

8 Check accelerator control linkage and throttle valve for condition and ease of movement. Grease all bearing points and ball sockets.

9 Engines without ASR:
Check variable-fulcrum lever, adjust. Check whether the roller (15) in the variable-fulcrum lever (13) is resting free of tension against the end stop. Adjust variable-fulcrum lever (13) with the connecting rod (1), if necessary, so that the roller (15) is resting free of tension against the end stop.

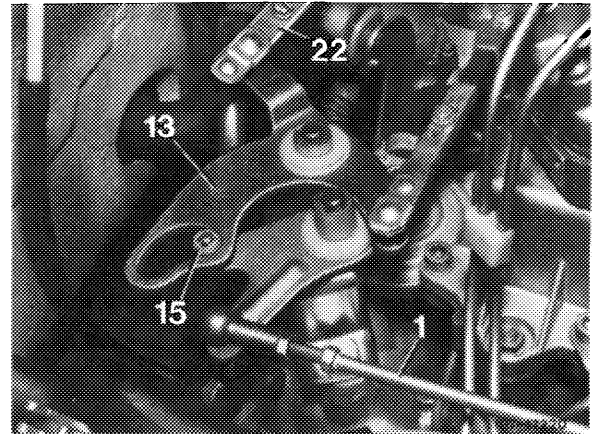

Engines with ASR:

Switch on ignition.

Relay lever potentiometer (12) must be resting against idle stop. Accelerator control lever (16) must be resting on the outer curved track of the variable-fulcrum lever (13). Adjust accelerator control (30-300).

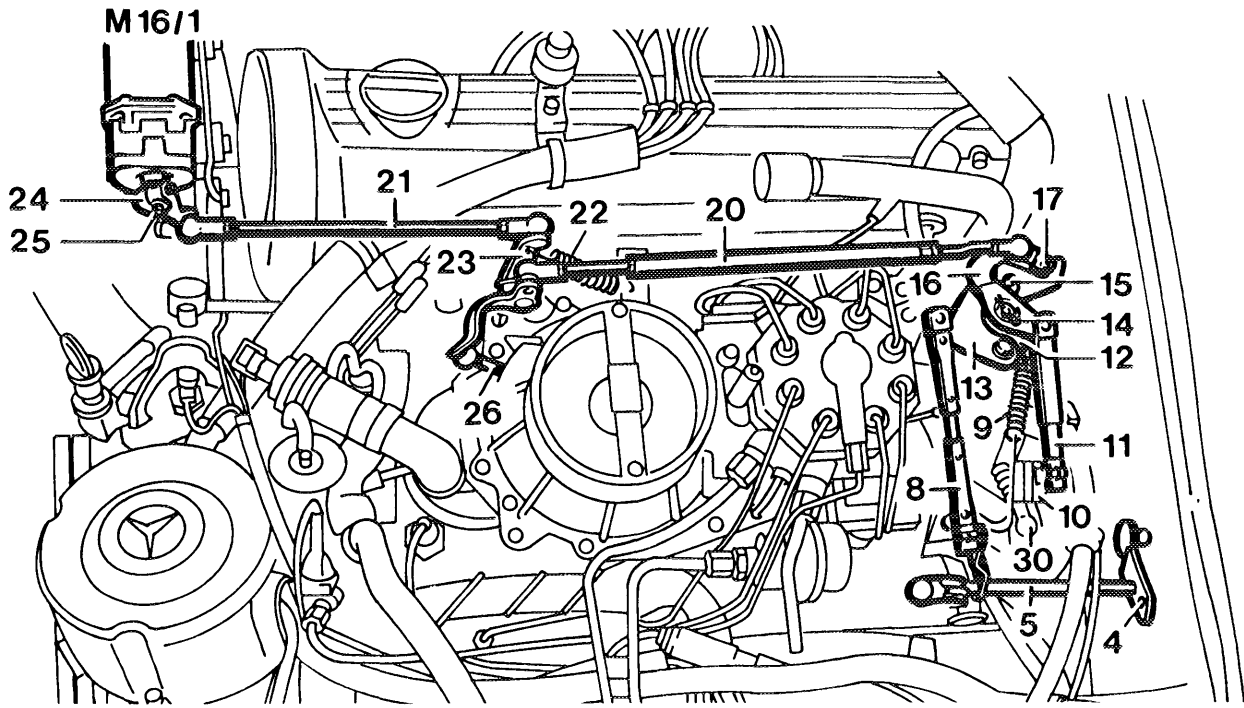

1073 - 15 374

10 Idle stop.

Check whether the throttle valve is resting against idle stop by detaching connecting rod (21) (arrow). Adjust accelerator control (30-300).

Engines with cruise control only, without ASR: Check whether the actuator is resting against idle stop of cruise control by pressing lever of actuator clockwise onto idle stop at cruise control. When attaching the connecting rod (21), ensure that the lever of the actuator is raised by approx. 1 mm off the idle stop at the cruise control. Adjust tie rod, if necessary. Adjust accelerator control (30-300).

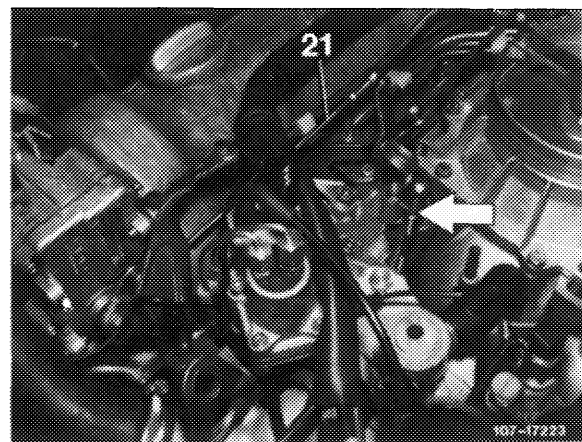

107-17223

11 Full throttle stop

Engines without ASR:

Check full throttle stop from accelerator pedal, adjust (30- 300).

Engines with ASR:

Switch on ignition. Deflect variable-fulcrum lever (13) fully and hold in this position. Check at throttle valve assy. whether throttle valve is resting against full throttle stop without linkage being over-tensioned. Adjust accelerator control (30-305).

12 Test voltages (battery and ignition coil):

No-load voltage

Connect voltmeter, paying attention to polarity at battery, and take voltage reading.

Specification: 12.2 Volts

Ignition coil

Engine not running, switch on ignition. Test voltage of terminal 15 to ground at contact 5 of diagnostic socket.

Specification: battery voltage

Test voltage difference between terminal 15 and terminal 1 at contacts 5 and 4 of diagnostic socket.

Specification: 0 Volts

If the specified voltages are not reached, test ignition system (15-540 or 15-541).

13 Test current at actuator with ignition switched on by detaching connector at actuator and connecting test cable 102 589 004 63 00 into circuit. Connect multimeter and set to mA.

Version	Current at actuator mA
USA	75

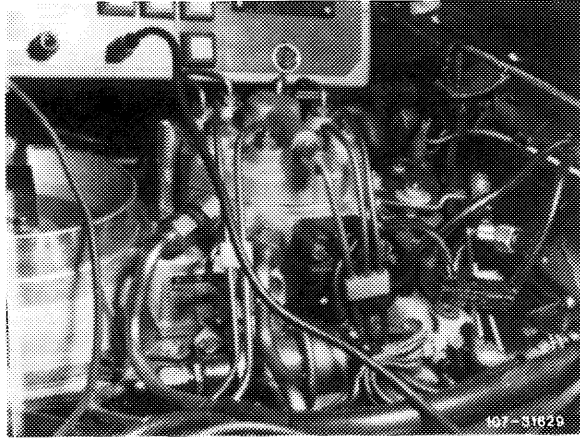

If the specified amperages are not reached, perform test routine (07.3-121).

14 Test ignition timing and vacuum adjustment (refer to table). If the specified levels are not reached, test ignition system (15-540 or 15-541).

15 Check oil level in automatic transmission.

16 Run engine until oil temperature approx. 80 °C.

17 Analyze oscilloscope image (15-525).

18 Check intake system for signs of leaks. Before spraying, fit shop-made intake pipe to air flow sensor. Spray all sealing points with iso-octane DIN 51 756 or cleaning petroleum. CO increase < 2 %.



Do not use commercial fuel for spraying (harmful vapors). Pay attention to risk of fire and do not spray onto red hot parts or parts of the ignition system.

19 Operational check of electrical components.

To determine the CIS-E control unit, switch on ignition and measure on/off ratio.

On/off ratio	Version
100 %	Control unit without fault diagnosis by measuring on/off ratio ¹⁾
70 %	CIS-E control unit with fault diagnosis by measuring on/off ratio ²⁾
85 %	(USA) California eff. 1988 CIS-E control unit with fault memory for on-board diagnosis system

¹⁾ Certain cars only at start of series production through to production date 551 in CIS-E control unit.

²⁾ Starting date of production 552 the microprocessor for fault detection is integrated in the CIS-E control unit.

Engines with fault diagnosis by measuring on/off ratio

Operational check of idle and full load contact.

Specifications:

Idle contact:

Switch on ignition,

on/off ratio readout 70 %.

Deflect air flow sensor plate,

on/off ratio readout 10 %, if readout 70 % test throttle valve switch (07.3-121).

Full load contact:

Switch on ignition,

on/off ratio readout 70 %.

Open throttle valve fully,

on/off ratio readout 20 %, if readout 40 % test air flow sensor potentiometer (07.3-121).

Engines without fault diagnosis by measuring on/off ratio

Start engine when at normal operating temperature. Engine running at idle speed. If readout does not fluctuate, perform test routine (07.3-121).

20 Check operation of exhaust gas recirculation valve. Detach vacuum line (arrow) at EGR valve (60), connect tester to EGR valve and pressurize with vacuum. If engine running does not significantly deteriorate, renew EGR valve. Check control mechanism, if necessary (14-475).

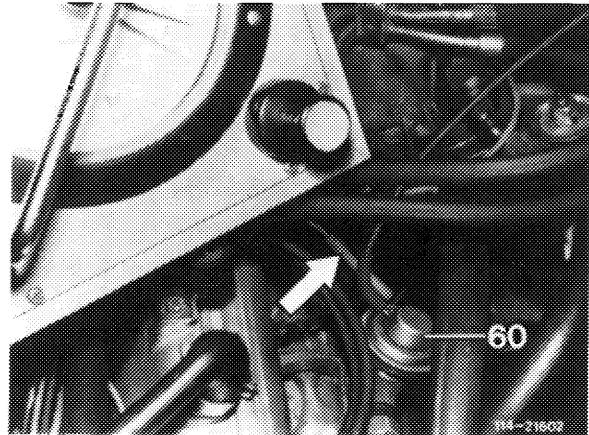

21 Install air filter.

22 Test idle speed (refer to table).

Note

If engine fitted with electronic idle speed control, idle speed cannot be adjusted. If idle speed varies from specification, test electronic idle speed control (07.3-112).

23 Test idle emissions level (refer to table). This is measured at exhaust tail pipe. Set idle emissions level (refer to step 24).

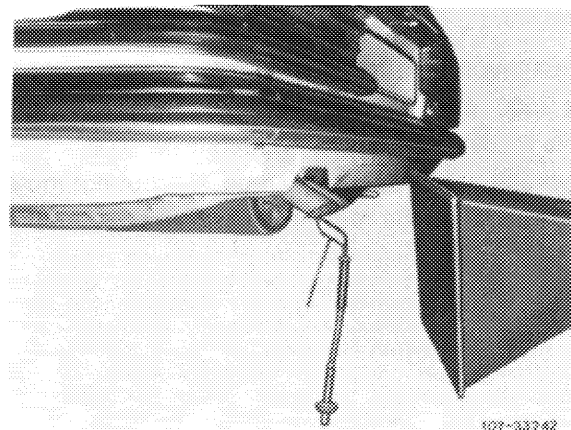

24 Test lambda control (refer to table). Detach purge line to throttle valve assy. at purge valve (78) and seal. Press test signal selector of Hermann lambda control tester to position 100 % \odot , or press 100 % IR button on Bosch tester.

Set lambda control (refer to step 24).

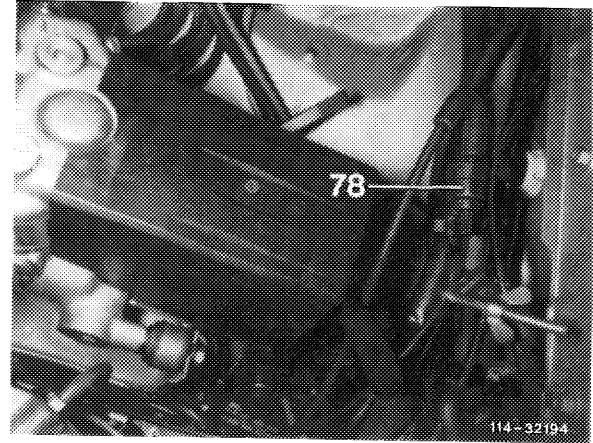

Note

The readout must fluctuate during the measurement. If a constant readout is indicated, there is a fault in the lambda control, e. g. O₂ sensor disconnected.

Refer to "Testing electrical components of CIS-E injection system" (07.3-121) for troubleshooting table.

Test on/off ratio of 1988-91 cars at 2500 rpm and take average reading. Compare this reading with the idle speed level. The average at idle speed must not vary by more than ± 10 from the reading measured at 2500 rpm.

Test on/off ratio of 1986/87 cars at 2500 rpm and take average reading. Compare this reading with the idle speed level. The average at idle speed must be >5 , but not more than 15, than the reading measured at 2500 rpm.

25 Set idle emissions level and lambda control (refer to table).

Withdraw security plug (4) with the extractor.

Press the screwdriver (1) through the recess on the top section of air filter onto the adjusting device (2). Press the adjusting device down with the screwdriver against to the spring force, turn it slightly until the hex head (3) engages in the mixture adjusting screw (61).

Turn to the left for leaner mixture – on/off ratio increases

Turn to the right for richer mixture – on/off ratio drops

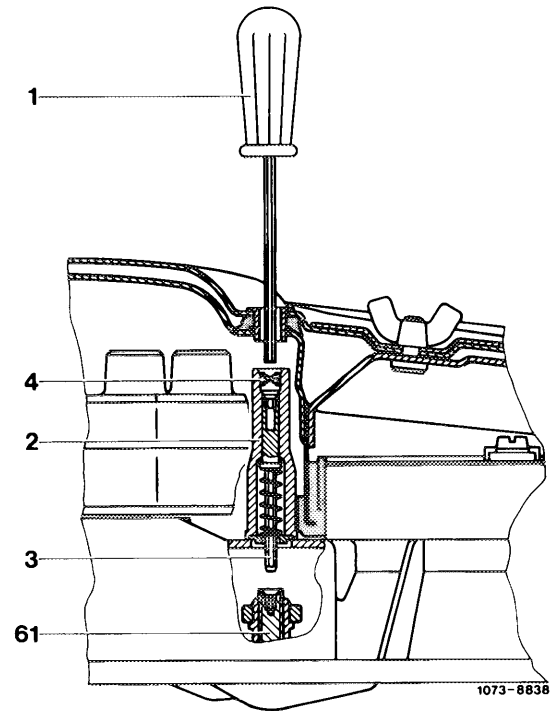

- 1 Screwdriver
- 2 Adjusting device
- 3 Hex head
- 4 Security plug
- 61 Mixture adjusting screw

After each adjustment, depress accelerator pedal briefly; reset, if necessary.

After adjusting, insert a blue security plug (4), Part No. 000 997 59 86, with the fitting mandrel.

Reconnect purge line (only if lambda control fitted).

26 Test engine running by moving selector lever into Drive position, switching on air conditioning system/automatic climate control, and turning power steering to full lock. Engine must run smoothly.