

14-475 Checking exhaust gas recirculation (EGR)

A. Exhaust gas recirculation with vacuum control valve model year 1986/87

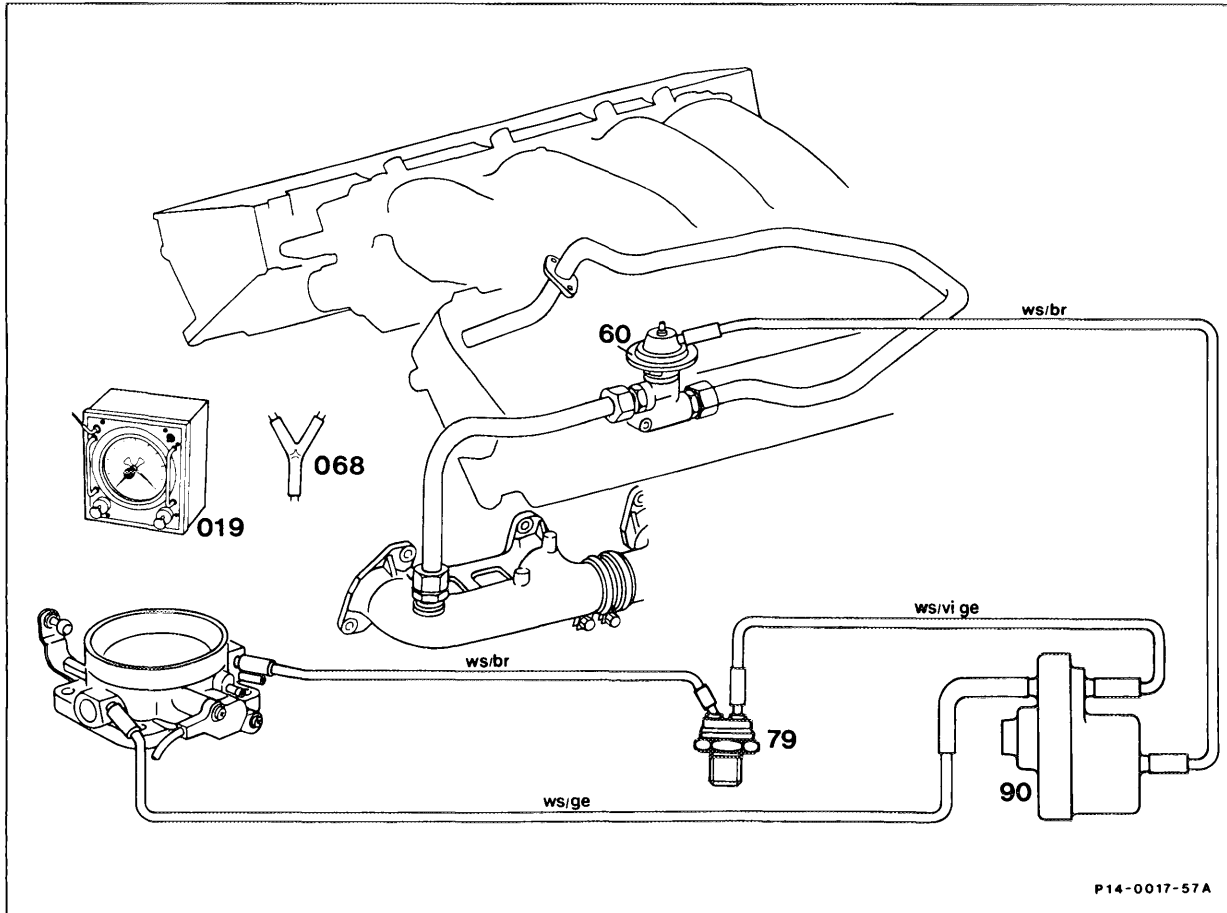

Impulse period display	Test step/ Scope of test	Measuring device/ Test connection	Actuation/ Requirement	Set value/ Function	Possible cause/Remedy
-	1 Vacuum line ws/br	on EGR valve (60)	pull off	-	-
-	2 Vacuum tester (019)	on EGR valve (60)	connect, apply 300 mbar vacuum.	switches audibly	Renew EGR valve
-	3 Engine at idle speed	on EGR valve (60)	connect, apply 300 mbar vacuum.	Irregular engine operation	Renew EGR valve
-	4 Check function of thermovalve (79)	Pull off both vacuum lines. Connect vacuum tester to inclined connection.	Connect vacuum.	Coolant temperature > 50 °C open. < 50 °C closed.	Renew thermovalve.
-	5 Check thermovalve (79) for leaks	Connect vacuum tester to inclined connection.	Plug straight connection. Apply vacuum.	Coolant temperature > 50 °C vacuum remains.	Renew thermovalve.
-	6 Check vacuum control valve (90)	Connect vacuum tester with Y-hose (1) part No. 117 078 01 45 to EGR valve	Start engine at operating temperature. Slowly increase speed.	approx. 1500 rpm < 100 mbar approx. 3200 rpm > 400 mbar	If > 400 mbar are measured at 1500 rpm, check line assignment on throttle assembly (see Fig.). If set values are not obtained, renew vacuum control valve.

1	Mixture control unit	A1e10	O ₂ -sensor indicator lamp
40	Diaphragm pressure controller	A1p8	Electronic speedometer
55	Fuel filter	B2	Air flow sensor position indicator
57	Fuel reservoir	B11/2	Coolant temperature sensor (EZL/CIS-E)
74	Fuel cooler	B18	Altitude correction capsule
75	Fuel tank	G3/2	Heated O ₂ -sensor
76	Vent valve	L5	Crankshaft position sensor
77	Charcoal canister	M3	Fuel pump
78	Purge valve	N1/2	Electronic ignition control unit (EZL)
79	50 °C thermostatic valve	N3	CIS-E control unit
89	Exhaust gas recirculation valve	N8	Idle speed control unit
90	Control valve	N16/4	Fuel pump relay with kickdown cut-out
92	Injection valve	R17/1	Reference resistor (CIS-E)
125	Air pump	S29/2	Full load/idle speed detection throttle valve switch
126	Air shutoff valve	T1	Ignition coil
127	Check valve (injected air)	Y1	Electrohydraulic actuator
157	Firewall catalytic converter	Y5/1	A/C compressor electromagnetic coupling
158	Underfloor catalytic converter	Y6	Idle speed air valve
		Y8	Starting valve
		Y32	Air pump switchover valve
		Y33	Air pump electromagnetic coupling

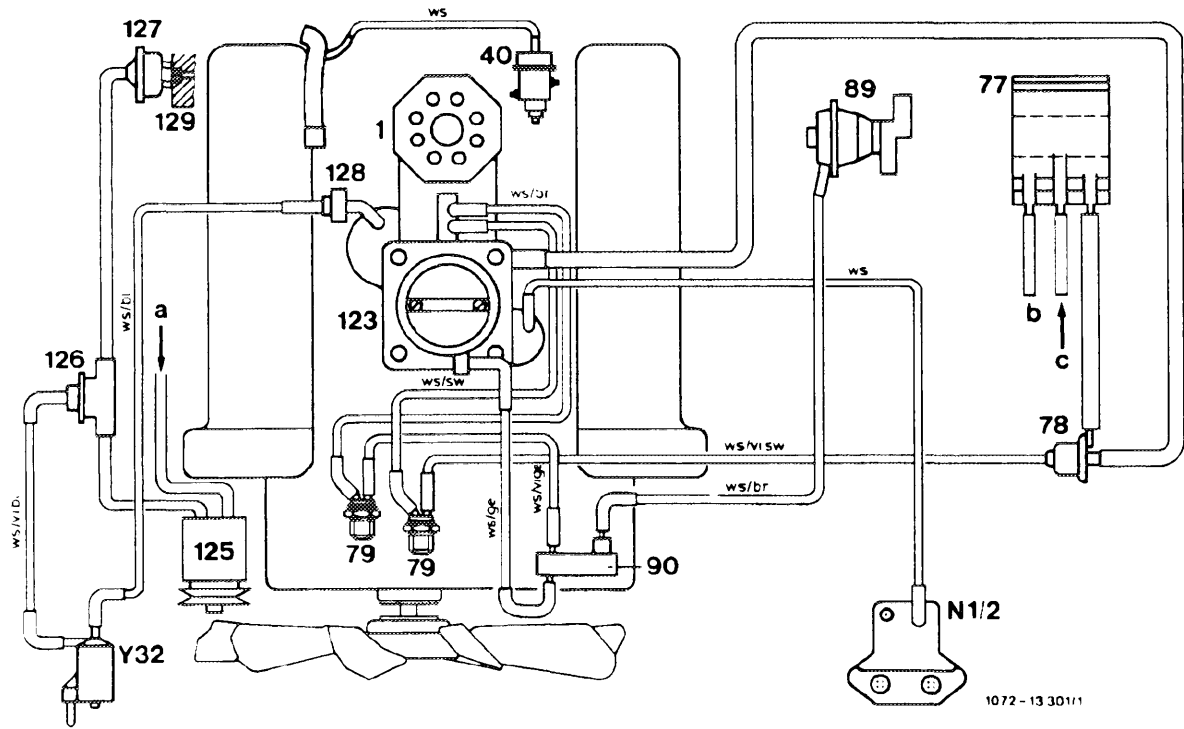

Function diagram air injection and exhaust gas recirculation up to 08/87

N1/2	Control unit ignition system (EZL)	79	Therموالve
Y32	Change-over valve air pump	89	Exhaust gas recirculating valve
a	from air cleaner	90	Control valve
b	to fuel tank	123	Throttle assembly
c	Ventilation	125	Air pump
1	Mixture control unit	126	Air shut-off valve
40	Diaphragm pressure regulator	127	Check valve (injection air)
77	Charcoal canister	128	Check valve (vacuum)
78	Purge valve	129	Timing case cover

B. Exhaust gas recirculation without vacuum control valve as of model year 1988

Note

The control valve in the vacuum line between throttle assembly and exhaust gas recirculation valve is no longer required as of 09/87.

The exhaust gas recirculation valve is connected with vacuum directly only as a function of the thermovalve.

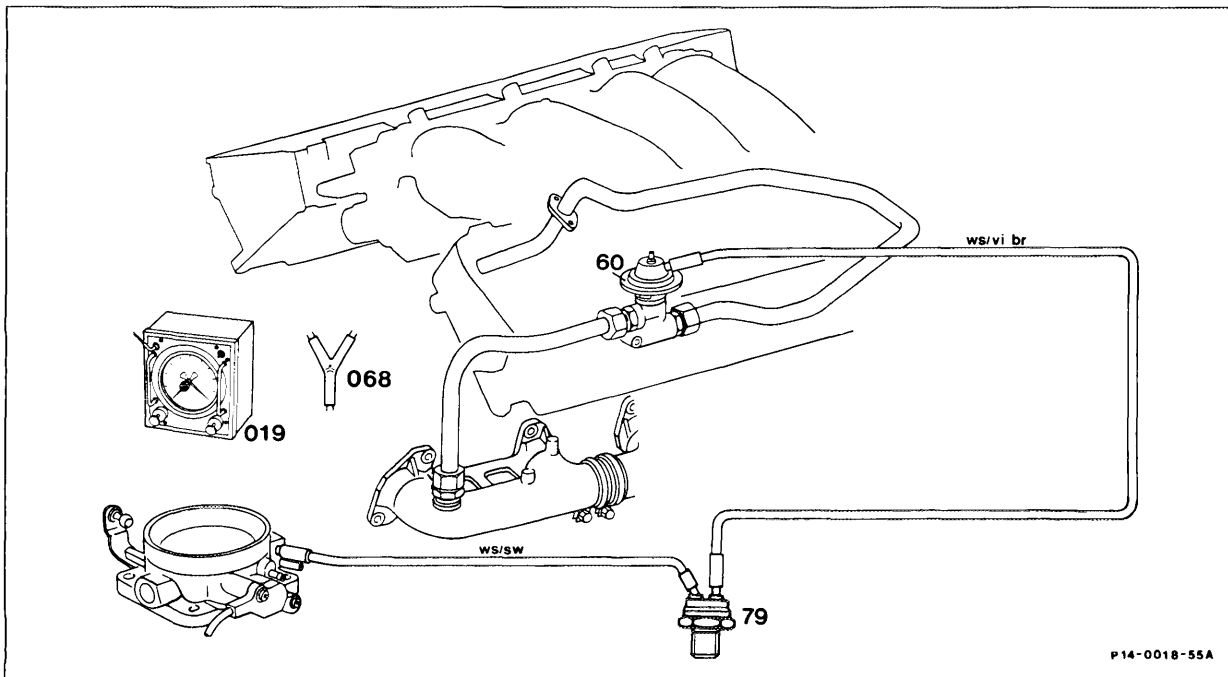

Impulse period display	Test step/ Scope of test	Measuring device/ Test connection	Actuation/ Requirement	Set value/ Function	Possible cause/Remedy
-	1 Vacuum line ws/vibr	on EGR valve (60)	pull off	-	-
-	Vacuum tester (019)	on EGR valve (60)	connect, apply 300 mbar vacuum.	switches audibly	Renew EGR valve
-	3 Engine at idle speed	on EGR valve (60)	connect, apply 300 mbar vacuum.	Irregular engine operation	Renew EGR valve
-	4 Check function of thermovalve (79)	Pull off both vacuum lines. Connect vacuum tester to inclined connection.	Connect vacuum.	Coolant temperature > 50 °C open. < 50 °C closed.	Renew thermovalve.
-	5 Check thermovalve (79) for leaks	Connect vacuum tester to inclined connection.	Plug straight connection. Apply vacuum.	Coolant temperature > 50 °C vacuum remains.	Renew thermovalve.