

A. Model 107

Oil circuit with air oil cooler next to radiator

Engines 116.960 (except regional version), 117.960.

Oil circuit without air oil cooler

Engines 116.960 (AUS) (J) (S) (USA) 116.962/964

117.962/964, 117.967 (AUS) (J) (USA)

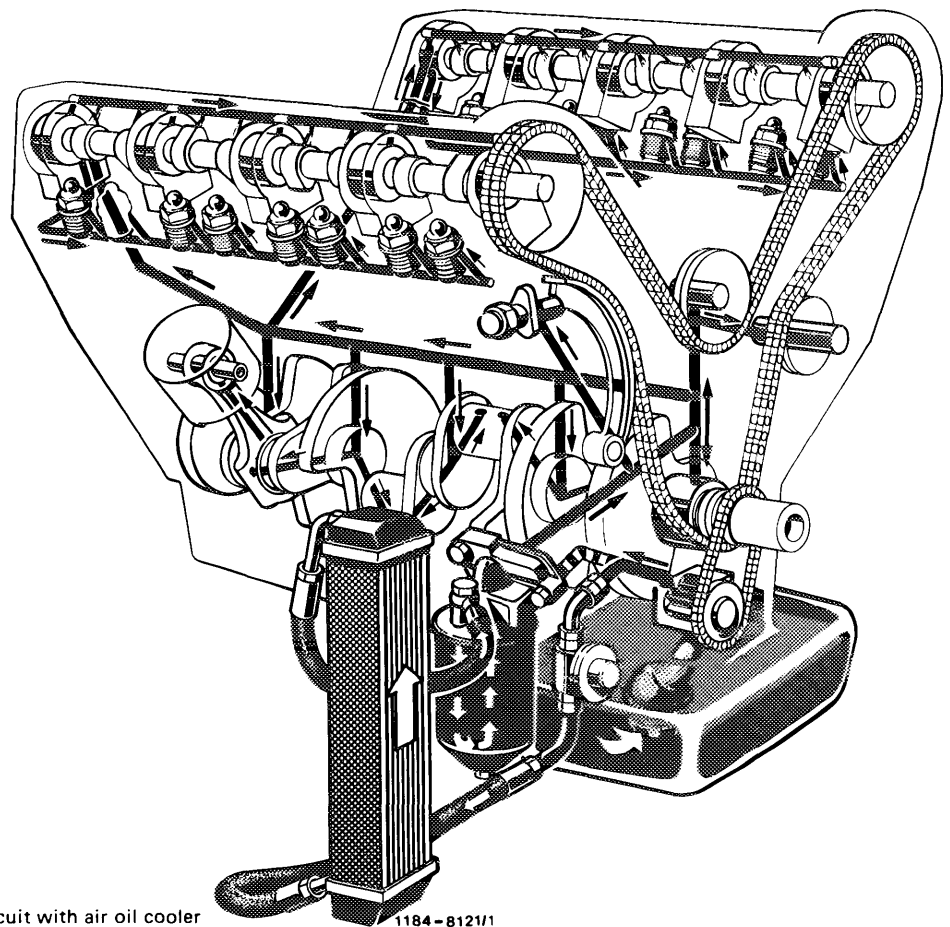

**Note**

---

The oil circuit is pressure-regulated via the air oil cooler.

B. Model 126

Oil circuit with air oil cooler next to radiator  
(version A)  
Engines 116.961, 117.961.

Oil circuit without air oil cooler  
Engines 116.961 (AUS) (J) (USA) 116.963/965,  
117.963/965/968 (AUS) (J) (USA)

Oil circuit with air oil cooler in right-hand wheelhouse  
(version B)  
Engines 117.968 and special protection vehicles.

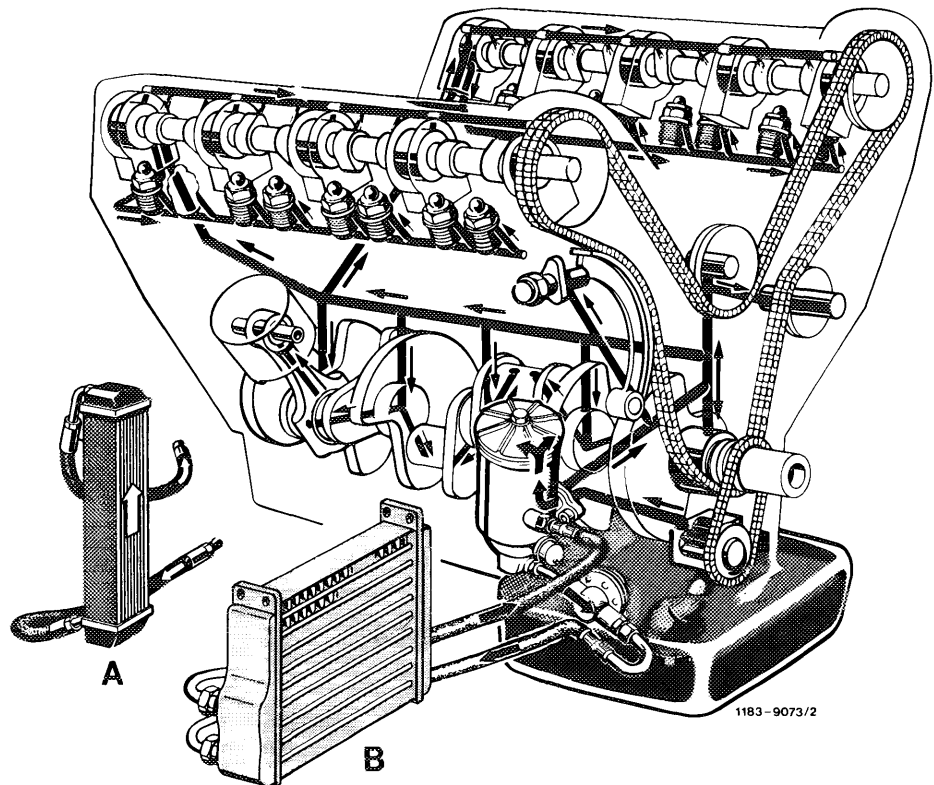

Oil circuit with air oil cooler

**Note**

---

The oil circuit via the air oil cooler is regulated by means of a thermostat and a control valve in the oil filter.