

A. Model 107

Oil filter,
engines 116.960/962 and
117.960/962/964/967

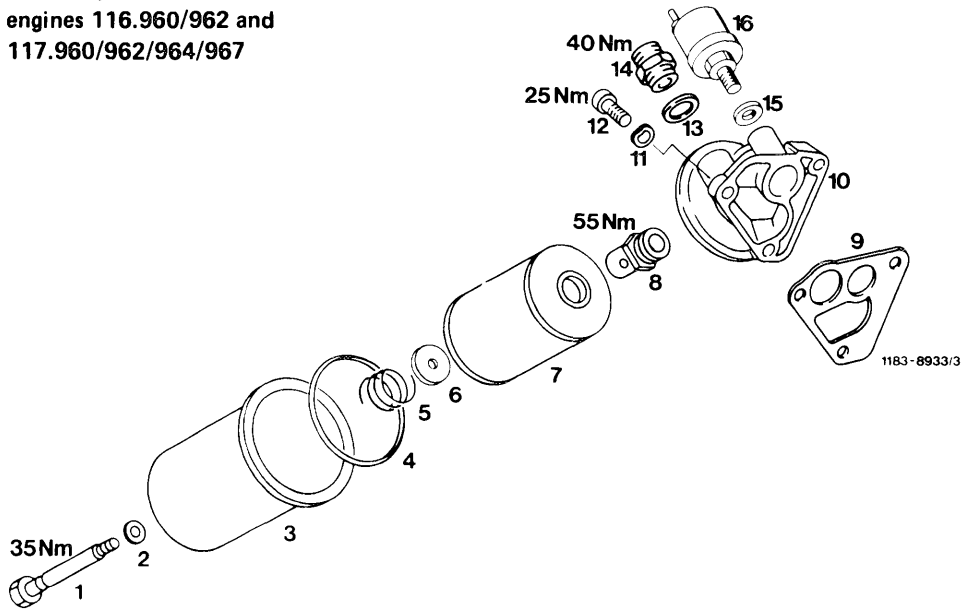

- 1 Center bolt
- 2 Sealing ring Check, renew if required
- 3 Oil filter housing
- 4 O-ring Renew
- 5 Compression spring Observe installation position
- 6 Spring retainer For oil filter element
- 7 Oil filter element Ensure use of correct oil filter element
- 8 Screw fitting
- 9 Gasket Renew
- 10 Intermediate flange
- 11 Spring washer 3 required
- 12 Internal socket head screw 3 required
- 13 Sealing ring¹⁾
- 14 Screw fitting¹⁾
- 15 Sealing ring
- 16 Electric oil pressure transmitter

¹⁾ Not required for engines without air oil cooler: 116.960 (AUS) (J) (S) (USA) as from 1981, 116.962/964 and 117.962/964/967.

Note

New oil filters are supplied with initial operation filter elements which, on new engines, should be used up to the inspection at 1000–1500 km.

These filter elements have a limited service life and must be exchanged for filter elements part No. 000 180 05 09 if new oil filters are fitted to run-in engines.

Removal (model 107)

- 1 Remove oil filter housing.
- 2 On engines 116.960 standard version and 117.960, disconnect oil cooler line from intermediate flange.
- 3 Pull single-plug connection of electric line to the oil pressure indication in the instrument cluster from the oil pressure transmitter.
- 4 Unscrew fastening screws for intermediate flange and remove intermediate flange.
- 5 Remove remains of gasket from flange surface on crankcase.

First close the openings (arrows) in such a way that no remains of gasket can enter the oil ducts in the crankcase.

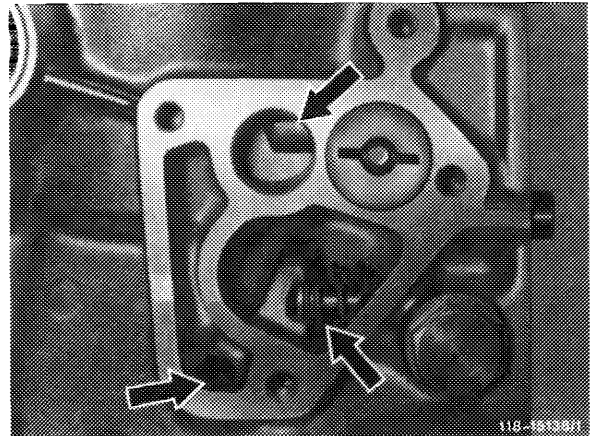

Installation

- 6 Position intermediate flange with new gasket and tighten fastening screws for intermediate flange to 25 Nm.
- 7 On engines 116.960 standard version and 117.960, connect oil cooler line to intermediate flange and tighten coupling nut to 25 Nm.
- 8 Plug single-plug connection of electric line to oil pressure indication in the instrument cluster to the oil pressure transmitter.
- 9 If required, renew sealing ring of center bolt and oil filter element. Position oil filter housing with new O-ring and tighten center bolt to 40 Nm.

Note: If compression spring with spring retainer has been removed, reinstall part in such a way that the spring retainer faces towards the oil filter element.

- 10 Run engine and check for leaks.
- 11 Check oil level, correct if necessary.

B. Model 126

Oil filter, engines 116.961, 116.963, 116.965, 117.961 and 117.963, 117.965, 117.968

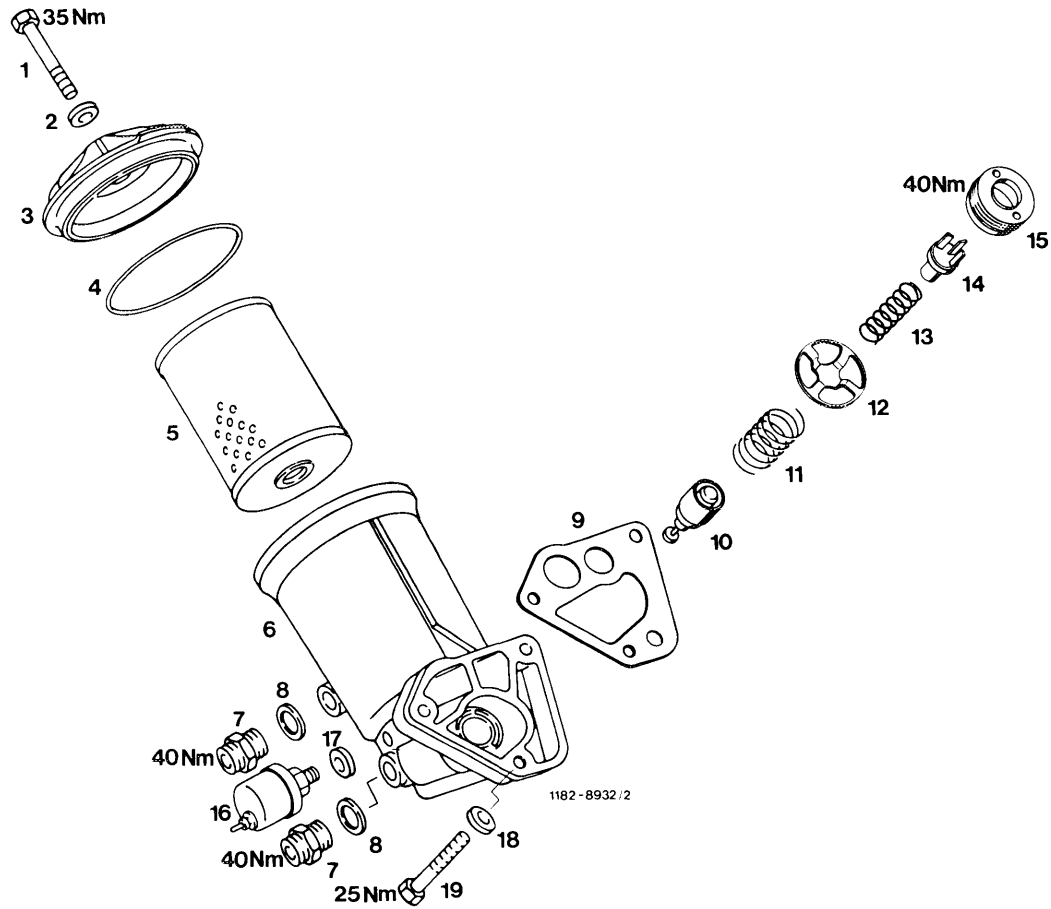

- | | | | |
|----|---|-------|---|
| 1 | Center bolt | | Tighten to 30 Nm |
| 2 | Sealing ring | | Check and replace if required |
| 3 | Oil filter cover | | |
| 4 | O-ring | | Renew |
| 5 | Oil filter element | | Ensure use of correct element |
| 6 | Oil filter housing | | Clean |
| 7 | Screw fitting ¹⁾ | | Tighten to 40 Nm |
| 8 | Sealing ring ¹⁾ | | Renew |
| 9 | Gasket | | Renew |
| 10 | Thermostat with control valve ¹⁾ | | Beginning of control 110 ± 4 °C, end of control (fully opened) 125 ± 4 °C |
| 11 | Compression spring ¹⁾ | | |
| 12 | Spring retainer ¹⁾ | | |
| 13 | Compression spring | | |
| 14 | Valve cone return flow shut-off valve | | |
| 15 | Valve seat ring return flow shut-off valve | | Tighten to 40 Nm |
| 16 | Electric oil pressure transmitter | | |
| 17 | Sealing ring | | Renew |
| 18 | Spring washer | | 3 required |
| 19 | Hex. head bolt | | 3 required, tighten to 25 Nm |

¹⁾ Not required on engines without air oil cooler except for subsequent installation of an oil cooler:
 116.961 (AUS) (J) (S) (USA) as of 1981, 116.963, 117.963/965/968

Note

New oil filters are delivered with initial operation filter elements which are used on new engines up to inspection at 1000–1500 km.

These filter elements have a limited service life and should be exchanged for filter elements part No. 000 180 06 09 if new oil filters are attached to run-in engines.

Removal (model 126)

- 1 Remove oil filter cover.
- 2 On engines 116.961 standard version and 117.961, unscrew both oil cooler lines on oil filter housing and remove pipe elbow between oil filter and damper.
- 3 Pull single-plug connection of electric line for oil pressure indication in instrument cluster from oil pressure transmitter.
- 4 Unscrew fastening screws for oil filter and remove oil filter.
- 5 Remove remains of gasket from flange surface on crankcase.

First close openings (arrows) so that no remains of gasket can enter the oil ducts in the crankcase.

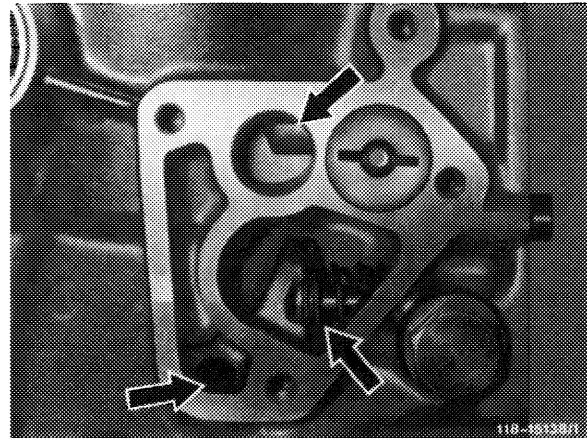

Installation

- 6 Position the oil filter with new gasket and tighten fastening screws to 25 Nm.
- 7 Plug single-plug connection of electric line for oil pressure indication in instrument cluster onto oil pressure transmitter.

8 On engines 116.961 standard version and 117.961/968 and special protection vehicles, connect oil cooler lines to oil filter housing and tighten coupling nuts to 25 Nm. Install pipe elbow between oil filter and damper.

9 If required, replace sealing ring of center bolt and oil filter element. Mount oil filter cover with new O-ring and tighten center bolt to 30 Nm.

10 Run engine and check for leaks.

11 Check oil level and correct if required.