

## 20-430 Checking expansion tank cap

### Expansion tank cap

Part No.	Code figure	Pressure relief valve opens at bar gauge pressure
124 500 01 06 Production breakpoint as of November 87	140	1.4 ± 0.1
124 501 05 15 <sup>1)</sup> Production breakpoint and spare part as of October 86	140	1.4 ± 0.1
123 501 00 15 Production breakpoint as of June 1983	120	1.2 ± 0.1
123 501 02 15 <sup>1)</sup> Spare part until Oct. 86	120	1.2 ± 0.1
123 501 01 15	100	1.0 ± 0.2
Vacuum valve opens as of		0.1 bar vacuum

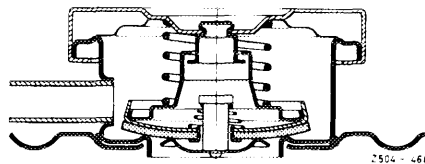

<sup>1)</sup> Required on vehicles with overflow tank.

### Special tools

Tester for cooling system and radiator cap

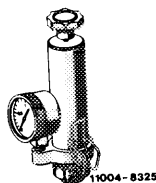

001 589 48 21 00

Double connection for expansion tank cap to tester



000 589 75 63 00

## Note

---

Since June 1983, a cap with increased opening pressure has been installed. It can also be installed in previously manufactured vehicles.

The spare part cap (B) is provided with a spring-loaded seal and an additional rubber sealing ring and provides a better seal also on older-type expansion tanks with a possibly uneven contact surface.

On vehicles with overflow tank, a cap with higher opening pressure (1.4 bar) must be installed. (1.2 bar up to October 1986, 1.4 bar as of October 1986).

The caps with higher opening pressure ensure at least 1 bar gauge pressure in the cooling system even on older vehicles. This will provide increased protection against coolant ejection.

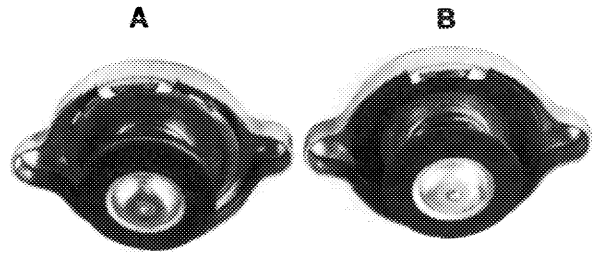

120-27353

## Checking pressure relief valve

---

- 1 Attach double connector 000 589 75 63 00 to tester 001 589 48 21 00 with the retaining clamps.
- 2 Place expansion tank cap on the double connector.
- 3 Check the opening pressure by pumping.

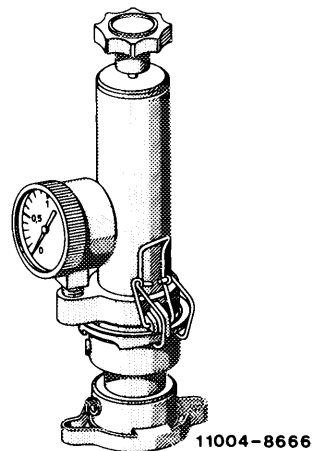

11004-8666

## Checking vacuum valve

---

The vacuum valve (arrow) should rest against the rubber seal, be easily lifted and snap back upon release.

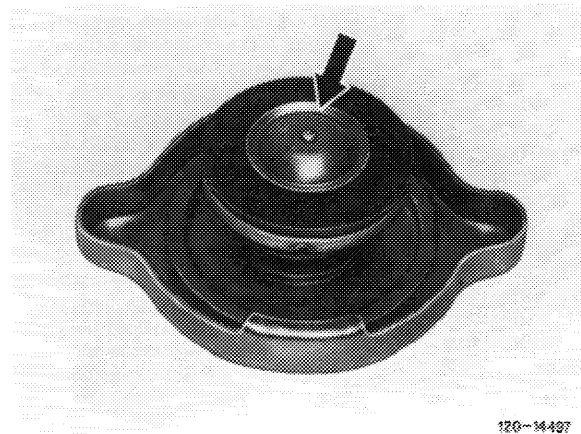

120-14437