

47-300 Checking fuel evaporation control system

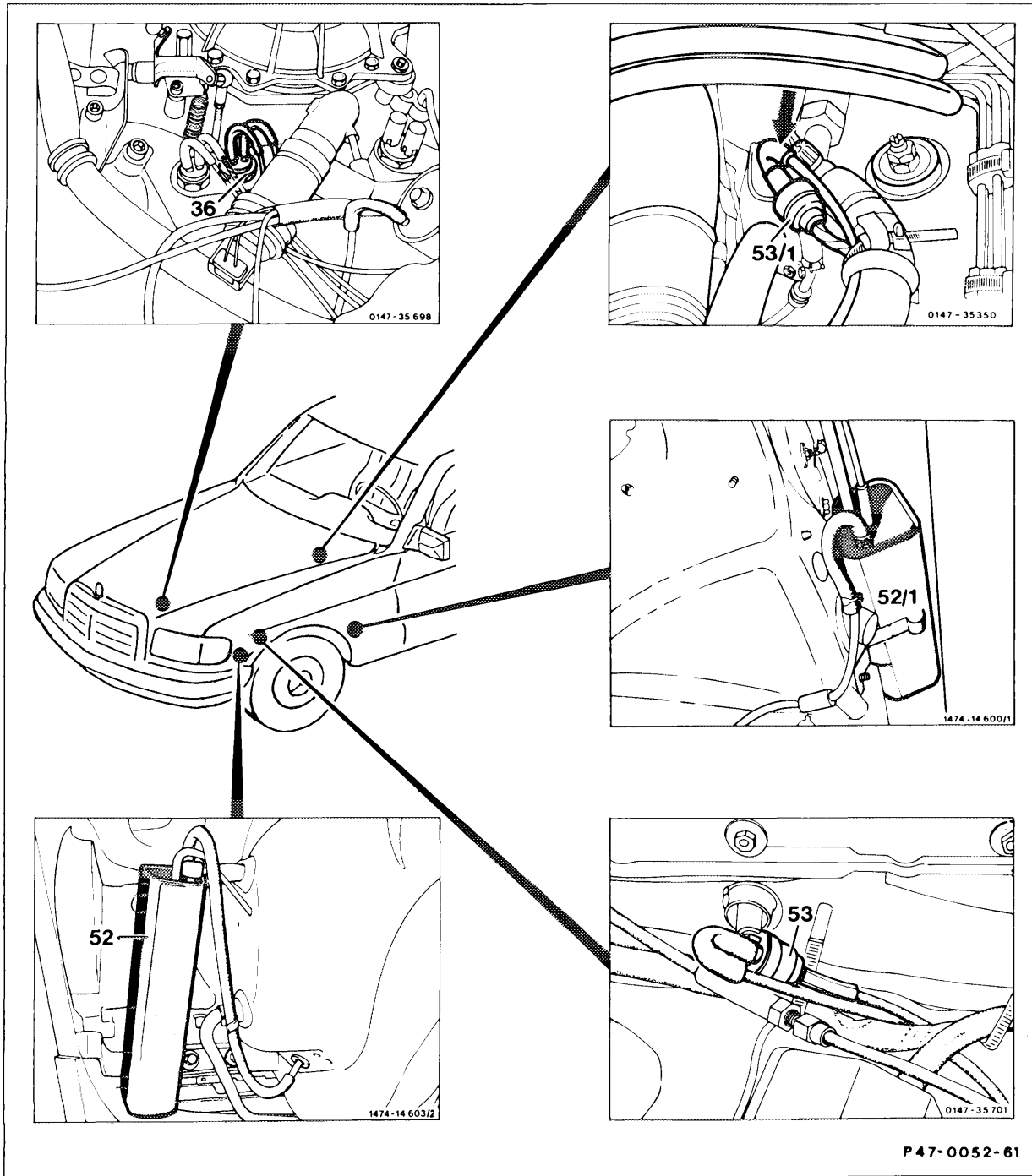

- 36 Thermovalve 50 °C red, 70 °C black/white
- 52 Charcoal canister Model 107
- 52/1 Charcoal canister Model 126

- 53 Purge valve Model 107, 126
- 53/1 not used

Thermovalve (36) check that passage is clear.
 Lines check that correctly connected, in good condition and clear (remove bulkhead in front left wheelhouse, if necessary).

Engine oil temperature approx. 80 °C.
 Purge valve (53, 53/1) detach line at right angled connection fitting in left side of engine compartment. Slowly increase engine speed to 3000 rpm. No suction action at idle speed. Suction action commences as engine speed increases.

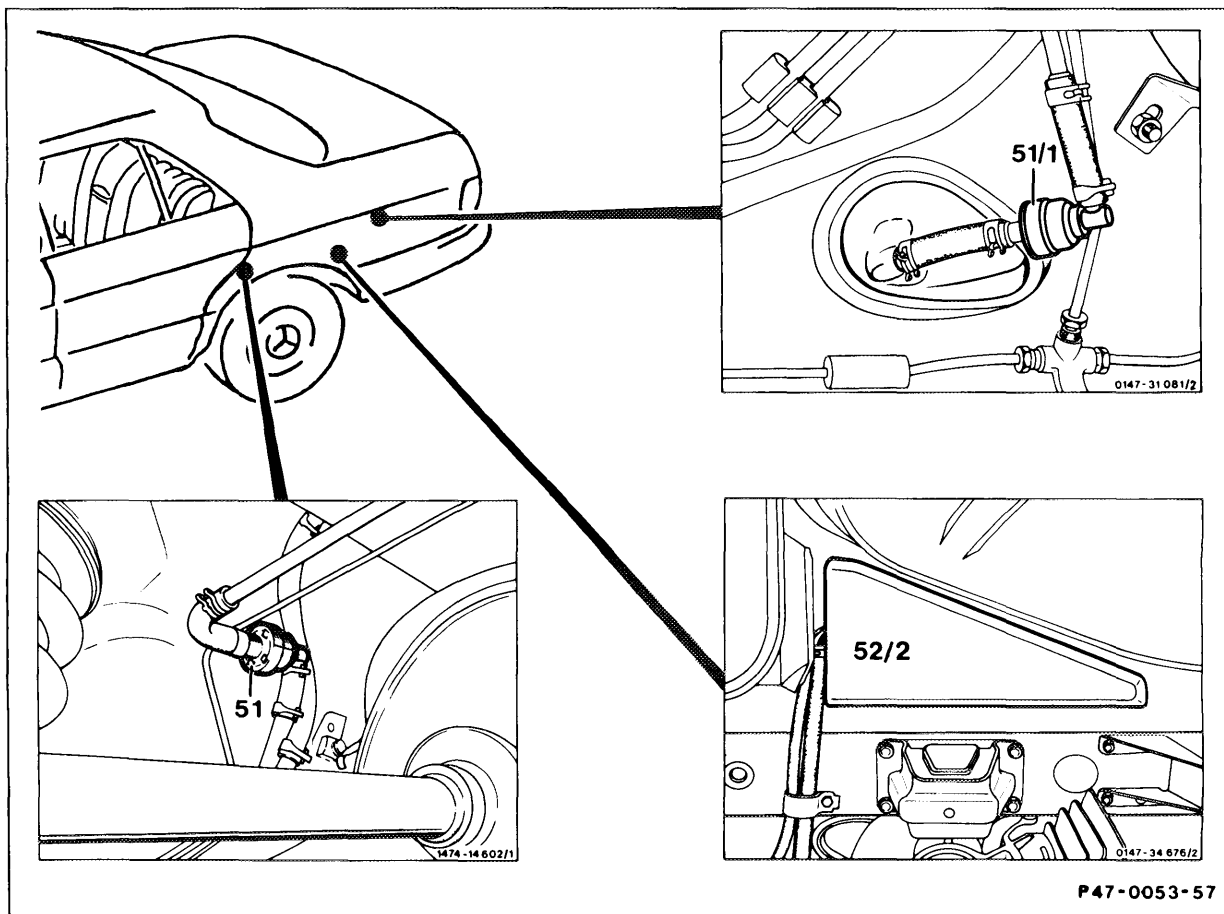

51 Vent valve Model 107
 51/1 Vent valve Model 126

52/2 not used

Vent valve (51, 51/1) check for proper operation.

Note

Connect tester 201 589 13 21 00 to connection fitting to fuel tank (pressure 30–50 mbar, vacuum 1–16 mbar).

Charcoal canister (52, 52/1, 52/2)

check. The passages between the connections must be clear.

Tester 201 589 13 21 00.

Start engine and slowly accelerate to approx. 3000 rpm. No vacuum must be indicated on tester. If necessary, renew charcoal canister.

Special tools

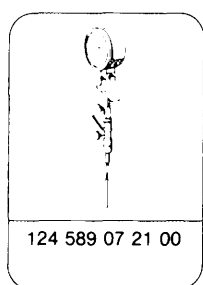
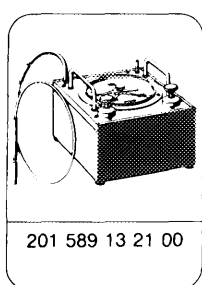

Note

Model 126

The casing of the charcoal canister has been manufactured of plastic since 09/87 (previously sheet metal).

When replacing part, always replace like with like.