

Model 116

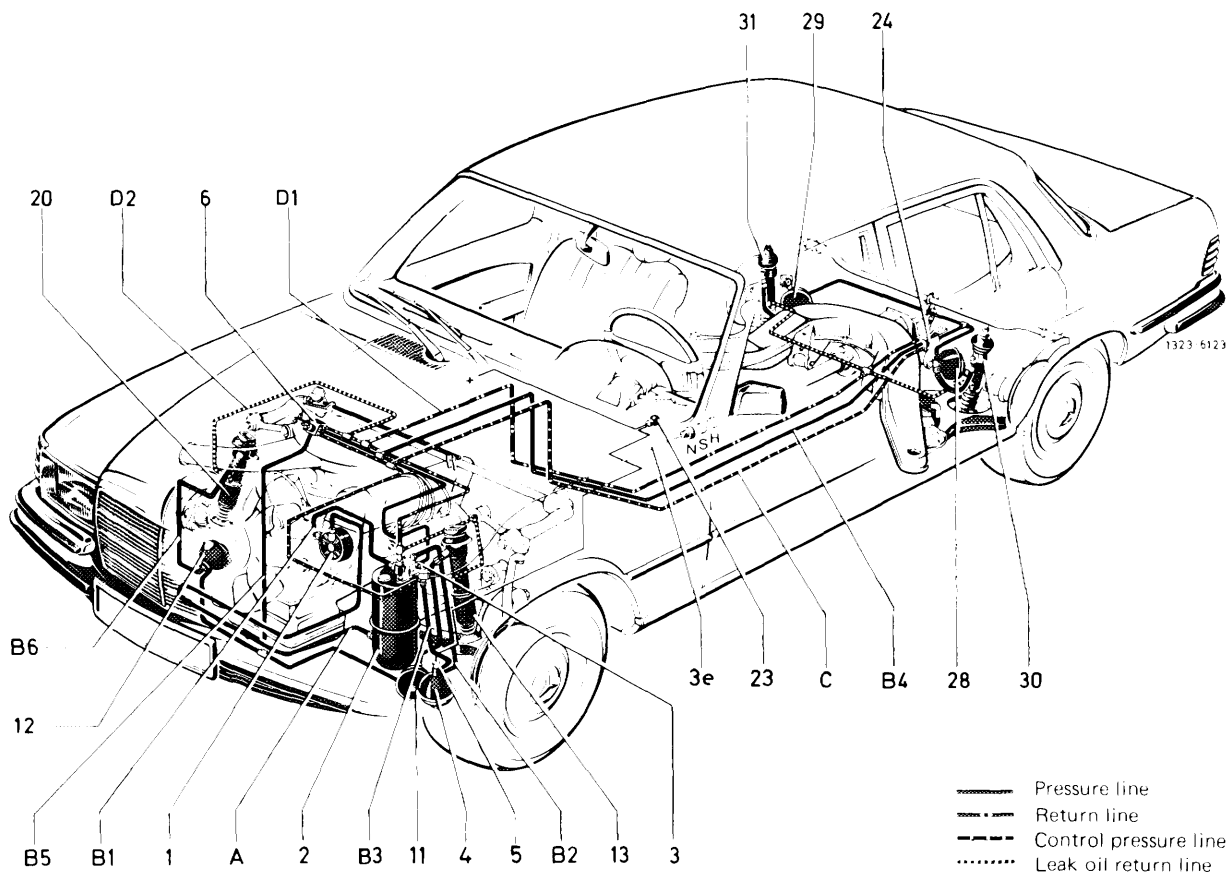

Diagram of hydro-pneumatic suspension

- Visual inspection

Pressure oil pump (1)

Oil supply tank (2)

Central reservoir (4)

Valve unit (3)

Pressure reservoir (11, 12, 28, 29)

Level controller (6, 24)

Tube shocks (13, 20, 30, 31)

Line connections.

Check hose and pipelines for leaks with the engine running, as well as for chafing marks, dents, cracks and corrosion.